

EIGHTEENTH EUROPEAN ROTORCRAFT FORUM

D - 04  
Paper N°120

CONDOR 2

THE NIGHT VISION CAPABILITY OF THE TIGER HELICOPTER

O. PRAT  
Société Anonyme de Télécommunications  
Division Optronique et Défense

September 15-18, 1992  
Avignon, FRANCE

ASSOCIATION AERONAUTIQUE ET ASTRONAUTIQUE DE FRANCE

120-1

## 1 - INTRODUCTION

CONDOR 2 is the thermal camera of the pilot's visionics system integrated into the PAH2/HAC (TIGER) French/German helicopter. This system allows the helicopter to perform low-altitude flight at night or in poor weather conditions.

This thermal camera is being developed in parallel with the Condor 1 programme (thermal imager of the TRIGAT Long Range sight of the TIGER helicopter). Most of the Condor 2 modules are common with Condor 1 : IRCCD detector, imager (focussing optics and temperature reference source), scanner , video electronics, cooling machine and the complete electronics box (TIE).

Modules being developed specifically for Condor 2 include the Thermal Imager structure and housing, front part of the optics (telescope, elevation mirror and window) and part of control and tests software.

The main specific requirements for a piloting thermal imager are :

- a wide field of view,
- a magnification equal to 1,
- large angular movements of the line of sight,
- a very good thermal sensitivity to detect reduced contrast objects in the landscape,
- high reliability to ensure the safety of the mission.

## 2 - INTEGRATION IN THE HELICOPTER (figures 1,2,3)

CONDOR 2 consists of two line replacable units : the Thermal Imager (TI) and the Thermal Imager Electronics (TIE).

The TI is mounted on a platform made by MBB in the helicopter nose. The TIE is located in the helicopter hold. These three subassemblies form the Pilot Sight Unit (PSU).

The PSU is linked to two helmet mounted sight/displays (HMS/D), one for the pilot , one for the gunner of the helicopter. These three subassemblies form the Pilot Visionics System (PVS).

The thermal video is displayed in the HMS/D of the pilot and of the gunner of the helicopter. The line of sight is slaved to the position of one of the two helmets or to a joystick speed. In case of conflict priority is given to the pilot.

Elevation movement is performed inside the thermal imager. Azimuth movement is performed by the platform.

To ensure maximum safety and reliability, following have been foreseen: in case of failure of the HMS/D or of the data link between the HMS/D and PSU, the PSU is placed in a fixed forward position and the image is displayed on a head down display; in case of failure of the PSU the image of the Condor 1 thermal imager large field of view can be displayed in the HMS/D.

### 3 - PRINCIPLE OF OPERATION

The TI (figure 4) includes the optics, the detector module, a closed cycle cooling machine, part of the video processing and a DC/DC. The TI is a hermetically sealed unit.

The TIE (figure 5) is configured as a 9 MCU unit to the ARINC 600 standard. It may be placed 10 meters away from the TI. It contains the remainder of the electronics providing overall control and additional image processing.

It is configured as a set of replaceable modules giving efficient maintenance and allowing reconfiguration for other applications. Provision is also made for the future incorporation of additional image processing.

#### Optical chain (figure 6)

A focused image on the detector array is obtained by means of an optical chain comprising :

- an entrance window which has a deicing capability,

- an elevation mirror which provides deflection of the line of sight in elevation,
- an afocal telescope,
- a scanner module operating in parallel beam incorporating a high precision scan position sensor. Signals generated by this device are triggering the video acquisition.

The scanner also performs the interlace

- a focussing module known as the imager which contains temperature reference device (Peltier element) and aperture stop.

The temperature reference source is focused onto the detector during the dead scanning time. The relevant detector signal is used for gain and offset correction.

The total field of view of the optical chain is  $40^\circ$  in azimuth by  $30^\circ$  in elevation. Evolution to  $70^\circ$  by  $30^\circ$  is achievable.

The optical chain is passively athermalized.

#### IRCCD detector and cooling machine (figures 7 and 8)

The IRCCD detector uses a CMT detector array hybridized onto a silicon CCD chip, both located in a cryostat and cooled to 77K.

Aside from the detector elements it contains significant signal preprocessing onto the CCD chip to minimize the number of electrical lead-through at the dewar.

The first plane contains 288 lines with 4 P.V. elements made in a monolithic structure.

The second plane contains monolithic CCD circuits which integrate the charge of the 4 elements, perform AC coupling and move the charges to the CCD multiplexers arranged on the same plane. Analog video is transmitted from the dewar through 16 lines. Rest of the connection is used for the clock and control signal of the IRCCD detector.

The 2 planes are connected each other by indium bumps technology.

The cooler is a closed cycle cooling machine (1W.). The cold finger in the detector dewar is connected with the compressor with an approximately 30 cm long gaz pipe.

The cooler contains an electronic control circuit which in combination with the temperature sensor in the dewar makes it possible to keep the detector temperature constant at a fixed value.

### Video generation (figures 9 and 10)

After video signal generation by the IRCCD chip, a number of analogue processes are carried out : sample and hold, multiplexing and analog to digital conversion on 12 bits.

Video processing of the digital IR signals includes :

- gain and offset correction to remove various detector artefacts,
- resenquencing to provide a data stream in the numerical order 1 to 288,
- buffering for transmission to the TIE,
- phase delay compensation of the staggered geometry of the detector array,
- automatical or manual control of gain and offset. The task of this function shall not be confused with the correction of offset and gain of the detector. For the control of the video amplification and DC level, evenly distributed samples are taken from the visual field and stored. After an analysis, a compression factor is calculated and used to adjust the video signal to the storage possibilities of the frame store and to the dynamic range of the display monitors. This includes a reduction of the dynamic range down to 8 bits,
- TV serial format conversion by means of a frame store memory,
- digital filtering to enhance the edges of the picture,
- D/A conversion. Two analogue video signals in conformity with STANAG 3350 Class B are transmitted to the helmet mounted displays for pilot and gunner.

Digital video (12 bits) is also available at the output of the TIE for futur additionnal processing (e.g. sensor data fusion)

Considerable use is made of ASIC and other miniaturisation techniques to enable these functions to be provided in acceptable volume with an acceptable power consumption.

### Control and Interfaces

The Condor 2 TIE is linked to the azimuth platform, pilot helmet mounted display (HMS/D) and gunner helmet mounted display (HMS/D) via RS 422 asynchronous links.

The master HMS/D transmits various control signals to Condor 2: angular commands for the line of sight (elevation for TI, azimuth for the platform), mode of operation...

Angular commands are dispatched by the TIE to the TI and the platform. These send back actual positions to the TIE which transmits then to both HMS/D.

Detailed status information is sent in the same way to provide in flight and maintenance data.

#### Condor 2 summary of characteristics

* optical and photometric	
spectral bandwidth	8-12 m
field of view	40° by 30°
elevation range	- 45° to +20°
detector	IRCCD
NETP	some hundredths of degree
*mechanical	
TI weight	18 kg
TIE weight	11 kg
*electrical	
power	210 W from 28V. on board power supply
video	conform to STANAG 3350 class B
*Thermal	
cool downn time	< 8 minutes

#### 4 - PROGRAMME

The CONDOR 2 thermal imager has now been in full scale development under contract of MBB (Abwehr und Schutz) in the frame of EUROMEP for EUROCOPTER.

The system is being developed under responsibility of SAT in cooperation with ELTRO GmbH.

The programme calls for the production of number of prototypes of progressively A, B and C model standard to enable the customer to undertake the system integration and tests programme on the helicopter.

Prototypes of A standard have already been delivered to the customer.

Prequalification programme of B standard prototype is scheduled end of 1992.

Serial production is scheduled during the second half of the nineties.

## 5 - CONCLUSION

This paper has described the principle of operation and techniques which are being used to produce a piloting thermal imager based on the use of IRCCD detectors.

The tests on the first prototypes are very encouraging and show up that most of the requirements (including thermal sensitivity) are fulfilled.

Investigations can be undertaken on possible evolutions of the CONDOR 2 thermal imager such as enlarged field of view and elevation range, additional image processing, smaller volume...

## 6 - ACKNOWLEDGEMENTS

The work described in this paper has been supported by the ministry of defence of France and Federal Republic of Germany.

figure 1 - TI

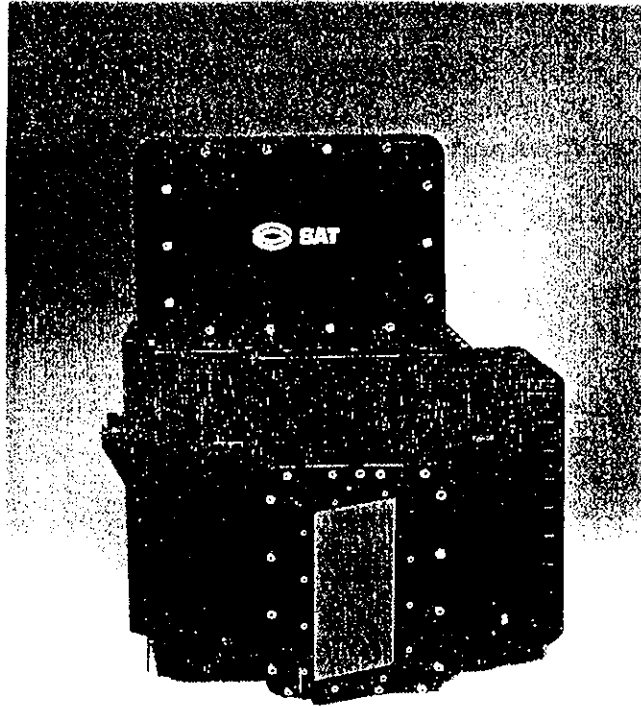

figure 2 - TIE

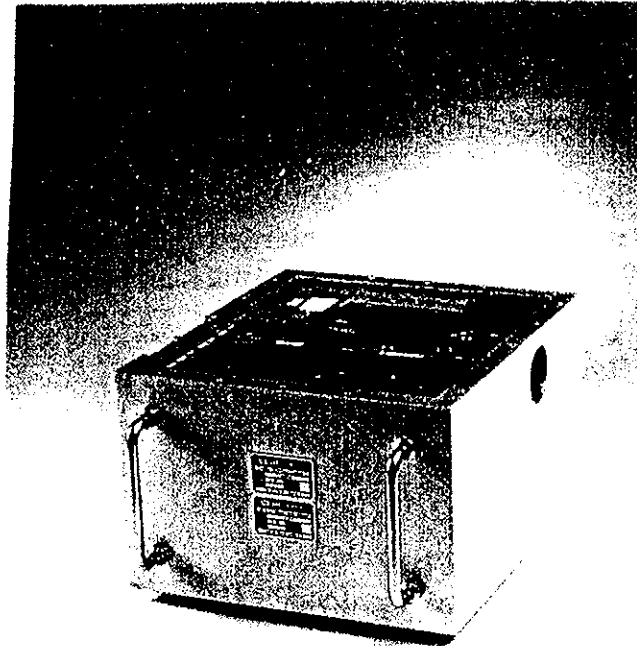



Figure 3 - PSV Overview

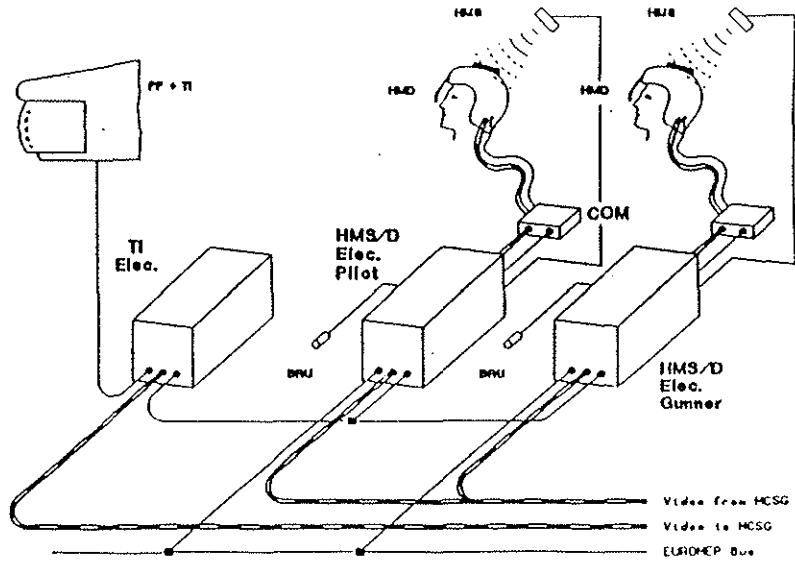

figure 4  
TI BLOCK DIAGRAM

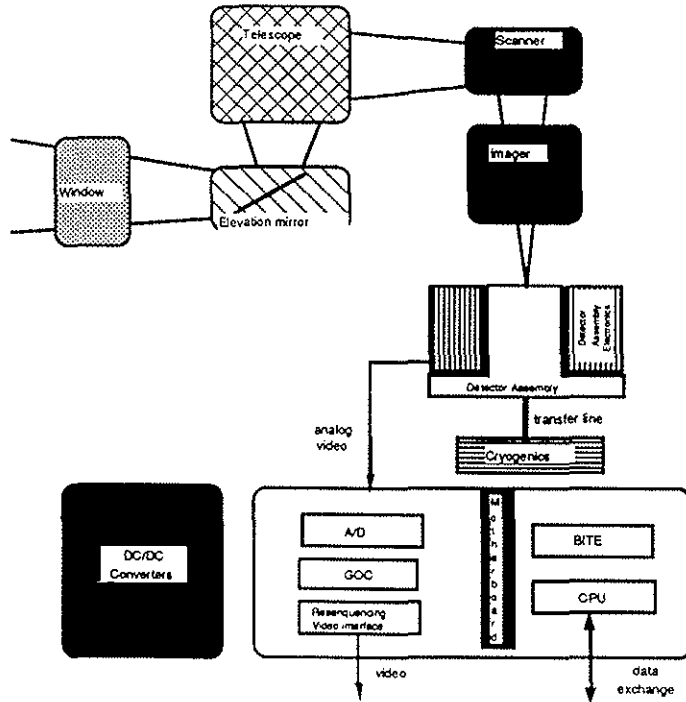

Figure 5  
TIE BLOCK DIAGRAM

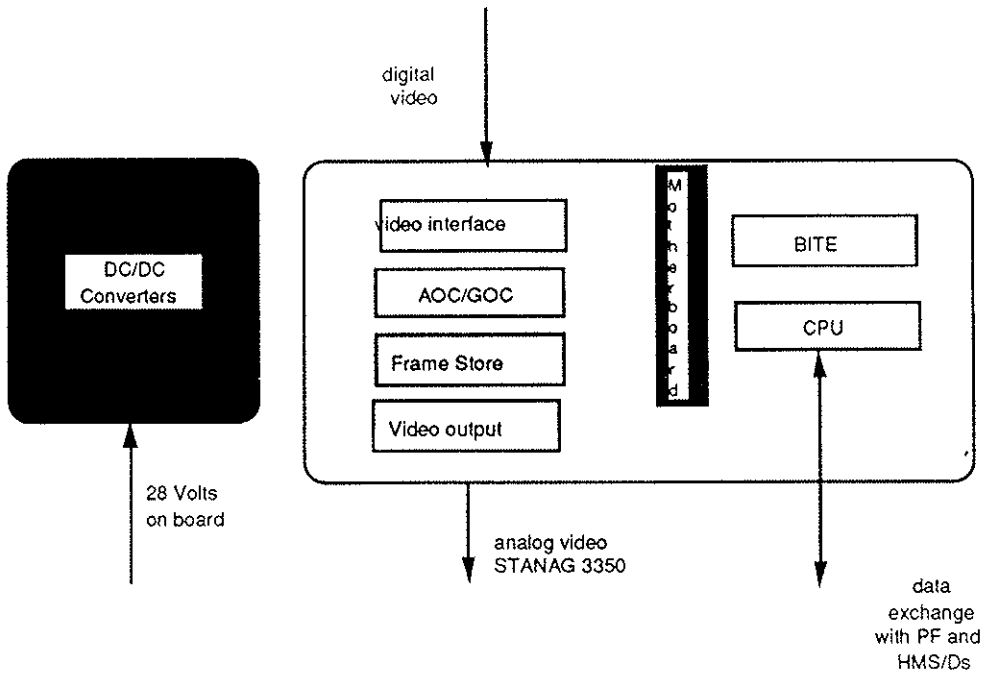

Figure 6  
CONDOR 2 OPTICAL CHAIN

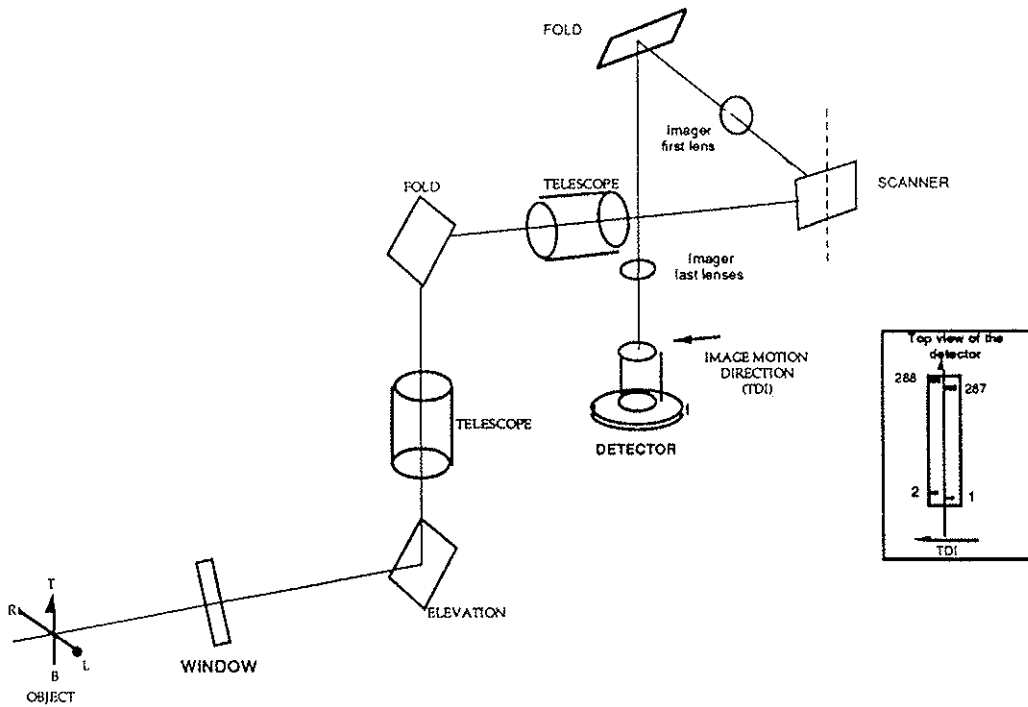

Figure 7  
Detector Array

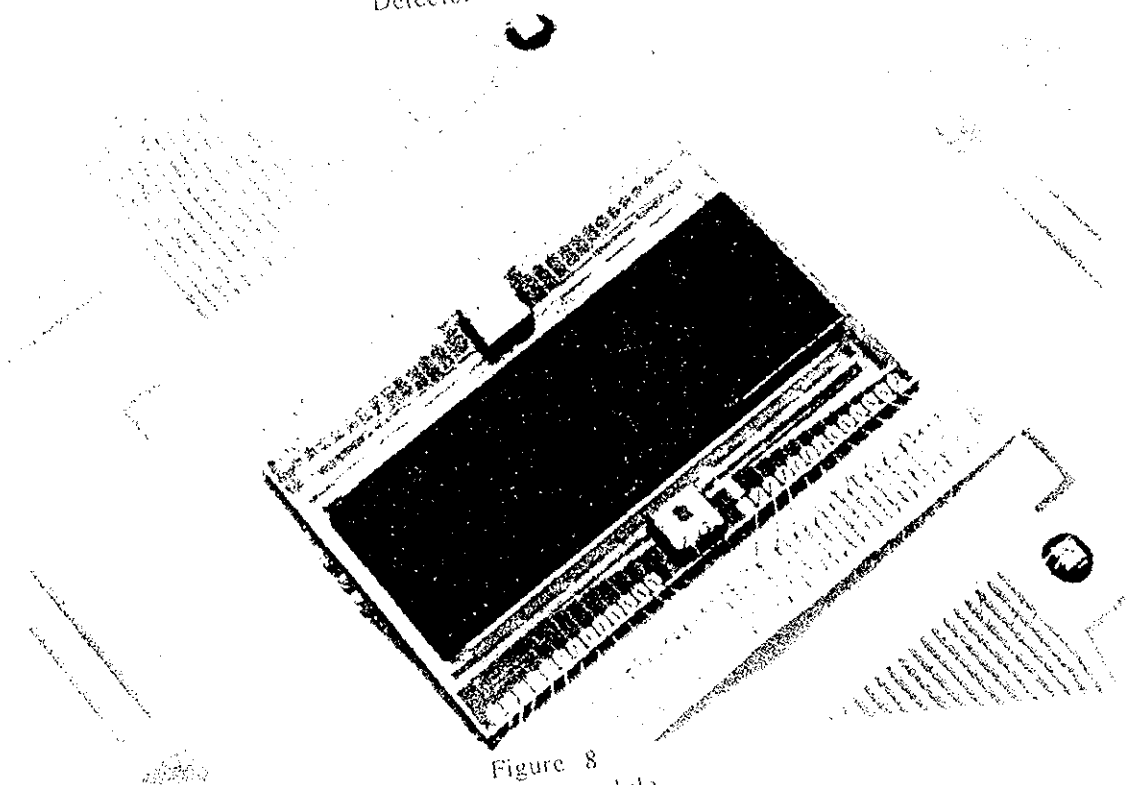

Figure 8  
Detection module

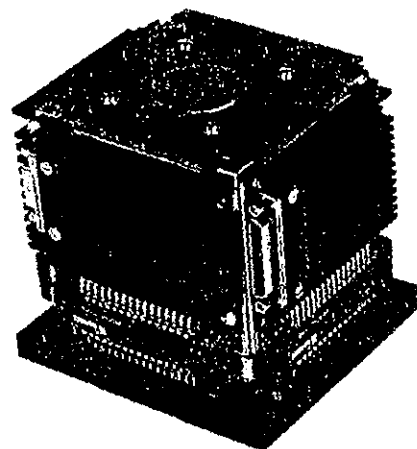

Figure 9

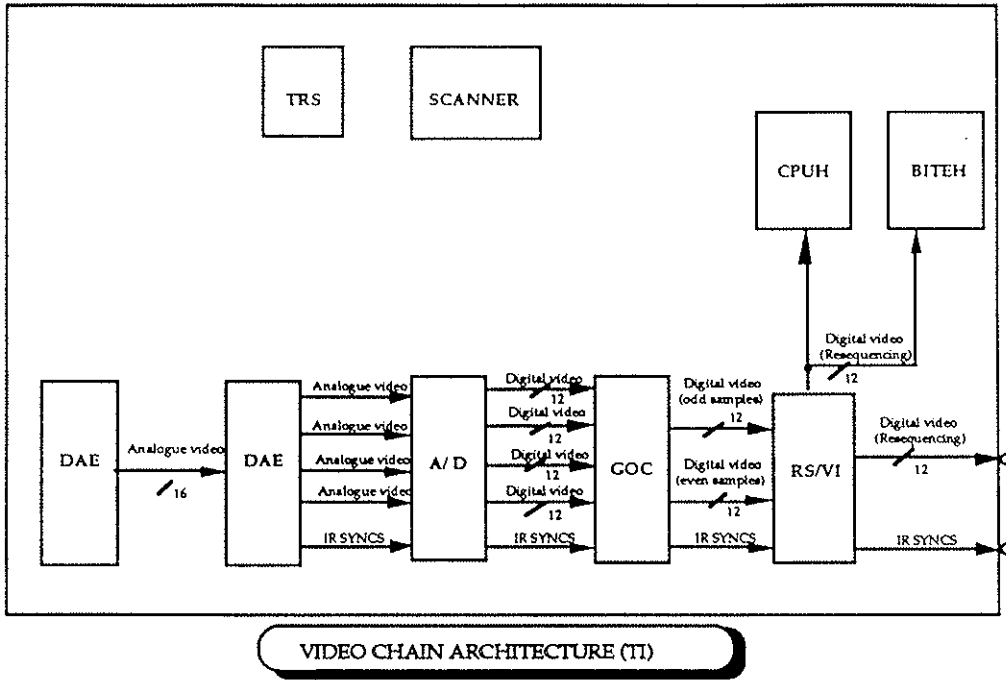

Figure 10

