

**EIGHTEENTH EUROPEAN ROTORCRAFT FORUM**

SP - 06

**Paper N°506**

**"WILL ROTOR HUBS LOSE THEIR BEARINGS ?"  
A SURVEY OF BEARINGLESS MAIN ROTOR DEVELOPMENT**

Helmut Huber  
Eurocopter Deutschland GmbH  
Munich, Germany

September 15-18, 1992  
Avignon, France

**ASSOCIATION AERONAUTIQUE ET ASTRONAUTIQUE DE FRANCE**



# "WILL ROTOR HUBS LOSE THEIR BEARINGS?"

## A SURVEY OF BEARINGLESS MAIN ROTOR DEVELOPEMENT

Helmut Huber  
Eurocopter Deutschland GmbH  
Munich, Germany

### Abstract

Main rotor systems have since long been the subject of intensive research and development work in the helicopter industry. This is due to the fact that, historically, rotor heads have always been the most complex helicopter components, difficult to maintain and costly to operate. Advances in composite materials have made it feasible to develop new rotor concepts during the past 25 years, which totally eliminate the system of hinges and bearings - the bearingless-rotor design.

A review of the developments in BMR-technology is presented. The paper includes a history of the BMR concepts that have been developed and flown by the different manufacturers over the past 20 years. The critical aspects of bearingless-hub design are summarized; they include the design of the flexbeam and pitch-control structure, the possibilities of providing inplane-damping through various couplings and emphasizes design aspects of elastomeric materials damping devices. Representative results of recent designs are presented to illuminate the achievements made. Finally, an outlook into possible future trends in BMR-technology is given.

### Introduction

Helicopter main rotors are commonly recognised as the more complex components which make up for the general complexity of this type of air vehicle. Indeed, the design of a main rotor is not a simple task and conceals a number of difficult problems to guarantee proper functioning.

Having that in mind, since the birth of the helicopter, the classical constructors have always been active in looking for novel ideas - both in terms of novel concepts and for detail improvement. New designs for rotor heads have been proposed fairly regularly. In the quest for design simplicity, there were mainly two developments that practically provided the necessary conditions for the design of new rotor heads in the past 20 years. These are: (1) The development of composite materials, which, besides its light weight, have "fail-safe" features inherent to their fibrous nature, and (2) the development of viscoelastic (elastomeric) materials which can be efficiently used for the design of laminated

bearings or for high hysteresis type of elastomeric elements, which provide high levels of damping.

These technological developments have made it feasible to design and develop new rotor concepts, eliminating partly or totally the system of hinges and bearings, the Bearingless Main Rotors (BMR). These rotors aim for a complete deletion of all three hinges of a conventional rotor. Figure 1 shows a schematic of a bearingless rotor build-up. Blade motions in the flapwise and chordwise directions are accomplished through elastic bending, and blade pitch-control is achieved by elastically twisting the inboard (flexbeam) portion of the spar. The moment applied to the blade from the pushrod is transmitted through a pitch-control element, which has to be rather rigid in torsion. The main goal in such design is simplicity, because of the favourable implications for rotor system weight, cost, reliability and maintainability.

The purpose of the present paper is to provide a review of the BMR-systems designed and tested, to discuss the main aspects in the design, and the achievements made so far. Finally, some prospects for future developments in BMR technology are presented.

### Bearingless Main Rotor Developments

At one time or another, most of the companies of the helicopter industry have worked towards the development of bearingless rotors and have investigated in eliminating the blade retention/pitch change bearings from their main rotor systems.

Interestingly, the first successful efforts to apply bearingless rotor technology were made on tail rotors, during the design competition for the UTTAS-Helicopter in the early 1970's, in which both competitors used stiff-inplane bearingless designs for the tail rotors (References 1 and 2). These efforts have continued at Hughes with the AH-64A composite Flexbeam Tail Rotor (Reference 3), and with prototype tail rotors development at Aerospatiale (Reference 4), and MBB (Reference 5).

The design of a bearingless main rotor, quite obviously, remained a more difficult problem. When examining the variety of BMR baseline concepts, the manufacturers went different ways in their design approaches. The following is a brief history of the BMR concepts that have been developed and tested.

---

Presented at the Eighteenth European Rotorcraft Forum, Avignon, France, 15-18 September 1992

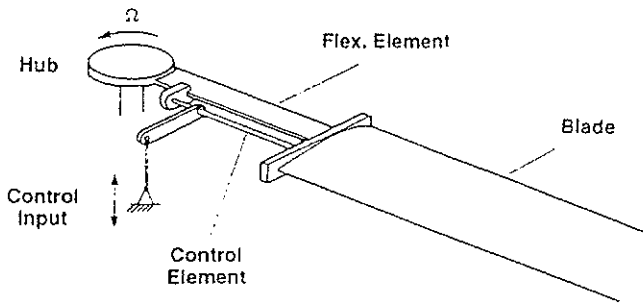

Fig. 1 Schematic of a bearingless rotor built-up

**Lockheed**

The first major effort to develop a bearingless main rotor was conducted by Lockheed, California, who developed a matched-stiffness rotor installed on the XH-51A helicopter in 1966. The rotor was four-bladed and used steel flexures at the root with polar symmetry for a matched stiffness configuration. Pitch control was by means of a steel torque rod forward of the flexbeam. The low inplane stiffness was mainly necessary to achieve the desired torsional flexibility. The rotor had negative pitch/flap and pitch/lag coupling, which was destabilizing.

The rotor underwent flight testing on a XH-51A helicopter (Figure 2). The testing was only partially successful, the aircraft showed marginal air resonance stability, and ground resonance stability was acceptable only on a smooth prepared surface. From the todays point of view, this development, was somewhat premature, due to the limited knowledge of aeromechanical stability and of the use of conventional materials at that date. Reference 6 described the development of the Lockheed BMR system.

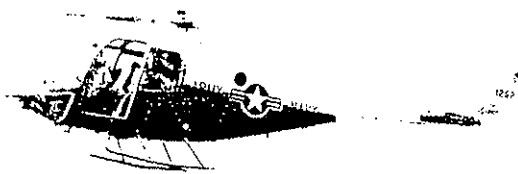

Fig. 2 Matched-stiffness rotor test aircraft XH-51A

**Boeing Vertol**

Boeing Vertol, Philadelphia, USA began the development of a Bearingless Rotor in 1978 under a US-Army Government contract. For flying qualities, the design goal was set to depart as little as possible from the characteristics of the BO 105 Hinge-

less Rotor, i.e. to match both the basic first flap frequency dynamics (1.12/rev), corresponding to an equivalent hinge-offset around 14 percent, and the first chord frequency of 0.68/rev (soft inplane design). References 7 and 8 described the development of the BMR design.

The rotor (Figure 3) consisted of two parallel fiberglass flexures with a C-channel cross section that were rigidly attached to a rotor shaft fitting. A torque rod was placed between the two C-beams, at the center of twist. The flexbeam used 12.5 degrees prepitch to introduce structural flap/lag coupling, and 2.5 degrees negative droop to improve stability. At the outboard end of the beam, the blades were attached to individual blade-to-beam joints. The rotor had no sort of elastomeric or other type of damping device.

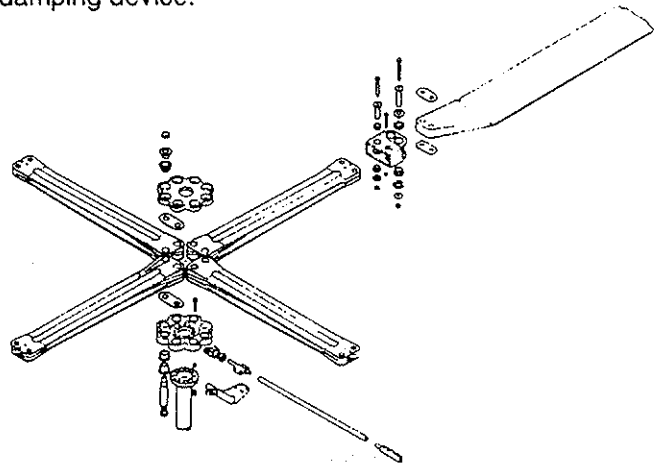

Fig. 3 Boeing Vertol bearingless rotor

The Boeing BMR first flew in 1978 on a BO 105 test vehicle (Figure 4). Initial flight tests indicated that ground resonance damping was inadequate, which was cured by stiffening the landing gear. It had similar air resonance characteristics to the Baseline BO 105 rotor, except at lower collective pitch settings. The original Boeing BMR was subsequently tested in the NASA Ames Wind tunnel, where some elastomeric damping material was bonded to the beams. The rotor was finally destroyed in the tunnel in 1982 due to an operator's error.



Fig. 4 BO105 with BMR in flight

Boeing Vertol continued its BMR efforts under the US-Army's Integrated Technology Rotor (ITR) Programme. This activity was cancelled when Boeing teamed with Sikorsky for the LHX program.

**Aerospatiale/ECF**

Aerospatiale, France, was always investing a large part of its research and design work to finding new solutions for simplifying the basic functions of rotorheads, as summarized in Reference 9. Among the various types of heads experimented on a SA 341 "Gazelle" helicopter was also a bearingless rotor head, called Triflex. Its development began in 1972. The three-bladed, soft-inplane rotor (Figure 5) was an attempt to eliminate not only the blade retention/pitch change bearings, but also the control rod reaction bearing as well. The rotor head consisted primarily of a set of fiberglass-epoxy yarns that were imbedded in an elastomeric matrix to form a flexible arm. The elastomeric matrix served also a second role, i.e. to introduce some structural damping for the lead-lag motion. The ends of the flexible arms were rigid fiberglass attachment blocks that connected the arms to the rotorshaft and blades. These arms had torsional flexibility, while the flapping and inplane stiffness was relatively high. The rotor had a flap frequency of 1.06/rev, a lag frequency of 0.72/rev and 2.5 degrees precone.

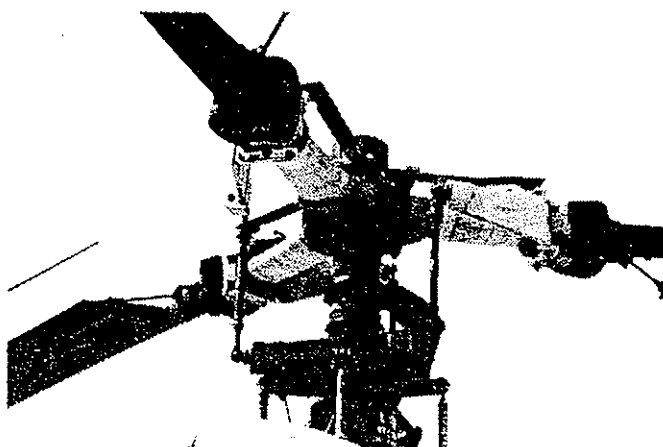
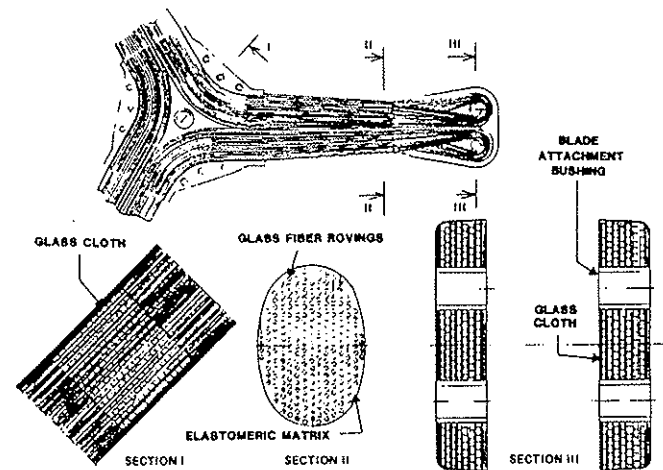

Fig. 5 Triflex hub construction



Fig. 6 SA 341 Gazelle helicopter

The flight tests of the 3-bladed Triflex rotor head were performed on a "Gazelle" (Figure 6). Apparently, most of the results were rather successful, however, the lead-lag damping was very low, resulting in a weak tendency for ground resonance instability, which was cured by installation of a hydraulic damper on the landing gear. Due to some coupling problems, also the lead-lag stresses and vibration levels were very high in certain flight conditions. The knowledge of the effect of several head and blade parameters was not yet developed at that time, and practical solutions to these problems were not found. Reference 10 reviews this development.

In further development of the Triflex rotor, Aerospatiale increased the number of blades to four, to reduce vibrations, and installed a lag damper to ensure ground resonance stability. A limited flight test was conducted. Primary development of the Triflex rotor hub configuration was completed and the conclusion was made that solutions of the various problems noted would be possible. In the following phase, Aerospatiale has shelved development of its Triflex BMR in favour of its Spheriflex elastomeric rotor (Reference 9).

**Bell**

Bell Helicopter Company, Texas, throughout the 1970's and 1980's has been experimenting on composite hubs (References 13). The four-bladed BMR, the Model 680 rotor (Figure 7), consists of a one-piece fiberglass structure that forms the flexbeams for all four blades. Each arm has a torsionally flexible feathering element outboard and a flapping flexure inboard. Pitch change is transmitted from the pitch links to the blade by torsionally stiff cuff assemblies that surround the arms of the flexbeams. The inboard portion of the cuffs are connected to elastomeric shear restraints and elastomeric lead-lag dampers. The flexbeams extend to 22 percent of rotor radius, where the beam, blade and cuff are bolted together. This rotor systems incorporates the Bell design philosophy of low flapping hinge offset (2-3 percent), including flexible mast and transmission suspension for some

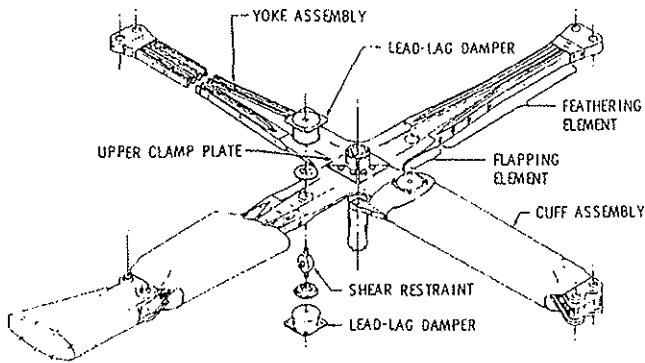

Fig. 7 Bell Model 680 rotor system

rotor flapping relief. Further design criteria were high structural lead-lag damping and uncoupled flapping, lead-lag, and pitch-change motions. Also, the flex-beam shows a highly tailored geometry for optimum stiffness and stress distributions.

The Model 680 BMR first flew in 1982 on a Model 222 helicopter (Figure 8). There were basically two problems with the Model 680 rotor: (1) The hub drag associated with the blade/cuff/flexbeam attachment was worse than expected, however, this problem could be significantly improved on the next Bell design. (2) The flapping ability of the low hinge offset flexbeam: A flapping failure mode from interlaminar shear stresses was limiting the design to only 3 degrees flapping although the design was made for 5 degrees. With 3.5 percent rotor damping available from the lag dampers alone, ground and air resonance was no problem. The biggest advantage of the rotor was the excellent vibration level, well below 0.1 g for all flight conditions, which was achieved through a linked-focused pylon and the LIVE-isolation in the vertical axis. References 11 and 12 described the Model 680 development.



Fig. 8 Model 222 with 680-BMR

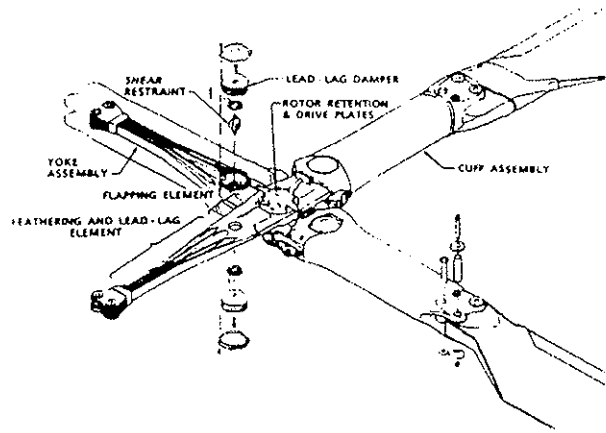

Fig. 9 4BW bearingless rotor

Having the basis of previous IR&D developments, the logical step was to apply the 680 BMR system technology to other helicopters products. Such new design is the 4-bladed Main Rotor System for the AH-1W-helicopter. The 4 BW main rotor hub (Figure 9) has now two single piece structural members, called yokes, that are bolted together at the top of the mast. Relative to the Model 680 rotor, the rotor hub drag was reduced by a cuff with elliptical cross section and fairings in the hub to blade attachment area.

Flight tests on a modified AH-1W-helicopter (Figure 10) showed very encouraging results, indicating excellent agility, low vibrations and good handling qualities. A description of the development work on this rotor system is given in Reference 14.



Fig. 10 4BW on a modified AH-1W helicopter

### Hughes/MDHC

Hughes, Tempe/Arizona, began its bearingless main rotor development late 1982, within its HARP-Program. The 4-bladed HARP-Rotor is designed as a single flexbeam type, the beam made out of Kevlar and Graphite (Figure 11). The longest portion of the flexbeam has a cruciform cross section, inboard the cruciform transmissions into two flat legs, which allow for flap motion. The flapping hinge offset is approximately 8 percent and the flex-beam extends to 23 percent rotor radius. The HARP

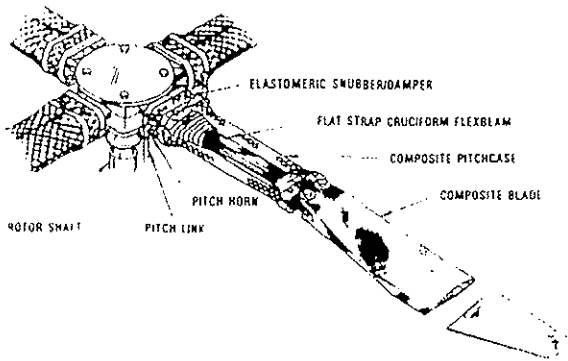

Fig. 11 HARP rotor configuration

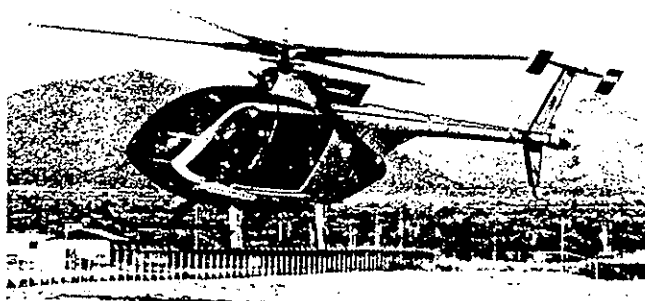

Fig. 12 HARP rotor on MDHC Model 500E

also has pitch change cuffs, consisting of a hollow graphite box, and supported in its inboard end through an elastomeric snubber/damper unit. The manual folding arrangement has two attachment joints on each arm, which adds complexity and weight.

A comprehensive flight test program was conducted in 1985, using a 500 E helicopter (Figure 12). The flight test revealed the expected results regarding rotor stability, loads, performance and vibration characteristics. A summary of the development work and the results achieved is given in References 15 and 16.

With this basis, MDHC continued with the application of the BMR technology to its new project, the MD-900 Explorer light twin commercial helicopter. The rotor basically follows the basis worked out during the HARP-Program, but is the first five-bladed BMR ever built (Figure 13). The 33.8 ft diameter rotor has a slightly lower hinge offset and a rectangular flexbeam cross section. Five blades were chosen for the rotor to minimize noise and vibration. The characteristics of the rotor were successfully demonstrated on the whirl stand and in the 40x80 tunnel at NASA Ames up to wind speeds of 200 kts. The rotor is due to fly on the MD-900 first prototype aircraft in summer 1992.

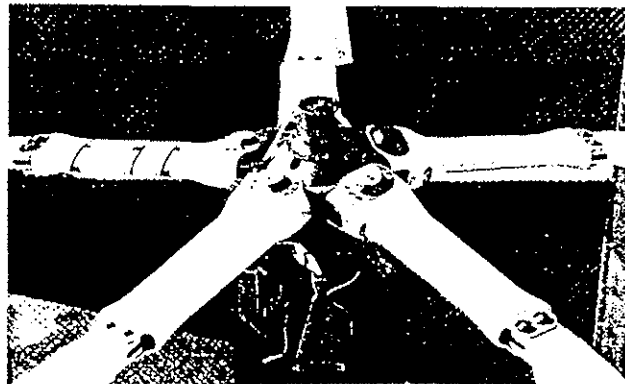

Fig. 13 MDHC five-bladed BMR for the Explorer

**Sikorsky**

Sikorsky Aircraft in Stratford, Connecticut, began the research and development of bearingless concepts on bearingless tail rotors, which are in production today on the Black Hawk and S-76.

The search for a low-offset main rotor bearingless concept have first lead to a unique stiff-inplane design, the Dynaflex (Figure 14). The Dynaflex rotor is a so-called "Gimballed" rotor system in which a stiff hub is attached to the driveshaft via an elastomeric constant-velocity joint to allow the hub to tilt and relieve the lead-lag stresses. The drive torque and flapping restraint are provided by a composite diaphragm, which transmits the torque from the shaft to the rotor, while at the same time retaining it by means of the carbon-fibre spring. Thus, the rotor provides an equivalent 5 percent hinge-offset, which is similar to articulated rotors. The gimbal concept allows to gain a substantially higher rotor tip path plane tilt over a conventional rotor (Reference 17).

The Dynaflex rotor, obviously, has the best drag of the BMR designs, but at the same time shows also a higher complexity. Sikorsky was performing many model tests with this hub concept, and completed a design of a full-scale rotor suitable for a high-speed Black-Hawk type helicopter, but never went into hardware.

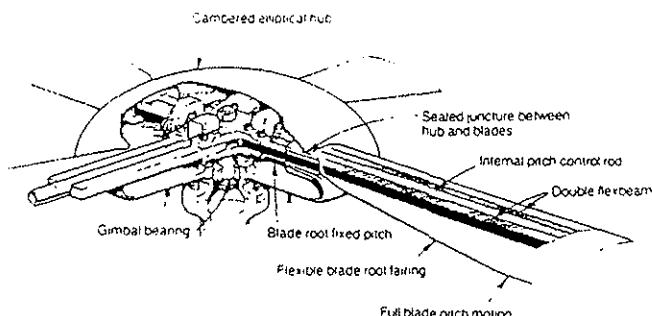

Fig. 14 Dynaflex Gimballed bearingless rotor configuration

During the LHX-Proposal phase to the US-Army, Sikorsky became responsible for the main rotor design, but did not follow the Dynaflex concept. The RAH-66 Comanche main rotor system employs a bearingless main rotor, five-bladed and 39 ft in diameter (Figure 15). Parts made using composite materials include the blade, torque tube, flexbeam, rotating swashplate, rotating scissors and quill shaft. The original design consisted of a one-piece fiberglass structure that formed the inboard flap flexures of all 5 blades and extended out to the connection bolt for the flexbeam. The hub structure was slightly changed, the PENTAFLEX rotor head being replaced by inboard blade attachments with modular fittings, that allow individual blade removal from the hub assembly for airtransportability and in case of damage. The flexbeam has rectangular cross section and inboard elastomeric damping/shear restraint elements. The equivalent flapping hinge offset lies around 9.5 percent of radius (Reference 18).

In 1991, a S-76 BMR test article, representative of the RAH-66 design concept was tested on the whirl stand (Figure 16). It is also scheduled to be tested at the NASA Ames wind tunnel facility.

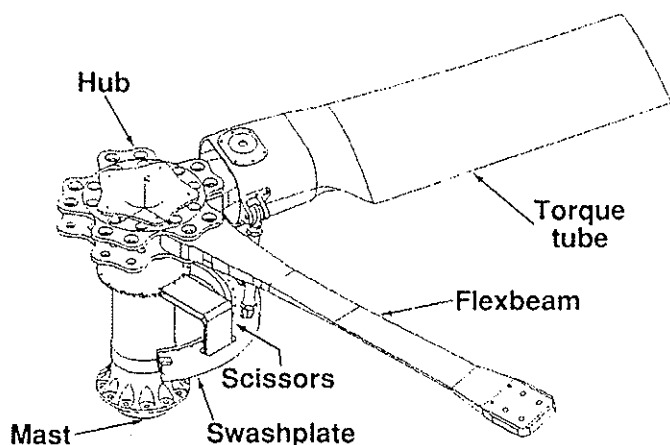

Fig. 15 RAH-66 Comanche rotor system



Fig. 16 S-76 BMR demonstrator on whirl tower

## MBB/ECD

MBB (now Eurocopter Deutschland), Ottobrunn, Germany, began its fiberglass technology development in 1961, which resulted in the successful Hingeless Rotor System. Based on this tradition, MBB began experimenting with bearingless rotors in 1981. The development was conducted in three steps: In the first concept, which was a pure research configuration, a BO 105 hingeless hub was modified to carry experimental flexbeam blades, with the original pitch change bearings fixed at a 10 degrees prepitch angle (Figure 17). Similar to the Boeing approach, the design goal was to match the BO 105 rotor system dynamics as far as possible and, hence, the flapping hinge offset was outboard at 14 percent radius. The first chord frequency was at 0.69/rev. The flexbeam had a T-shaped cross-section, and a pitch control tube was placed behind it, mounted with flexible couplings to the hub and blades. In order to provide acceptable stability, elastomeric damping strips were bonded to the flexbeam, and constrained by an outer layer of graphite epoxy laminate.

The rotor was flown on a BO 105 test helicopter in 1984 (Figure 17). Although compromised, the experimental rotor yielded basically promising flight test results; however, the rotor stability was low and the hub drag was high. The development is summarized in Reference 19.

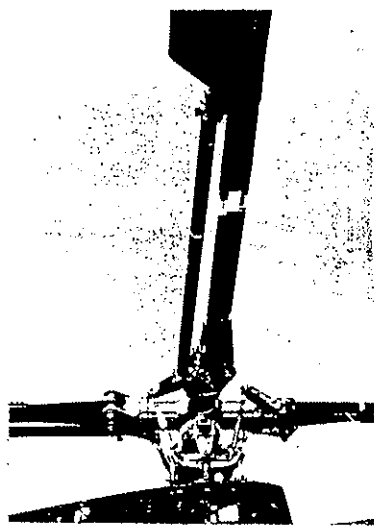

Fig. 17 MBB's FVW-Rotor experimental configuration

MBB was then developing a second prototype rotor in a more advanced design, where the stability and drag issues were particularly addressed (Figure 18). It uses a cruciform cross section flexible beam, and around this is an elliptical carbonfibre control cuff. It is made in two pieces which could be telescoped for flexbeam inspection. In this design the flapping hinge offset was reduced to about 9 percent, to provide the best compromise between agility, vibration/loads and structural integrity. The flexbeam could be shortened down by 25 percent. The rotor was tested on the whirlstand with several modifications on the hardware, to optimize the cuff



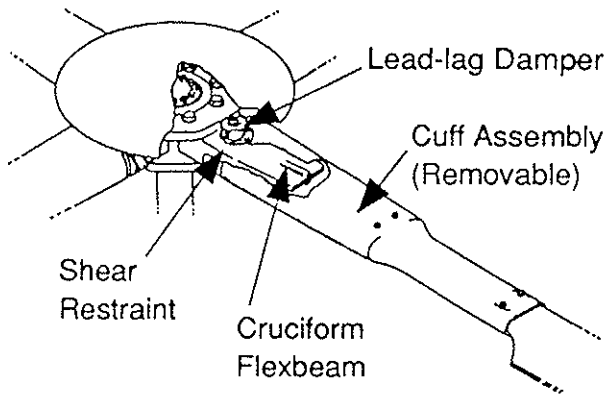

Fig. 18 BMR-P1 bearingless rotor concept



Fig. 19 Rotor installed on the BO105

design and elastomeric damper effectiveness. In 1986, the rotor was flight tested on a BO 105 with good results (Figure 19). Publications on the development of these MBB Bearingless Rotors are listed as References 20 to 22.

The results achieved during these campaigns provided a good foundation for the final BMR design for the new BO 108 helicopter. The configuration in principle follows the concept tested in the phase before, but was very much refined in the details (Figure 20). The cruciform beam shows a flatplate cross section inboard, which places the flapping hinge offset at 9 percent of radius. The carbonfibre cuff is directly bonded to the inner end of the blades' airfoil section, which results in an exceptionally smooth surface from the hub out to the aerodynamic blade part. Such a design and the inboard attachment of the beam have obvious benefits in reducing the rotor hub drag.

The total development, i.e. the flexbeam and torque tube sizing and the introduction of coupling effects was an intensive, interactive approach, which finally resulted in very satisfactory damping characteristics. Through 9 percent hinge offset, the rotor shows a proper balance of inherent dynamic stability and high maneuverability, and very low

loads and vibration levels. The rotor first flew in October 1988 on the BO 108 Prototype aircraft (Figure 21), with excellent results in aeromechanical stability, handling qualities, loads and vibration, as described in Reference 23.

Besides the BMR, ECD is developing its FEL-fibre elastomeric rotor for the Franco-German PAH-2 and the Indian ALH. This rotor follows the hingeless concept and comprises a stiff composite hub and flexible blades; pitch change is achieved through elastomeric bearings.

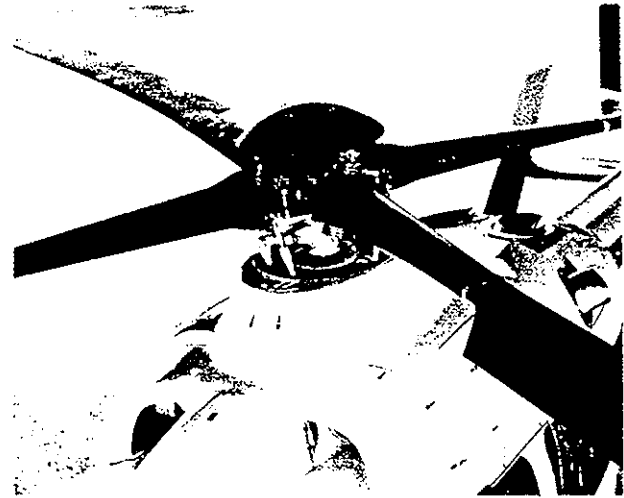

Fig. 20 BMR refined configuration

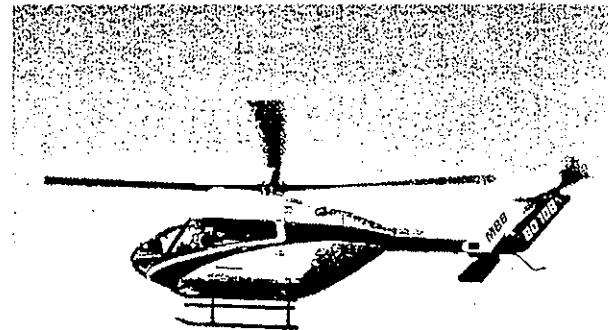

Fig. 21 BO108 with BMR during first flight

### Westland Helicopters

Westland, Yeovil, England has been studying BMR's since 1980. Design feasibility studies and analytical work were performed, mainly concentrating on the assessment of ground and air resonance stability margins of such rotors in combination with existing and projected airframe configurations. To support the work, ground and air resonance tests of a four-bladed model rotor were performed. Reference 24 is a review of the analytical and experimental studies.

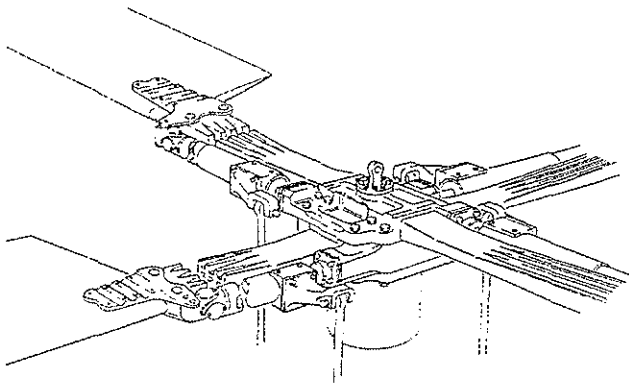

Fig. 22 Westland bearingless rotor design

In order to provide the "hard data", Westland, under a demonstrator contract of the UK-MoD, started design and manufacturing of a BMR flexure, sized for the Lynx helicopter. The rotor design, which emerged, comprised two double-ended composite glass/epoxy flexures housed in a titanium hub assembly (Figure 22). Blade pitch control is provided by a parallel torque tube, which houses an elastomeric lead-lag damper. Four full-sized flexure mouldings were produced and fatigue testing of the flexure is underway. The hardware is shown in Figure 23.

**ITR/FRR - Project**

In the mid-1970s, the U.S. Army Research and Technology Laboratories and NASA Ames Research Center have joined into a program to develop an Integrated Technology Rotor/Flight Research Rotor (ITR/FRR). The objective of the ITR/FRR program was to make significant advances over a broad spectrum of technologies. In the concept-definition studies a variety of hub concepts were proposed by the five US-Helicopter

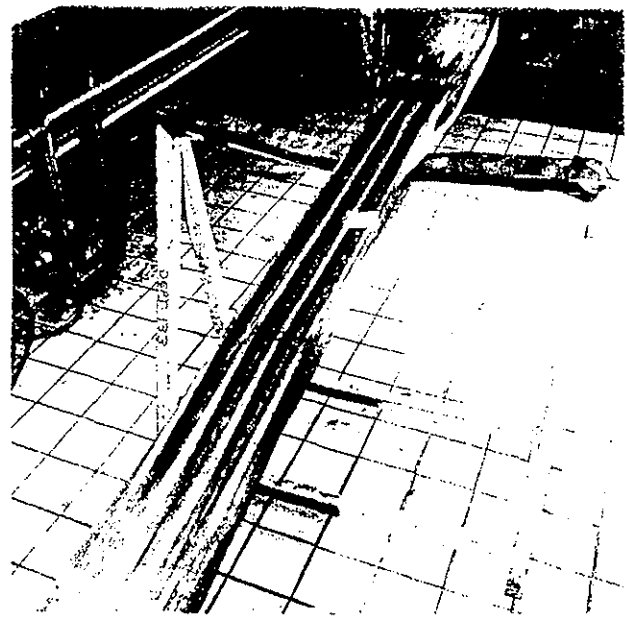

Fig. 23 Full-sized flexure hardware

manufacturers. Their description is given in References 25 to 29. Thirty-three hub-concepts were proposed, amongst them were 21 bearingless designs. Although no real design and development work was performed within this program, many of advanced design issues for new rotor hubs were examined, particularly with respect to bearingless rotor designs. The studies have also been very useful in identifying areas of weakness in the design methods. Reference 30 is a comprehensive analysis and a useful review of the concept-definition studies of the ITR/FRR-Program.

A summary and data comparison of the various bearingless hub concepts developed is given in Table 1.

Company	Type	Diameter (m)	No of Blades	Flap Hinge Offset (%)	Lag Frequency (1/rev)	Hub Precone (deg)	Control Device	Lead-Lag Damping Device	Beam Cross Section	Hub/Beam Attachment	Flown/ Tested in
Lockheed		10.70	4		0.65		Tube	No	Steel-Flex.	Bolted	1966
AS/ECF	Triflex	10.4	3	8.5	0.72	2.5	Horn	Elast/Emb	Elliptical	one Piece	1976
Bell	Model 680	12.8	4	4 (2.5)			Cuff	Elastomeric	Triple-H	one Piece	1982
	4BW	14.4	4	4 (2.5)			Cuff	Elastomeric	Triple-H	2 Pieces	1989
Boeing Vertol	BMR	9.82	4	14	0.74	0	Tube	No	Double-C	Bolted	1978
Sikorsky	Dynaflex	Model	4	5 (Gimbal)	Stiff		Tube	No	Double-C	Bolted	(Model)
	S76-Demo	13.4	5	9.5	0.7	2.5	Cuff	Elastomeric	Rectangular	Bolted	1991
MBB/ECD	FVW-Exp.	9.82	4	13.6	0.69	0	Tube	Elastomeric	T-Shape	Bolted	1984
	BMR-P1	10.0	4	9	0.75	0	Cuff	Elastomeric	Cruciform	Bolted	1986
	BMR-BO108	10.0	4	9	0.70	0	Cuff	Elastomeric	Cruciform	Bolted	1988
MDHC	HARP	8.5	4	8	0.6	2.5	Cuff	Elastomeric	Flat-X	Bolted	1985
	MD900	10.34	5				Cuff	Elastomeric	Rectangular	Bolted	1992
WHL	Exp.		4				Tube	Elastomeric	Triple-H	2 Pieces	(Model)

Table 1 Comparison of bearingless main rotor design concepts

## Main Design Considerations

In order to better understand the problems related to a bearingless-hub design, it is helpful to review briefly the important design attributes and to summarize the present state of understanding.

### Hub-Moment Stiffness:

A primary parameter in designing any type of rotor system is the fundamental flap stiffness, expressed also as hub-moment stiffness, or equivalent flap hinge offset. Usually, a low hub-moment stiffness is desired to improve vibratory characteristics, gust response and some aspects of flight stability. Conversely, a moderate or high hub-moment stiffness is desired to improve maneuverability, agility and fatigue life. These very basic design considerations have been addressed very systematically in the 1960's, early 1970's, when the development of the Hingeless Rotorcraft began (References 31, 32 for example). There are many literatures available; useful surveys are given in Reference 33 and 34.

When examining the variety of hub concepts and classifying them under the aspect of hub-moment stiffness (or flap hinge-offset), there were basically two categories which characterized the two ends of the full spectrum of rotor concepts, the conventional flap hinge (articulated) designs and the newer hingeless rotor designs. In terms of the flap-hinge offset, the first category, quite obviously, is limited to values below - say 5 percent. On the other side, the newer hingeless hubs show a trend towards relatively high values of flap-hinge offset, due to the fact, that the flap and lag "hinges" were no real hinges, but were realized through blade flexibilities, which lie more outboard. These concepts are characterized by flap-hinge offsets in the order of 11 to 15 percent of radius.

When looking on the current bearingless category, the design concept obviously allows for shifting the effective flap hinge more inboard, mainly due to the simple hub/flexbeam attachment, which is also desirable in order to minimize weight and hub drag. To further illustrate this trend, flap-hinge offsets are shown in Figure 24, where the values of the BMR developments during the last 15 years are plotted against a time axis (year of first flight). It does appear that there is a trend to be observed: With the exception of the pure experimental designs of BV and MBB, the more recent designs of ECD, MD and Sikorsky show hinge-offset values between 8,5 to 10 percent of radius. The Bell concepts show values in the lower range of 2,5...4 percent, which reflects its particular design philosophy of low hinge-offsets.

### In-plane Stiffness:

The principal design considerations with respect to the fundamental in-plane natural frequency are very well known from many literatures (Reference

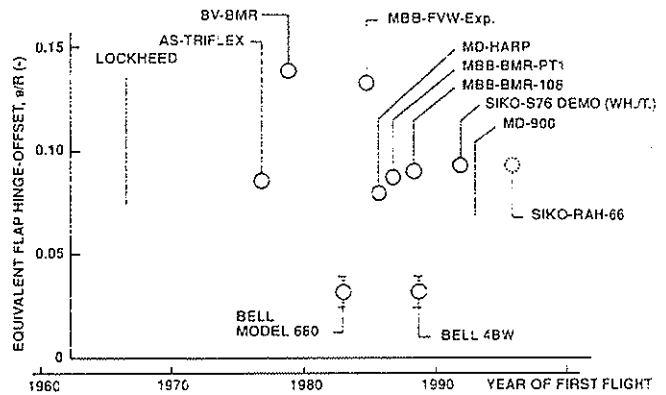

Fig. 24 Trends in BMR rotor stiffness

34). From the 10 BMR hub concepts developed and tested so far, all designs were of the soft-inplane type, with frequencies ranging from 0.6/rev to 0.75/rev (see Table 1). The soft-inplane designs give more design freedom for tailoring the flexbeam cross section, the critical chordwise loadings are low and the small dimensions of the flexbeams is a prerequisite for designing a beam with low torsional rigidity. Furthermore, the technical goals for reducing the hub weight and drag require that BMR designs be as light and compact as possible.

The critical loading conditions and the aeromechanical stability requirements for soft-inplane BMR designs were in principle known, from the substantial work that had been done on the past designs of soft-in-plane hingeless rotors (Reference 34).

### Flexbeam Design

The key element of a bearingless rotor is the inboard portion of the spar, commonly called the "flexbeam". This part connects the blade to the mast and has to carry all the primary flight loads. It accommodates the elastic blade motions in flap- and chordwise directions and the elastic twist deformation for pitch control. By proper stiffness tailoring of the beam along its length, it is possible to separate the individual functions of the flexbeam. Figure 25 shows a typical flexbeam design with the different sections tailored to their specific function.

### Torsional Stiffness:

The primary criterion in the flexbeam design is the torsional stiffness and strength, since the control requires to twist the beam collectively and cyclically. The shear stresses mainly depend on the achieved torsional rigidity.

In the early stages of its BMR-program, Boeing Vertol did a systematic study of several cross section shapes, like solid sections, split-tubes, I-beams and cruciforms (Reference 8). Figure 26 is a summary of the main results, and shows the tradeoff between the critical fatigue stresses under a

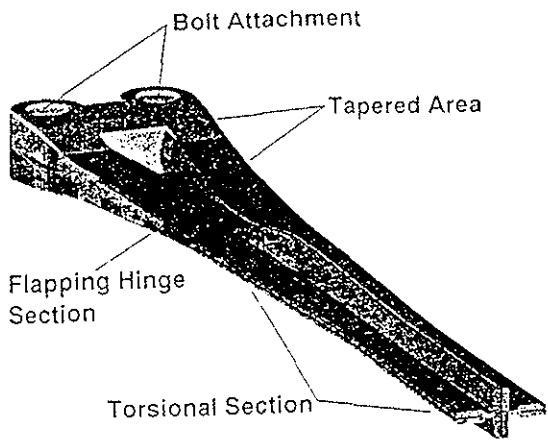

Fig. 25 Flexbeam key design areas

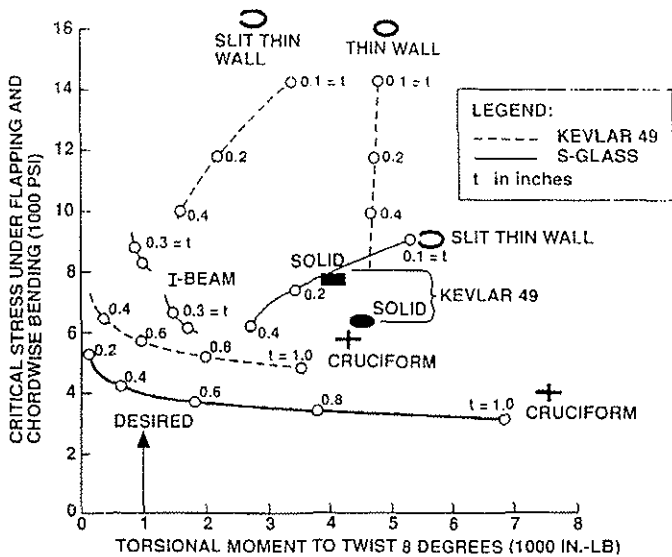

Fig. 26 Beam cross section tradeoff

given load case (alternating flap and chord moments), and the torsional moment necessary to twist the beam by a certain angle. The influence of the cross section materials is also shown.

The variety of design approaches on the present BMR designs suggests, that there is no true optimum cross section: Some of them are using highly tailored cross sections, like cruciform or Triple-H-type sections, others are using flat rectangular cross sections (Table 1). The torsional stiffness goals of all these designs can obviously be met, with careful selection of materials, tailoring of the geometry and orientation of lay-ups.

**Bending Tailoring:**

The need for inboard flapping flexibility leads usually to a design with a "hinge" section (Figure 25). The length of the hinge section is optimized for a minimum of mainly dynamic stresses caused by blade flapping. Current BMR designs usually apply  $\pm 5$  degrees of flapping angles without fatigue damage.

The radial variation of the cross section geometry is often highly tailored along the length of the flexbeam.

The design goal of such configurations is to achieve minimal dimensions, maximum flapping flexibility with reasonable endurance limits and low shear stresses. An example of a flexbeam with a nearly constant strain distribution can be seen in Figure 27. In the lead-lag direction, the flexbeam stiffness is governed by frequency requirements and by the need to tailor the bending mode shape in order to achieve maximum lead-lag damper efficiency.

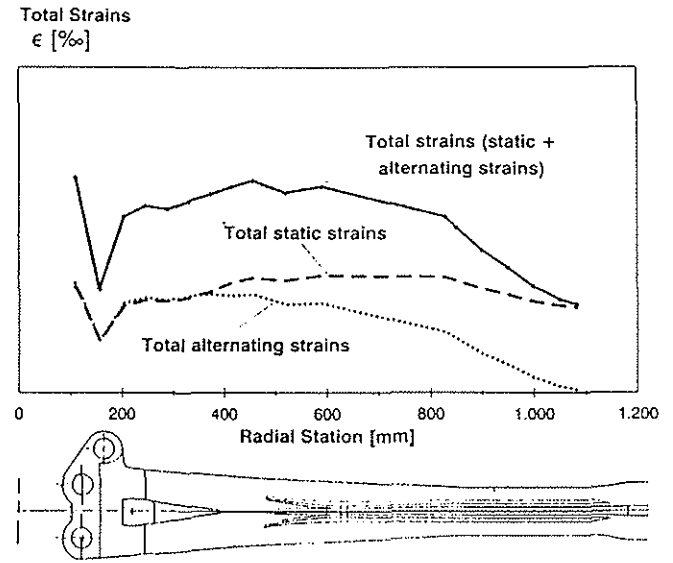

Fig. 27 Constant strain distribution

The flexbeam of the BO108 BMR uses unidirectional E-Glass/epoxy and quasi-isotropic glassfibre/epoxy fabric. Fiberglass belts are used for the attachment lugs. A flexbeam undergoing layup is shown in Figure 28.

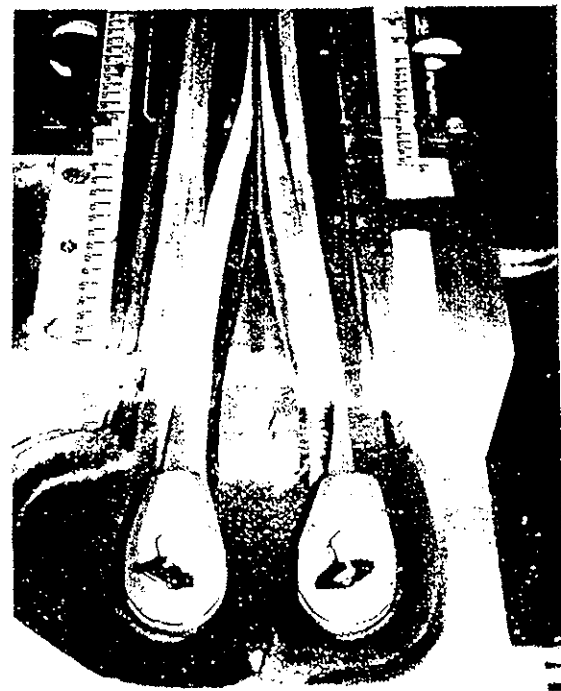

Fig. 28 Flexbeam Manufacturing

Control cuffs or pitch cases are designed to have high torsional stiffness and high chordwise stiffness to transmit the in-plane motions to the inboard damping device. Most of the current BMR designs are using primarily graphite/epoxy material in order to achieve the stiffness goals for their cuffs. Dual torsional load transfer diminishes vulnerability and increases the damage tolerance characteristics.

### Design Approaches for Damping

In general, any sort of main rotor system must be carefully designed to avoid potential aeromechanical instabilities. As is well known, for soft-in-plane rotors air and ground resonance is of primary interest. Both types of resonances are dominated by the rotor blade lead-lag motion, coupled with body motion. Whenever the regressing mode chord frequency crosses a body frequency, the potential for instability exists. To suppress these potential instabilities, some source of damping has to be introduced into the blade motions for air resonance and into the blade and/or landing gear motions for ground resonance.

The amount of mechanical damping, inherent in composite structures, typically lies in the order of 0.5 to 1 percent. Aerodynamic damping through airloads is contributing some part at 1 g thrust conditions, but has only negligible effect at zero thrust. These two sources of lead-lag damping look to be insufficient for bearingless designs. Hence, blade damping must usually be augmented by mechanical damping in the rotor system or through discrete mechanical coupling of the blade motions such that aerodynamic damping is activated.

### Pitch-Lag and Flap-Lag Coupling

Pitch-lag and structural flap-lag coupling, either separately or in combination, are known to have beneficial stabilizing effects for aeromechanical stability. However, these effects are not a general rule; each particular design must be carefully analyzed and the introduction and functioning of these types of couplings must be well understood.

The phenomenon of bending-torsion coupling on helicopter rotor blades can easily be realized by considering the blade bending behaviour (Figure 29). With the total dynamic and aerodynamic forces acting the elastic blade is deflected and, in case of a hingeless rotor, bends away from the line of the feathering axis. If the blade is bent in the flapping plane, the inplane forces create a pitching moment on the arm of the flapping deflection. Likewise, when the blade is bent in the lead-lag direction, a pitching moment on the lead-lag arm is created by the lift forces. References 35 and 36 examined pitch/lag and flap/lag coupling effects on soft-in-plane rotors stability.

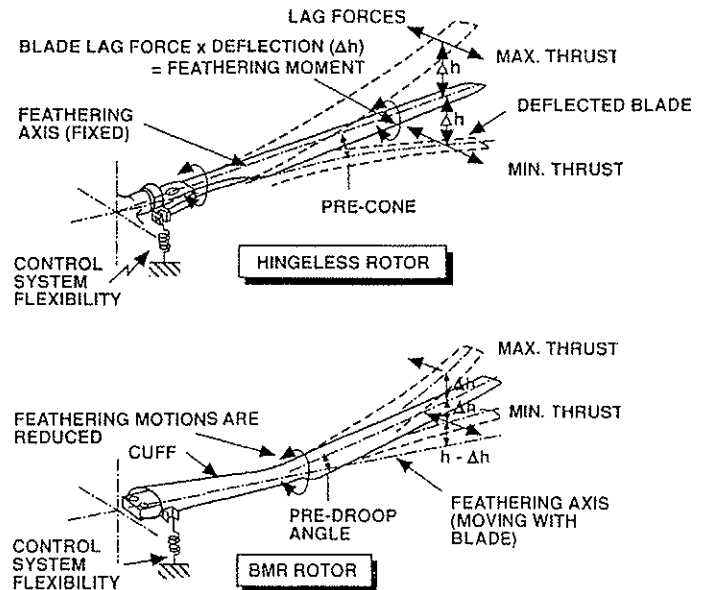

Fig. 29 Principles of lag bending-torsion coupling

When comparing a bearingless rotor with a BO 105 type hingeless concept (Figure 29) it is noticed that the inboard geometry and the sequence of the bending and feathering motions is dissimilar: The BMR does not have inboard feathering bearings and, since the effective feathering hinge for the BMR occurs outboard of the flap and lag equivalent hinges, the stabilizing coupling between the bending and feathering modes is somewhat different. Lag-torsion coupling on the BMR is reduced at low thrust due to reduction in blade-to-feathering-axis offset. Conversely, for the BO 105-rotor, minimum lag/torsion coupling occurs at around 1 g thrust collective (minimum off-axis deflection) and increases as thrust is increased or decreased.

One way of introducing beneficial pitch/lag coupling in BMR's is negative pre-droop in the portion outboard of the blade-to-beam joint. However, it must be kept in mind that blade deflections outboard of that station can partially eliminate the built-in pre-droop effect, hence, reducing the corresponding coupling. The stiffness of the control system also influences this type of mechanical coupling.

Another source of damping in bearingless rotors can be achieved through incorporation of flap-lag coupling. This coupling can principally be affected by the inclination of the principal axes of the flap and chordwise bending. This can be achieved by a pre-inclination of the flexure, as was done on the Boeing BMR. In this case, asymmetric bending of the flexure causes flap motions from chord to lag motions.

### Kinematic Coupling

An additional coupling effect can result from the specific concept of the pitch-control. The most common configuration in present BMR designs involve a control cuff to twist the blade outboard of the

flexbeam. To be effective, such a cuff has to be stiff in chordwise direction and in the cuff-to-blade attachment area, such that the lag shear loads are transmitted from the blade to the shear bearing, thus activating the elastomeric damping elements. From Figure 30 it can be seen that, when the blade moves backwards, the cuff moves forward, thus deflecting the elastomeric damping elements. Depending on the geometry of the control rod, a geometric pitch-lag coupling can be introduced, which can substantially alter the damping behaviour - both positively or negatively.

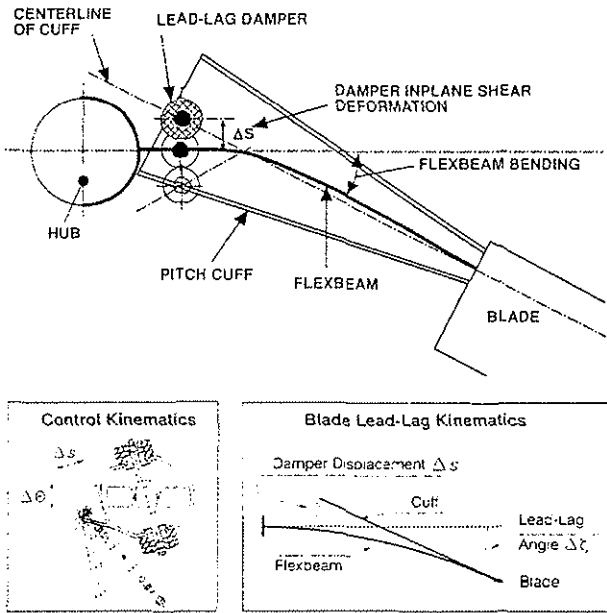

Fig. 30 Pitch/lag coupling due to blade lead-lag and control kinematics

An elementary expression of this type of pitch/lag coupling can be seen from Figure 30 (lower part), where the coupling term can be expressed by

$$\tan \delta_1 = \Delta \Theta / \Delta \zeta = \Delta \Theta / \Delta s \times \Delta s / \Delta \zeta$$

The first term in the equation is a control kinematics term, whereas the second one reflects the damper deflection or stiffness term.

As an example from an early MBB-concept, Figure 31 illustrates clearly, how in-plane damping could be improved by changing the damper stiffness and by introducing proper geometric pitch-lag coupling through a change in the inclination of the damper support axis. The combined effect was a doubling of damping over the whole collective pitch range. However, it should be noticed, that in case of a complete rotor-body-dynamics system like ground resonance, the influence of positive pitch-lag coupling on stability may change, and may even be negative in the resonance point. This has been demonstrated by analytical studies (Reference 37).

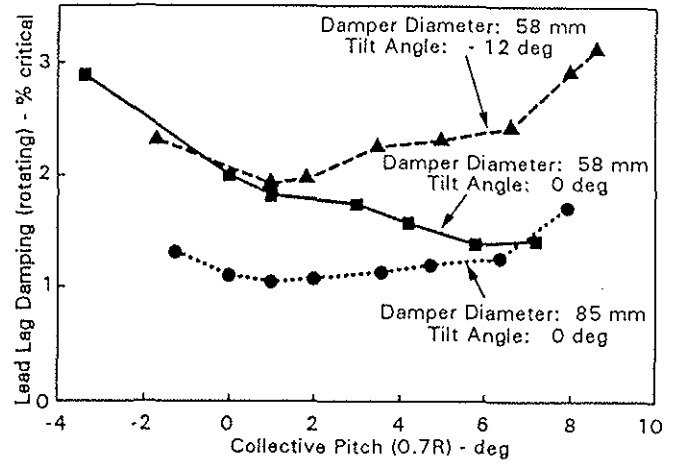

Fig. 31 Test results on coupling sensitive parameters

It is evident from these discussions, that aeroelastic coupling, on the one side, offers considerable potential for augmenting rotor damping. On the other side, stability improvements through sensitive concept parameters of this nature is a highly complex problem, which requires thorough investigation and a high level of confidence in the predictive capability of aeroelastic mathematical models.

### Elastomeric Damping

The concepts described before indicate that the most common BMR configuration today involves a combined snubber/damper element at the inboard section, to control the pitch/bending coupling and to augment structural damping. A typical arrangement is shown in Figure 32. To be effective, such elements have to be strained through the inboard motion of the torque structure, thus providing an additional damping in the order of 2 to 4 percent.

The design of such elements is rather complex task. The two main characteristics which are of considerable interest are the mechanical material non-linearities and the thermoviscoelastic characteristics. Some major influences are presented below (from Reference 38).

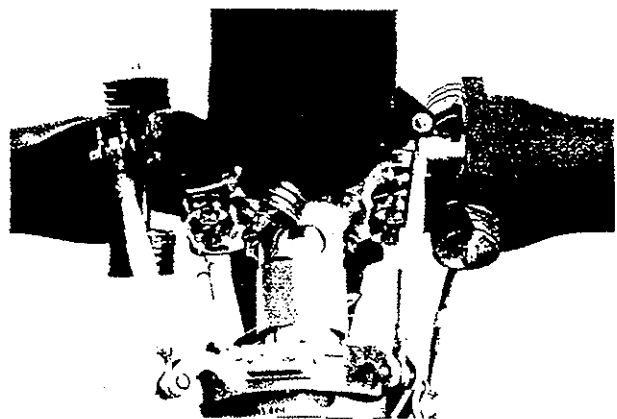

Fig. 32 Elastomeric damper elements on a BMR

**Effect of Amplitude:** First, the viscoelastic response of high damping elastomers shows a strong non-linear dependence on the shear loading deflections of the damping elements. Figure 33 shows the results of component tests conducted on one type of silicon damper (Reference 38). In the plotting of shear force vs. shear deflection, the strongly non-linear behaviour can clearly be seen: At small amplitudes a dynamic "hardening" of the material is observed, accompanied by a reduction in the loss factor. Conversely, with decreasing amplitudes a strain-softening is noticed.

The analysis of these results indicates that both the dynamic spring rate (curve slope) and the mechanical loss factor (hysteresis loop area) is a highly non-linear function of amplitude. A sufficiently high loss factor can only be achieved with a certain amount of damper displacement. For a concrete design it is essential to understand where this optimum working point is and how the whole system can be forced into working around this point.

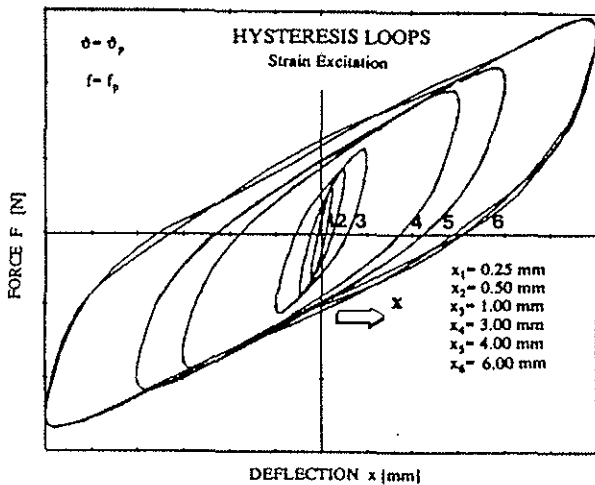
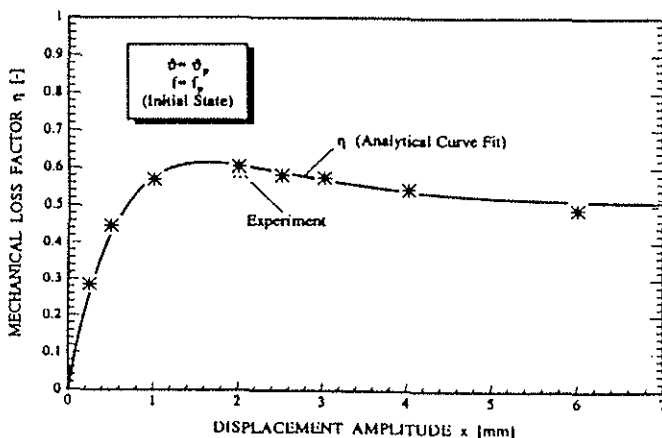

Fig. 33 Damper characteristics (complex stiffness and mechanical loss factor) as a function of displacement amplitude



**Effect of Frequency:** A second important effect on elastomeric damper characteristics is the influence of frequency. Component testing for a selected damper material indicate, that both the dynamic spring rate and the loss-factor (damping) increases with frequency, and it is evident again, that thorough understanding of the working conditions is required to achieve a successful design.

**Effect of Temperature:** Due to the particular thermomechanical behaviour of elastomeric material, the temperature is a third important parameter which has considerable influences on damper efficiency. Figure 34 shows representative effects of ambient temperature on the dynamic characteristics of a silicon type of damper. At very low temperatures a stiffening effect in the spring rate is seen, which is an important consideration in the cold start characteristics of a BMR design.

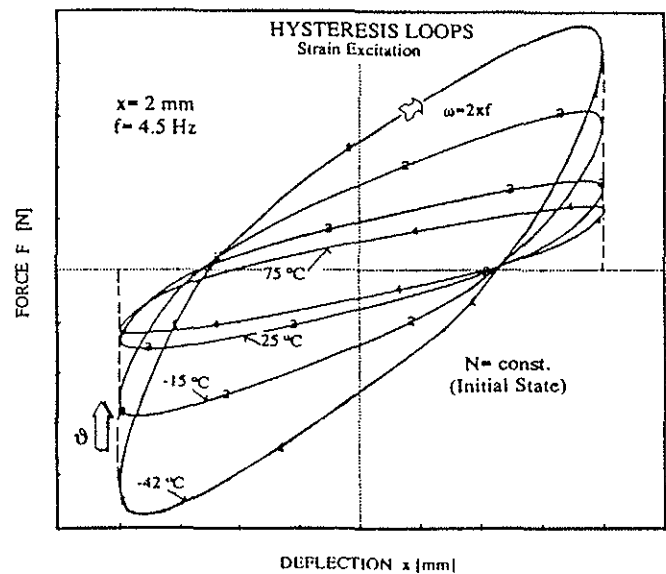

Fig. 34 Damper characteristics as a function of ambient temperature

In this context, the self-heating effect on damper characteristics during the run-up time is of importance. These effects have been thoroughly investigated through experiments during the recent years. The results show that the materials used today, even at very low temperatures show a rapid softening due to the selfheating effect, requiring only a very small number of cycles during rotor run-up.

As an example, a complete coupled thermo-viscoelastic analysis of the internal temperature field inside a damper with metal shims is presented in Figure 35. The picture shows the local temperature concentrations through internal heat buildup for a maximum amplitude case, as analyzed by FEM. The silicon rubber material can well accommodate the temperature levels shown here. The cooling effect of the two metal shims can clearly be seen. The peak temperature inside the damper would be significantly higher without the metal shims.

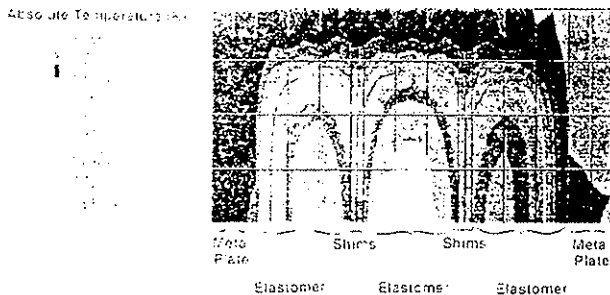

Fig. 35 Calculated temperature distribution inside an elastomeric damper (max. amplitude case)

**Analytical Modelling:** Due to the particular non-linear behaviour of elastomeric materials, the requirements for the analytical formulation and the procedures in the design process have changed. Pure mechanical damping can no more be treated as a simple linear term, and chordwise stiffness is no longer a constant parameter. It is important to consider that these values are depending on the operational conditions such as lead-lag amplitude, frequency and ambient temperature, for example. Hence, non-classical effects of this nature have to be incorporated into the dynamic modelling of a bearingless rotor.

Figure 36 shows a simplified steady-state model for the prediction of the modal characteristics and the aeroelastic stability behaviour, including a specific model for the elastomeric damper. The non-linear system is solved in a stepwise manner.

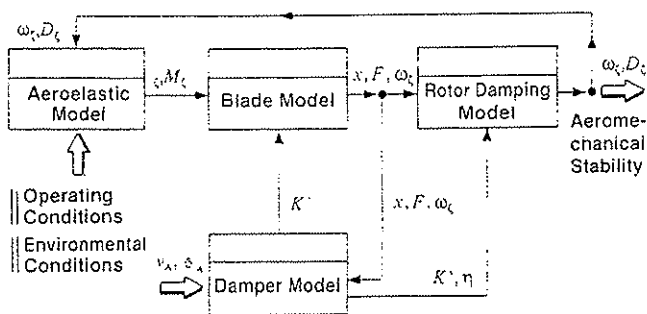

Fig. 36 Non-linear dynamics modelling

### Achievements to Date and Prospects

The bearingless-rotor development efforts to date have reached a status, where a critical assessment of the achievements can be made and where future perspectives should be given.

### Aeromechanical Stability Developed

Aeromechanical stability of the ground and air resonance type - a major concern in the early design - can be considered to be sufficiently developed today, as can be seen from the damping levels achieved in the various testings (References 14, 39). Inplane damping typically lies in the order of 3 to 4 percent (Figure 37). Quite obviously, the stabilizing effects of coupling parameters are understood, although other design requirements do not always allow the application of the optimum choice.

The technology of elastomeric dampers, most commonly used on the BMR-designs today, has also rapidly developed in the past decade and the understanding of the main material characteristics has strongly improved. Although, some questions have still to be finally answered to master this technology. Further work has to be done in the improvement of life-time, definition of replacement criteria, unsymmetric operations and failure analysis, for example.

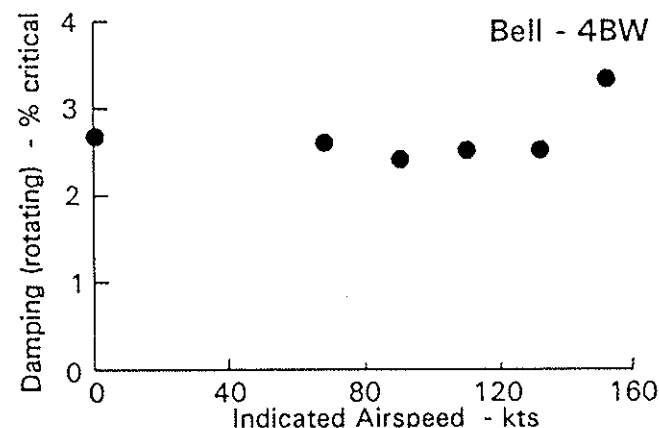
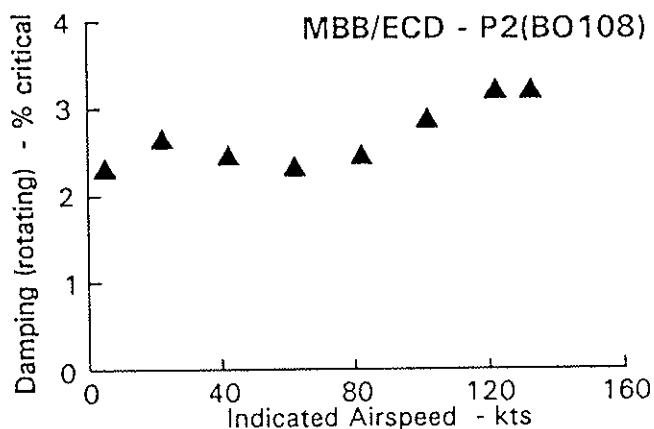

Fig. 37 Typical rotor lead-lag damping levels in flight



From the technological standpoint, the question is sometimes raised, whether such elements could even be completely dispensed in future BMR-designs. From the today's view, a complete elimination looks not likely, but any efforts should be made to minimize the damper size and the required operating amplitudes, in order to increase life-time.

### Good Ride Qualities

A discussed, handling qualities and vibrations depend mainly on the hub-moment stiffness, and are not directly characteristic for the type of hub design itself. Nevertheless, the experiences gained from the handling qualities evaluations of past BMR's flight testing is in all cases very positive: The Bell 222 with a low (2,5...4 percent) hinge-offset Model 680 BMR showed significant improvements in the piloting efforts; the measured 4/rev-vibrations, particularly with the LIVE-units installed, were very low (Figure 38).

Beneficial handling qualities and vibrations were also confirmed by the BO 108 BMR prototype testing. The bearingless rotor with 9 percent hinge-offset provided the aircraft very pleasant control response, improved stability characteristics, and very good ride quality, in general. With a passive anti-resonance vibration system (ARIS) installed, the vibration levels were also highly satisfactory, with 4/rev-levels well below 0.1 g over the whole flight envelope, at all seats and in all axes (Figure 38).

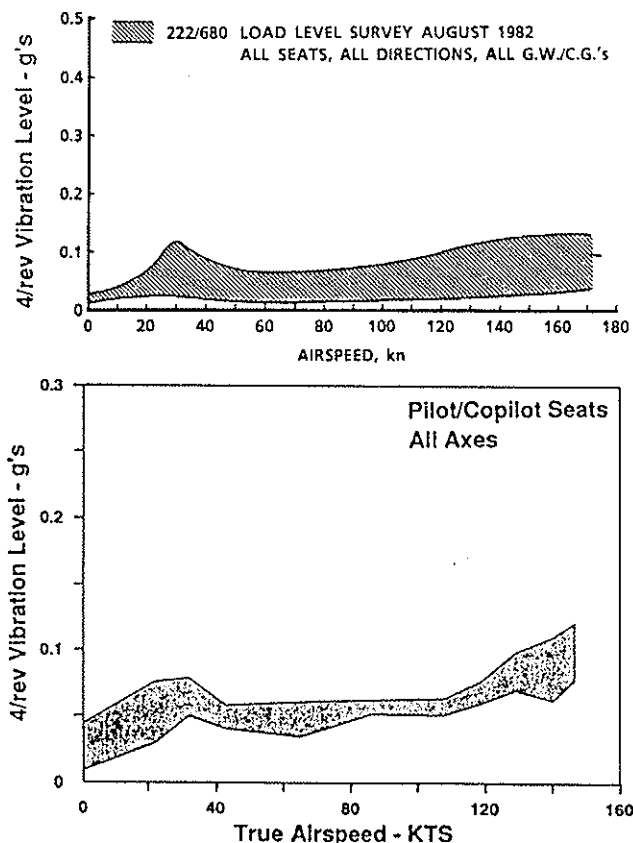

Fig. 38 Fuselage vibrations on BMR-aircraft (Top: Bell 222/680; Bottom: MBB BO108/BMR)

### Low Weight

Simplicity and its favourable implications for rotor system weight is one major goal in BMR design. Although the data weight available is not enough to provide a reliable basis for such comparison, a rough assessment of the current informations should be of interest (Figure 39).

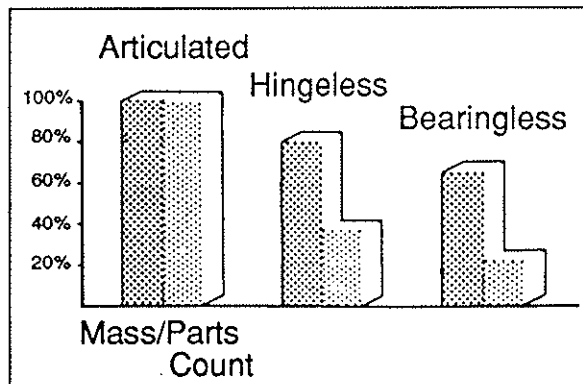

Fig. 39 Relative rotor weight and complexity

Boeing Vertol, on the basis of its experimental design, gave an early estimate for a production BMR, which would be 22 percent lighter when compared to the BO 105 hingeless rotor. Aerospatiale's Triflex hub was reported to be 48 percent lower in weight than the corresponding standard SA 341 Gazelle hub. This would compare to a weight saving of roughly 20 percent on the complete rotor. Bell, from the experience with its Model 680 rotor with 412 type of blades, shows a 9 percent lighter hub weight, which would increase to 15 to 20 percent saving with new blade designs. MBB/ECD's experience shows savings in rotor system weight of 40 kg (18 percent) on its first BMR-prototype, and of 50 kg (22 percent) in the BO-108-BMR design, when compared to the BO 105 hingeless rotor.

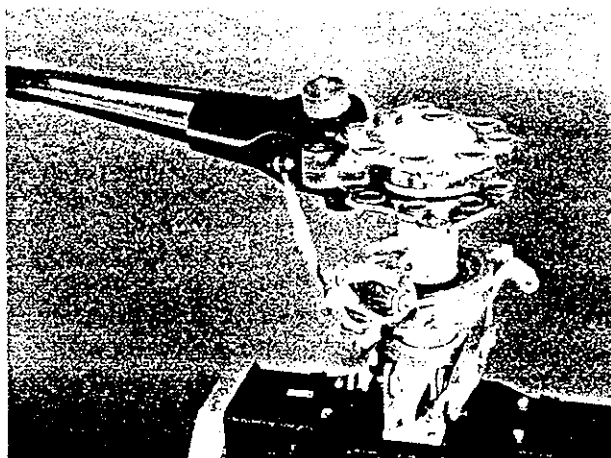

Fig. 40 Simplicity of BO108 BMR design

The reasons for the substantial weight savings are the simplification of the hub design and the intensive use of composite materials, as is evident from the BMR hardware shown in Figure 40. The composite material systems used in the design of modern bearingless rotors (hubs and blades) account for around 60 percent of the total materials used, as compared to only 12 percent for older articulated or 35 percent for hingeless rotors.

### Lower Manufacturing Efforts

In examining progress in this field, parts count is a quite descriptive parameter. A high parts count is generally typical of older conventional designs, in which a system of hinges and bearings is applied on the hub. Again, based on the small data base of bearingless rotor designs, the reductions in parts count range from 50 percent (Bell) up to about 85 percent (Aerospatiale), compared to older articulated designs. In comparison to more modern designs (like hingeless rotors), the reduction is in the range of 40 percent (MBB/ECD), Figure 39.

### Improved Reliability and Maintenance

The relevant drivers with respect to maintenance efforts and operating costs of conventional designs are wearing parts as bearings and joints and all life-time critical components. The progress in the new technology design stems from the fact that these parts are replaced through composites which allow for unlimited fatigue-life and show pronounced damage tolerance features inherent to their fibrous nature. Similarly, mechanical degradation in the elastomeric part shows also typical damage tolerant behaviour.

An evaluation of the fatigue characteristics indicates that, with careful design, life in excess of 10,000 hours is achievable in the composite parts. The numbers for elastomeric dampers are projected today to at least 2500 hours. These data are unquestionably a big step forward towards full on-condition replacement.

### Application to New Products

It is the result of the past 10 to 15 years' research and experimental work that bearingless rotor systems are suitable for production rotors today. Recognizing the requirements for advanced components, three major new-generation civil and military projects have selected the all composite BMR system as their prime lifting device (Figure 41): The ECD BO108 (flying since 1988), the MDHC Explorer (due to fly mid 1992), and the Boeing Sikorsky Comanche (first flight scheduled for 1995). Bell did not specify to what extent its Model 680 or 4BW technology will go into production for its new products.

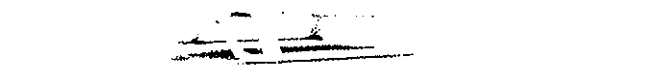
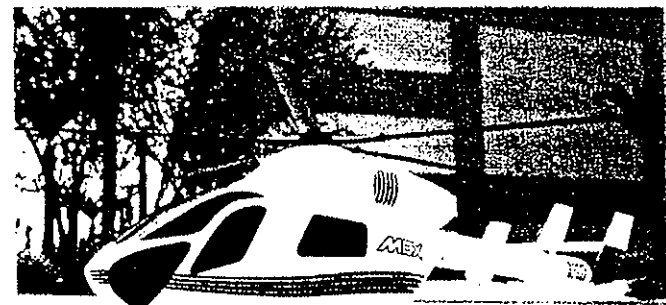
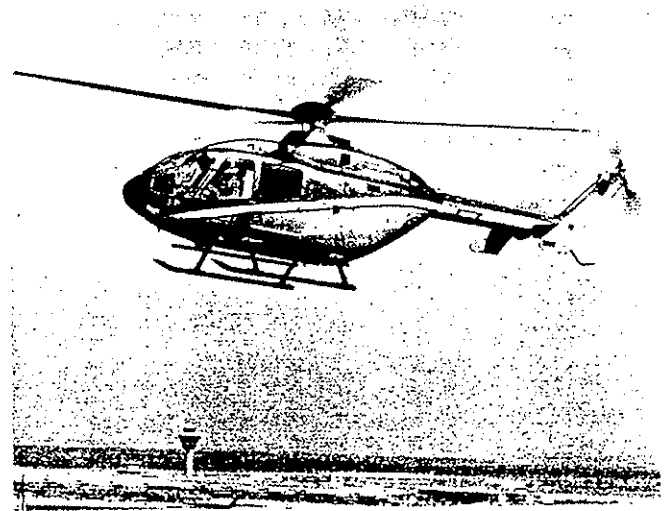

Fig. 41 ECD BO108, MDHC Explorer and Boeing Sikorsky Comanche using composite BMR systems

The expectations of the manufacturers are to take full advantage of the simplified design, the improved flight efficiency, the increased reliability and low weight, which are enabled through the introduction of the bearingless main rotor concept.

## A Look to the Future

Despite all the progress made during the past decade, it can be imagined that aeromechanics and composite structural technology will not slow down in the future. Scientists and rotor design engineers will continue in thinking and creating new ideas how to make rotors better again. There are two innovative technologies coming up to date, and these are the HHC/IBC technology and, probably even more promising, the smart materials/structures technology. Currently, there are many research and experimental efforts running, to work out the fundamental technologies and to check the proof of concepts (Reference 40, 41 for example).

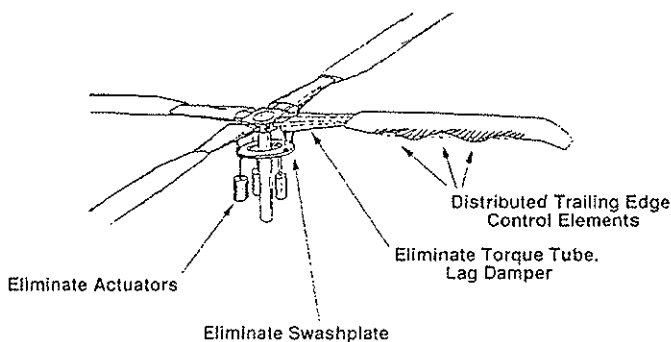

Fig. 42 "Ideal" concept possibilities

How "ideal" rotor concept possibilities could look like in the future, is shown in Figure 42, taken from Reference 42. The technology assessment indicates, that some of the required disciplines are ready today and some of them have still to be pushed forward. In this context, the aeroelastic and structural technology, worked out during the bearingless-rotor technology development, unquestionably, is an excellent basis for a full integration of smart material "actuators" within an "Intelligent Rotor".

## Conclusions

There has been substantial progress in the design and development of bearingless main rotor concepts in the past decade. Nearly all of the helicopter manufacturers have worked, among other rotor systems, toward the development of bearingless-rotors, with different design approaches and with different success.

The most common bearingless-rotor configuration today involves a flexbeam with an inboard flap flexure, plus an external pitch cuff, supported by a snubber/damper at the root for the control of the pitch/bending coupling and augmentation of the structural damping. The main secrets lie in the proper design of the flexible element, and of the

damping elements. They have to accommodate the flexible blade bending and pitch-control motions, and to provide the required in-plane damping.

The successful development of such components requires an interactive approach: Material properties, load and modal analyses, kinematic/elastic coupling effects and non-linear elastomeric properties must be interactively optimized to assure proper stress distributions, adequate frequency and damping characteristics, and general structural integrity. The extensive and often non-linear finite elements analyses required within this process are available today, and most of the complex influences are understood today. Although, some questions have still to be finally answered, to fully master this technology.

A review of the recent accomplishments indicates that the aeromechanical stability of the soft-in-plane design is developed, and it is evident, that the realized concepts provide excellent flying characteristics and low vibration levels. These advantages are achieved with simplified hub designs and through a rigorous usage of composite materials, which lead to a substantial saving of weight, lower manufacturing efforts, improved reliability and reductions in maintenance.

Three new helicopter projects have selected the bearingless-rotor technology as their prime lifting device: The BO108, the Explorer and the Comanche. They are in different stages of development.

It can be imagined that aeromechanics and composite structures technology will continue to develop. New technologies are on the horizon today, which, together with the existing bearingless technology base, could lead to the "Intelligent Rotor" within the next decade.

## References

1. Fenaughty, R.R., and Noehren, W.L., "Composite Bearingless Tail Rotor for UTTAS", *Journal of American Helicopter Society*, Vol. 22, No. 3, July 1977
2. Shaw, J., Jr., and Edwards, W.T., "The YUH-61A Tail Rotor: Development of a Stiff-Inplane Bearingless Flexstrap Design", *Journal of American Helicopter Society*, Vol. 23, No. 2, April 1978
3. Banerjee, D., Head, R.E., Marthe, R. and Ploudre, M., "The YAH-64A Composite Flexbeam Tail Rotor", *AHS-Specialists Meeting on Rotor Design*, Philadelphia, Oct. 1980
4. Blachere, C., and D'Ambra, F., "Tail Rotor Studies for Satisfactory Performance, Strength, and Dynamic Behaviour", *Vertica*, Vol. 6, No. 4, 1982

5. Huber, H., Klöppel, V. and Enekl, B., "Development of Bearingless Tail Rotors", RAE's and AHS Helicopter Yaw Control Concepts Conference, London, February 1990
6. Donham, R.E., Cardinale, S.V., and Sachs, I.B., "Ground and Air Resonance Characteristics of a Soft Inplane Rigid Rotor System", Journal American Helicopter Society, Vol. 14, No. 4, Oct. 1969
7. Staley, J.A., Gabel, R., and Mac Donald, H.J., "Full Scale Ground and Air Resonance Testing of the Army-Boeing Vertol Bearingless Main Rotor", American Helicopter Society 35th Annual National Forum, Washington D.C. May 1979
8. Dixon, P.G.C. and Bishop, H.E., "The Bearingless Main Rotor", Journal American Helicopter Society, Vol. 25, No.3, 1980
9. Mouille, R., "Design Philosophy for Helicopter Rotor Heads", Second European Rotorcraft and Powered-Lift Aircraft Forum, Bückeburg, Germany, September 1976
10. Cassier, A., "Development of the Triflex Rotor Head", Fifth European Rotorcraft and Powered-Lift Aircraft Forum, Amsterdam, September 1979
11. Metzger, R., "Smooth and Simple: The Bell Model 680 Bearingless Main Rotor", Vertiflite, Vol. 29, No. 4, May-June 1983
12. Weller, W.H., "Correlation and Evaluation of Inplane Stability Characteristics for an Advanced Bearingless Main Rotor Model", NASA CR-166448, May 1983
13. Alsmiller, G., Metzger, R., and Sonneborn, W., "All-Composite Rotorcraft", American Helicopter Society, 39th Annual Forum, St. Louis, May 1983
14. Harse, J.H., "The Four-Bladed Main Rotor System for the AH-1W Helicopter", American Helicopter Society, 45th Annual National Forum, Boston, May 1989
15. Banerjee, D. and Silverthorn, L.J., "Dynamic Considerations in the Design and Flight Test of an Advanced Bearingless Rotor System", American Helicopter Society, 45th Annual National Forum, Boston, May 1989
16. Head, R.E., Alexander, J.V., and Hughes, C.W., "Design of the McDonnell Douglas Helicopter Company Advanced Composite Rotor System", American Helicopter Society, 42nd Annual National Forum, Washington D.C., 1986
17. Fradenburgh, E.A. and Dr. Carlson, R.G., "The Sikorsky Dynaflex Rotor -an Advanced Main Rotor System for the 1990's", American Helicopter Society, 40th Annual Forum, Arlington, Virginia, May 1984
18. Blackwell, R.H., "Dynamics Considerations in the Design of the Comanche Helicopter", Fourth Workshop on Dynamics and Aeroelastic Stability Modeling of Rotorcraft Systems", University of Maryland, Washington, November 1991
19. Huber, H., "Gelenk- und Lagerloser Hauptrotor in Faserverbundbauweise für dynamische Systeme zukünftiger Hubschrauber", 3. BMFT Status Seminar Luftfahrtforschung und -technologie, Hamburg, May 1983
20. Seitz, G. and Singer, G., "Structural and Dynamic Tailoring of Hingeless/Bearingless Rotors", Ninth European Rotorcraft Forum, Stresa 1983
21. Klöppel, V., Kampa, K., Isselhorst, B., "Aeromechanical Aspects in the Design of Hingeless/Bearingless Rotor Systems", American Helicopter Society, 40th Annual National Forum, Washington 1984
22. Strehow, H., Frommlet, H., "Entwicklung Neuartiger Lagerloser Rotorsystem", 4. BMFT-Statusseminar Luftfahrtforschung und Luftfahrttechnologie, München, April 1986
23. Huber, H., "BO108 Development Status and Prospects", 16th European Rotorcraft Forum, Glasgow, September 1990
24. Juggins, P.T.W., "Substantiation of the Analytical Prediction of Ground and Air Resonance Stability of a Bearingless Rotor, Using Model Scale Tests", 12th European Rotorcraft Forum, Garmisch-Partenkirchen, Sept. 1986
25. Harse, James H., "Integrated Technology Rotor/Flight Research Rotor (ITR/FRR) Concept Definition", NASA CR 166443, 1983
26. Dixon, Peter G.C., "Integrated Technology Rotor/Flight Research Rotor Hub Concept Definition", NASA CR 166447, 1983
27. Hughes, Charles W., "Integrated Technology Rotor/Flight Research Rotor (ITR/FRR) Concept Definition Study", NASA CR 16444, 1983
28. Howes, H.E. and Tomashofski, C.A., "Integrated Technology Rotor/Flight Research Rotor (ITR/FRR) Concept Definition", NASA CR 166445, 1983
29. Carlson, Raymond G., Beno, Edward A., and Ullisnik, Harold D., "Integrated Technology Rotor/Flight Research Rotor (ITR/FRR) Concept Definition Study", NASA CR 166446, 1983

30. Bousman, W.G., Ormiston, R.A., and Mirick, P.H., "Design Considerations for Bearingless Rotor Hubs", American Helicopter Society 39th Annual National Forum, St. Louis, May 1983
31. Reichert, G. and Oelker, P., "Handling Qualities with the Bölkow Rigid Rotor System", American Helicopter Society 24th Annual National Forum, Washington D.C., May 1968
32. Huber, H., "Parametric Trends & Optimization - Preliminary Selection of Configuration - Prototype Design and Manufacture", AGARD-LS-63, 1973
33. Hohenemser, K.H., "Hingeless Rotorcraft Flight Dynamics", AGARDograph No. 197, September 1974
34. Johnson, W., "Recent Developments in the Dynamics of Advanced Rotor Systems", AGARD-LS-139, 1985
35. Ormiston, R.A. and Hodges, D.H., "Linear Flap-Lag Dynamics on Hingeless Helicopter Rotor in Hover", Journal of the American Helicopter Society, Vol. 17, No. 2, 1972
36. Huber, H.B., "Effect of Torsion-Flap-Lag Coupling on Hingeless Rotor Stability", American Helicopter Society 29th Annual National Forum, Washington, May 1973
37. Jang, J. and Chopra, I., "Ground and Air Resonance of an Advanced Bearingless Rotor in Hover", Journal of the American Helicopter Society, Vol. 33, NO. 3, July 1988
38. Hausmann, G. and Gergely, P., "Approximate Methods for Thermoviscoelastic Characterization and Analysis of Elastomeric Lead-Lag Dampers", Eighteenth European Rotorcraft Forum, Avignon, 1992
39. Schimke, D., Enenkl, B. and Allramseder E., "MBB BO108 Helicopter Ground and Flight Test Evaluation", Fifteenth European Rotorcraft Forum, Amsterdam, Sept. 1989
40. Hanagud, S., Babu, G.L.N., Won, C.C. and Obal, M.B., "Smart Structures for Helicopters", Sixteenth European Rotorcraft Forum, Glasgow, September 1990
41. Chen, P.C., Samak, D.K. and Chopra, I., "Development of an Intelligent Rotor", Fourth Workshop on Dynamics and Aeroelastic Stability Modeling of Rotorcraft Systems", University of Maryland, Washington, November 1991
42. Ormiston, R.A., "Can Smart Materials Make Helicopters Better?", Fourth Workshop on Dynamics and Aeroelastic Stability Modeling of Rotorcraft Systems", University of Maryland, Washington, November 1991