



Flight Evaluation of a  
Helmet Mounted LED Matrix Display  
in a Lynx Helicopter

A. CORT

WESTLAND HELICOPTERS LTD

YEOVIL

ENGLAND

16-19 SEPTEMBER 1980

The University . Bristol . BS8 1HR . England

FLIGHT EVALUATION OF A HELMET MOUNTED LED MATRIX DISPLAY IN A  
LYNX HELICOPTER

A. Cort, Westland Helicopters Ltd.  
Advanced Systems Department

SUMMARY

A helmet mounted head-up display which could be useful for pilots of battlefield helicopters has recently been evaluated by Westland in a Lynx helicopter.

The head-up display method of providing pilots with flight or weapons information while allowing them to watch outside the cockpit is well known. In fixed wing aircraft an image is projected onto the pilot's windscreen so that it is superimposed on the scene outside. In helicopters this method is unsatisfactory due to the wider field of view needing to be scanned by the pilot.

A possible answer is to project the image onto a visor attached to the pilot's helmet. This then moves with his head and, as the image is focussed on infinity, does not distract his attention from vital ground or airborne cues.

Some attention is being given to helmet systems incorporating miniature cathode ray tubes, but the system evaluated by Westland is an alternative approach based on an array of light emitting diodes. The concept, developed by Marconi Avionics, relies on light from the LEDs being projected onto a portion of the pilot's visor which nevertheless remains transparent to light coming in from outside.

Westland tested a prototype on two test pilots flying multi-role Lynx XX153. Signals to fly up, down, left or right were generated artificially and indicated by appropriate bars displaced from the centre of the matrix as in an ILS type glide scope indicator. Later systems could be adapted to read out flight or weapons data, or other types of mission information.

After an initial learning period both test pilots found the system effective in conveying data, especially at low altitudes.

The study concluded that a helmet mounted display using LED-matrix technology could be a valuable aid to the helicopter pilot.

1. INTRODUCTION

The survival of a helicopter on a high intensity battlefield depends primarily on the field craft demonstrated by the pilot. He will be called upon to fly at extremely low level over a variety of terrain types, making maximum use of his vehicles' unique manoeuvrability, often at night and in poor weather. To avoid obstacles and maintain terrain clearance he must use the full field of view from his cockpit. It is therefore essential that his information displays minimise the need for him to spend long periods looking down within the cockpit. The situation is now being made even more demanding by the use of sophisticated weapons

and sensors which are being installed to increase the combat effectiveness of the vehicle. Head-up and helmet mounted displays are devices which have been developed to meet the need for improved information transfer.

The aircraft-mounted head-up display (HUD) has been used primarily in fixed wing aircraft. It presents information to the pilot by superimposing a collimated image of the display onto his outside field-of-view. The optical system of a HUD has to be large to enable the pilot to move his head and scan his forward view while ensuring that he never loses the information being presented to him. However, even advanced designs of HUD cannot include areas more than approximately  $30^{\circ}$  from the aircraft longitudinal axis, and this is not adequate for helicopter use other than for some weapon aiming applications involving precise delivery of munitions. There are also constraints on the viewing and installation geometry.

The helmet-mounted display is a logical extension of the aircraft-mounted HUD. Mounting the display optics on the helmet has the effect of making the display visible throughout the full range of the pilot's head movement, and the optical system can be made much smaller (Fig. 1 and 2).

The HMD is therefore of great potential value to the helicopter pilot through allowing head-up operation over a wider range of head movement than a HUD. Helmet systems incorporating miniature cathode ray tubes have been developed for use where T.V. type pictures must be displayed, for example imagery from low light level T.V. or Infra Red night vision aids. They are also suitable for presenting complex graphic information. The disadvantages of CRT presentation are the weight of the tube, (which can cause asymmetric loading of the neck) and the high voltages present at the helmet.

There are also circumstances in which the amount of information to be displayed does not require the full capacity of a CRT system. An alternative approach has been developed by Marconi Avionics which relies on a matrix array of light emitting diodes. This is smaller and lighter than a CRT and operates on lower voltages. The matrix size, although providing fewer picture elements than a CRT screen, is nevertheless large enough for a wide variety of symbols and formats to be generated.

In June 1977 a prototype HMD utilising LED technology was flown in a WML Gazelle. The device was worn by six WML test pilots and was operated by an experimenter from the passenger seat of the aircraft. Although the device was not connected to the vehicle systems, and was therefore open loop, the results of the trial were very encouraging. WML therefore undertook to carry out a more detailed examination of the HMD to prove in principle its useability and acceptability from human factors aspects. The study was carried out under MOD contract between May and September 1979.

## 2. DESCRIPTION OF EQUIPMENT

The HMD used in the trials was provided by M.Av. Ltd. and was an engineering prototype developed principally for laboratory trials. The display optics were mounted in a skeleton helmet. (Fig. 3).

The LED array is mounted on the helmet in front of the pilot's forehead, pointing downward. The visor in front of the pilot's right eye incorporates a spherical surface (combiner) and between the LED array and the combiner is a prism. This directs the light emitted by the diodes onto the combiner, on which there is a partially reflective coating enabling the display to be seen focussed on infinity and superimposed on the outside world. The coating is dichroic to reflect in the red region of the spectrum coinciding with the colour of the LED array (650 nm). The diagonal angle of the LED matrix subtends approximately  $7^{\circ}$  at the pilot's eye.

The array is in the form of a dot matrix of 23 columns and 20 rows onto which a wide range of symbols or alphanumerics can be written. The format of the symbology was controlled by electronics in an interface unit in a short half ATR box mounted on the cabin floor, immediately behind the interseat console (Fig. 4 and 5). A schematic of the complete installation is given in Fig. 6.

The parameters displayed were chosen to represent as far as possible a typical and realistic piloting task, and to be relevant to battlefield operations. Simple formats were adopted, to avoid electronic complexity and so that the existing aircraft sensor fit could be used.

The interface unit received signals from the:

- Radar Altimeter
- Tactical Navigation System

The signals were presented as a Flight-Path-Deviation display in the form of LED crosswires. The vertical bar displayed steering error information obtained from the TANS. The horizontal bar displayed altitude error information derived from the radar altimeter.

Both the heading and height bars flashed at set error limits on the display:

Height	$\pm 40$ ft	deviation from set height
Heading	$\pm 18^{\circ}$	deviation from set heading.

Two formats were used during the trials. The centre of the first format was indicated by four fixed illuminated LEDs. (Fig. 7A). The centre of the second format was indicated by eight fixed LEDs in the form of a diagonal cross. (Fig. 7B).

### 3. ASSESSMENT TECHNIQUES

The subjective evaluation of the test pilots was the principle source of information in the assessment programme. This was supplemented by objective assessment techniques sensitive to changes in the pilots activity brought about through the use of the HMD. These were measures of visual activity and of workload.

Eye scanning patterns may be recorded and evaluated using eye-mark cameras etc. These devices record the direction of gaze as a spot of light superimposed on a T.V. picture of the pilot's visual field. Generally some form of head mounted apparatus is required, but this is not compatible with the HMD, and consequently an alternative approach was considered based on analysis of head activity alone. This technique has been extensively used by Lovesey (Ref. 1). It is based on the observation that direction of regard can be inferred from the orientation of the head, and that gross changes in scanning patterns can therefore be detected non-intrusively.

In practice there are few suitable techniques for measuring workload during flight. Physiological techniques were ruled out because of the hostile electrical environment, small sample size etc. Eventually an auditory secondary task which had been used at the RAF Institute of Aviation Medicine in simulator trials was selected (Ref. 2).

The philosophy behind the secondary task method is to measure the workload associated with a primary task (in this case flying the helicopter) by inference from performance on a non-intrusive secondary task.

If the effort required to maintain primary task performance at a given level increases, then performance at the secondary task decreases. Conversely, if the primary task becomes easier, secondary task performance improves. The primary task consisted of three preset manoeuvres. These were;

- Maintain Straight and Level Flight on Set Height and Heading
- Climbing Turn Between Set Heights and Heading
- Descending Turn Between Set Heights and Heading.

The method of carrying out the secondary task test was for the pilot to respond to a series of numbers (between 0 and 9) quoted by the experimenter from a list of random digits. The pilot added three to each number and quoted the total back. This was repeated for a block of thirty digits. The pilot was instructed that he was to regard the flying task as his primary task, and to respond to the secondary task only when the primary task allowed. The pilot's head activity was video recorded during each task condition.

Immediately following each flight the test pilots' comments on the equipment were recorded. Each debrief was structured using a list of topics covering the major features of the equipment. The tapes were then transcribed and collated with tapes of inflight comments.

#### 4. FLIGHT PROGRAMME

The first test pilot completed approx.  $4\frac{1}{2}$  hours testing in five flights during which the equipment was assessed under as wide a range of conditions as possible. The majority of the programme was carried out over Sedgemoor to obtain steady radar altimeter signals. Adjacent undulating terrain was overflowed to assess the effect of rapidly varying height signals. Careful regard was given to flight safety, and for this reason the initial trials were carried out at 1,000 ft AGL.

The second test pilot completed approx.  $6\frac{1}{2}$  hours of testing in a further five flights. The first three flights repeated the majority of the exercises carried out by the first test pilot. The third flight included a simple navigation exercise. A more comprehensive exercise was carried out in the fourth flight. With increased confidence in the safety of the equipment, the final test flight was carried out at lower altitude (200 ft) along a low level route.

#### 5. RESULTS

Both test pilots initially found difficulty in assimilating information from the HMD. They reported that the display could be read clearly, but not while at the same time viewing the ground or looking for other aircraft. One pilot also reported difficulty in retaining the display when moving his head because of associated eye movements.

With increasing familiarity, both pilots reported that information could be assimilated more easily whilst viewing the ground, but it was still not possible to act upon that information without an attentional shift which 'blocked' information from the ground.

One pilot did not completely overcome this problem in his four hours. However, following a final low-level flight, the second pilot reported that he was able to act upon the displayed information while still viewing outside terrain, and that his ability to use the display without an attentional shift improved significantly.

Several factors appear to be responsible for this change. Practice effects were particularly important, as are the differences in outside view between 1,000 ft and 200 ft, e.g. changes in contrast levels. There is also a significant change in task content in that the pilot flies with greater reference to ground features at 200 ft.

Longer trials will be required to investigate the learning effects fully and trials over a greater range of altitudes will be necessary to establish at what heights attentional shift becomes a problem.

Neither pilot was aware of difficulties which could be directly attributed to the monocular presentation. Both pilots were aware of slight eyestrain particularly in their first two flights. Both commented that this lessened with increasing familiarity and appeared to be linked to the concentration required to view the display; it is therefore more likely to be linked with field-of-view, brightness and display content rather than monocular presentation alone.

Neither pilot had problems using the display off the fore-aft axis of the aircraft. There was no evidence of disorientation or control/display cross-coupling.

Vibration did not affect display legibility, although once per rev bounce ( 7 Hz) caused some involuntary head movement during rotor start up, but this did not last for more than one or two seconds.

Rotor flicker did not have any adverse effect on the display; even when looking directly up through the rotor on a very bright, sunny day. Rotor flicker occurs at approx. 24 Hz. Display refresh rate was at 153 frames per second.

The use of a matrix as a display surface did not cause any major difficulties. One pilot found that initially he regarded the bars as collections of dots rather than solid bars, and also that he was troubled by the discrete stepping of the bar from one matrix line to the next, but this effect disappeared with increased familiarity and was not reported by the second pilot.

The pilots took opposite views on the acceptability of having a clear-visor permanently installed in front of their eyes. One pilot found the visor obtrusive because of the prototype's low optical quality and the obstruction of vision at the edges of the visor and of the combiner. The obstruction in particular led to an effect described as 'tunnelling' of the pilot's vision.

The other pilot did not experience the same difficulty, and although the discontinuity between visor and combiner was considered annoying, the clear visor was accepted without problems. The first test pilot does not normally use a smoked visor, even on a very sunny day, but the second pilot uses a smoked visor frequently. It is felt that this difference in background and experience was the major factor affecting the pilot's response to the clear visor, and will be an important factor to be considered in achieving an operational system.

The last two flights included practical navigation exercises in which the heading bar was found to be very useful. The final flight was carried out at 200 ft and the pilot reported that he was able to look ahead, look for pylons, avoid obstacles etc. whilst still being aware of the heading bar, and was able to use the display to assist his navigation in a valuable manner.

Analysis of the video films taken during the trials showed that the differences between the HMD 'ON' and HMD 'OFF' test conditions were not large enough to produce detectable changes in the pattern of the pilot's head movements. It was concluded that when using the HMD at 1,000 ft there were probably only small magnitude changes in eye scanning patterns, though this might not be the case at lower altitudes.

The results of the auditory secondary task analysis suggested that the test pilots responded in quite different ways to the presence of the HMD. Because of the small sample size it was not possible to obtain results which were statistically significant and satisfactorily consistent, and despite the use of practice runs, there was indication that the secondary task was still being learnt during the test conditions. This merely confirms that much larger sample sizes and longer trials duration are required to collect meaningful statistical data.

Figure 8 shows the overall trend of the auditory secondary task results.

## 6. CONCLUSIONS

The study concluded that a helmet-mounted display using LED-matrix technology could be a valuable aid to the helicopter pilot.

The majority of the test flying was carried out at a relatively high altitude (1,000 ft AGL), and under these conditions there was no clear advantage to the HMD compared to conventional instruments, though it could be a useful alternative. However, during the limited low-level trials the test pilots found they could view the display with less difficulty than at higher altitudes. This effect appears to be connected with display brightness and the change in scene content between high and low levels. Further trials will be necessary to explore the low-level regime more thoroughly and to investigate a range of applications.

An improved HMD is under development utilising a larger matrix mounted in a Mk IV helmet, and this will eliminate the difficulties encountered with the skeleton helmet. For example the final development of the Mk IV HMD will employ a one piece visor with no inset combiner. This will eliminate the field-of-view intrusion caused by the combiner on the skeleton helmet.

Potential applications for a helmet mounted display system are numerous. However, most of these would apply to helicopters carrying more sophisticated avionics than in current service. Examples include target designation, weapon system displays, tactical or navigation displays, threat warning and wire warning displays, communications displays, etc. The justification for the cost of installing an HMD system must be that the information displayed is of high utility in the tactical, low-level environment. In the case of civil applications it must be shown that there is a benefit to the pilot in difficult terminal manoeuvres such as an approach to and landing on an Oil Rig. A similar requirement exists for Naval applications such as deck landings.

A further application for LED matrixes is the injection of display data into the optical path of night-vision-goggles and similar vision aids.

Westland will continue to evaluate the potential applications of HMDs both CRT and LED matrix type, and they will be incorporated in studies of advanced cockpit designs.



REFERENCES

1. Dr. E. J. Lovesey                      Head and Hand activity of a Sioux  
Helicopter Pilot.  
Royal Aircraft Establishment.  
Technical Memorandum E9546. 1973.
  
2. R. Green, R. Flux                      Auditory Communication and Workload.  
AGARD Conference Preprint No. 216:  
Methods to Assess Workload.  
AGARD CPP-216 (A4)1 - (A4)8. 1977

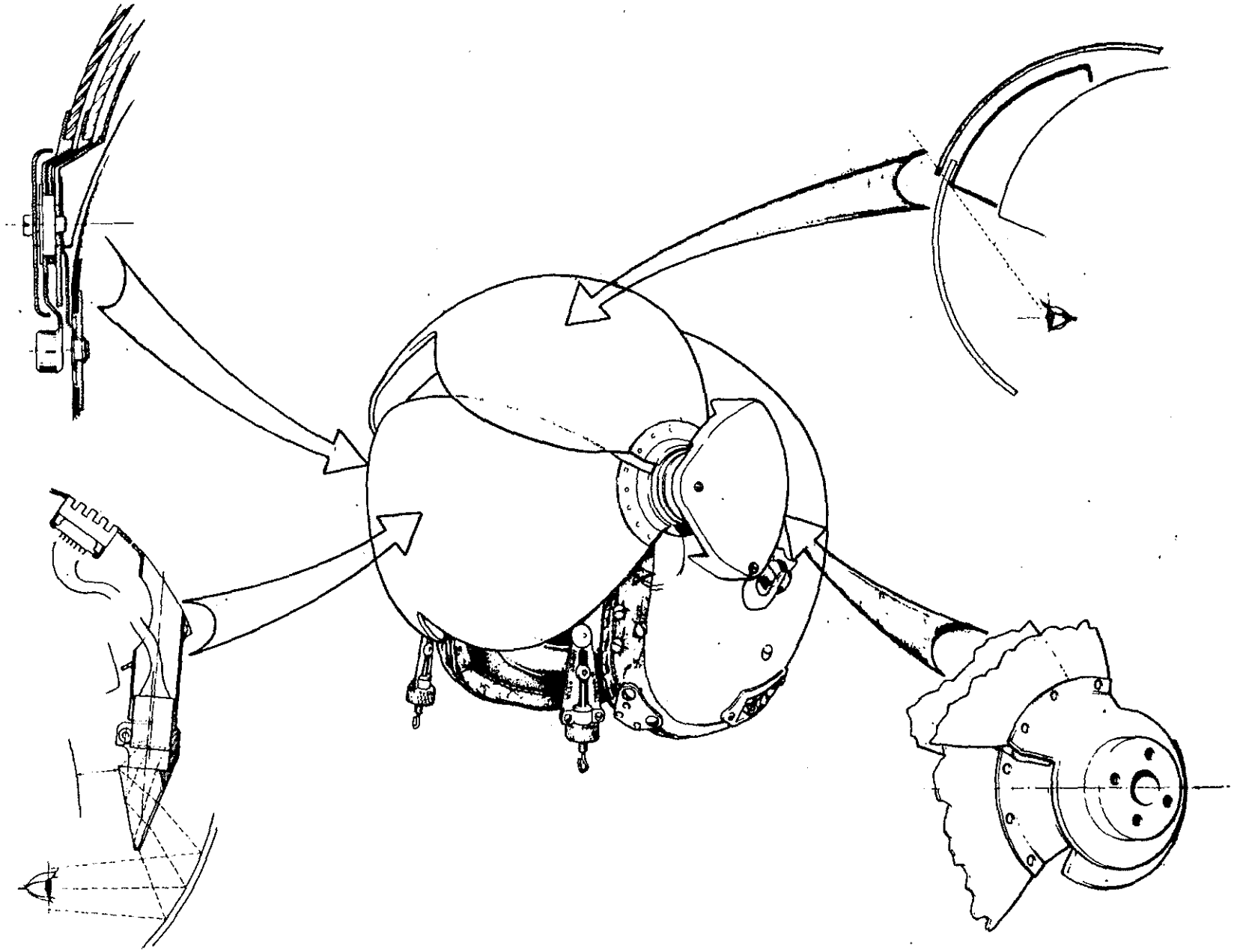

Helmet Mounted Display Fig 1

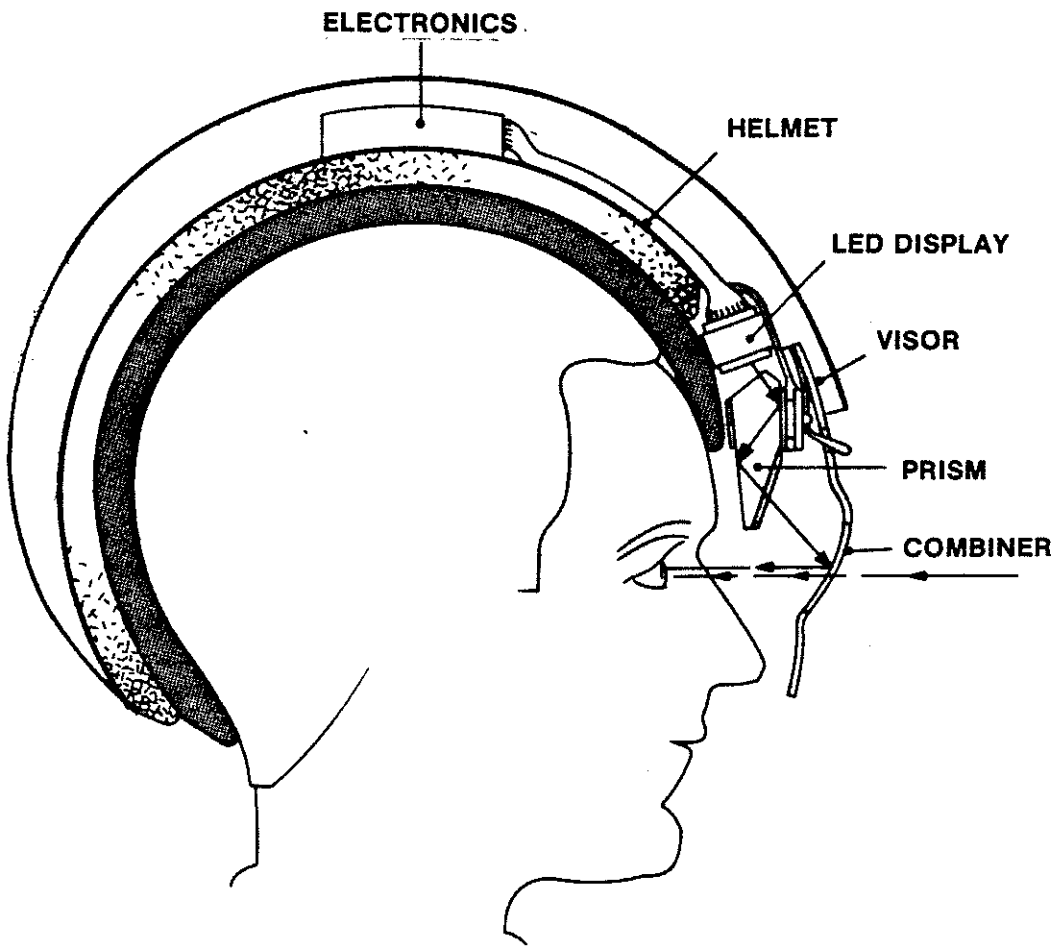

Optical Principle Fig 2

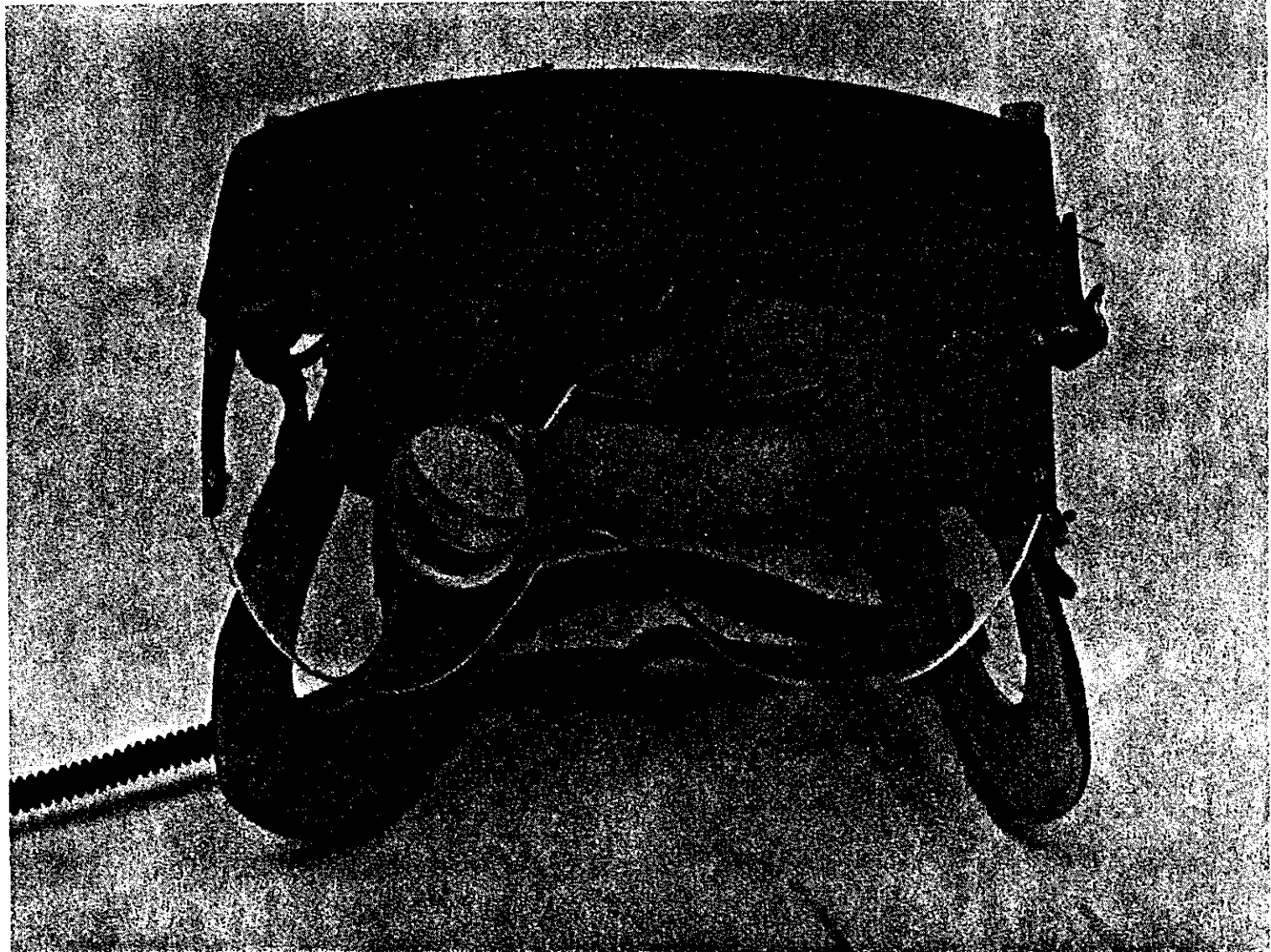

**Skeleton Helmet Fig 3**

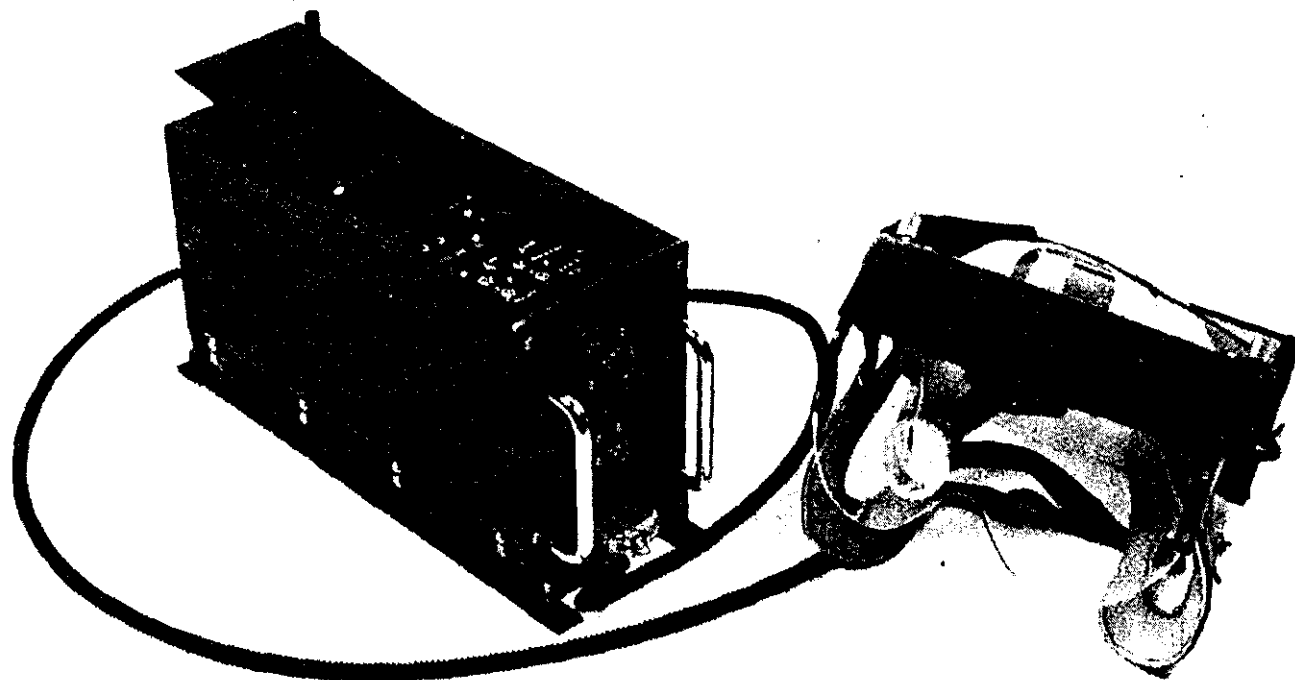

HMD and Interface Unit Fig 4

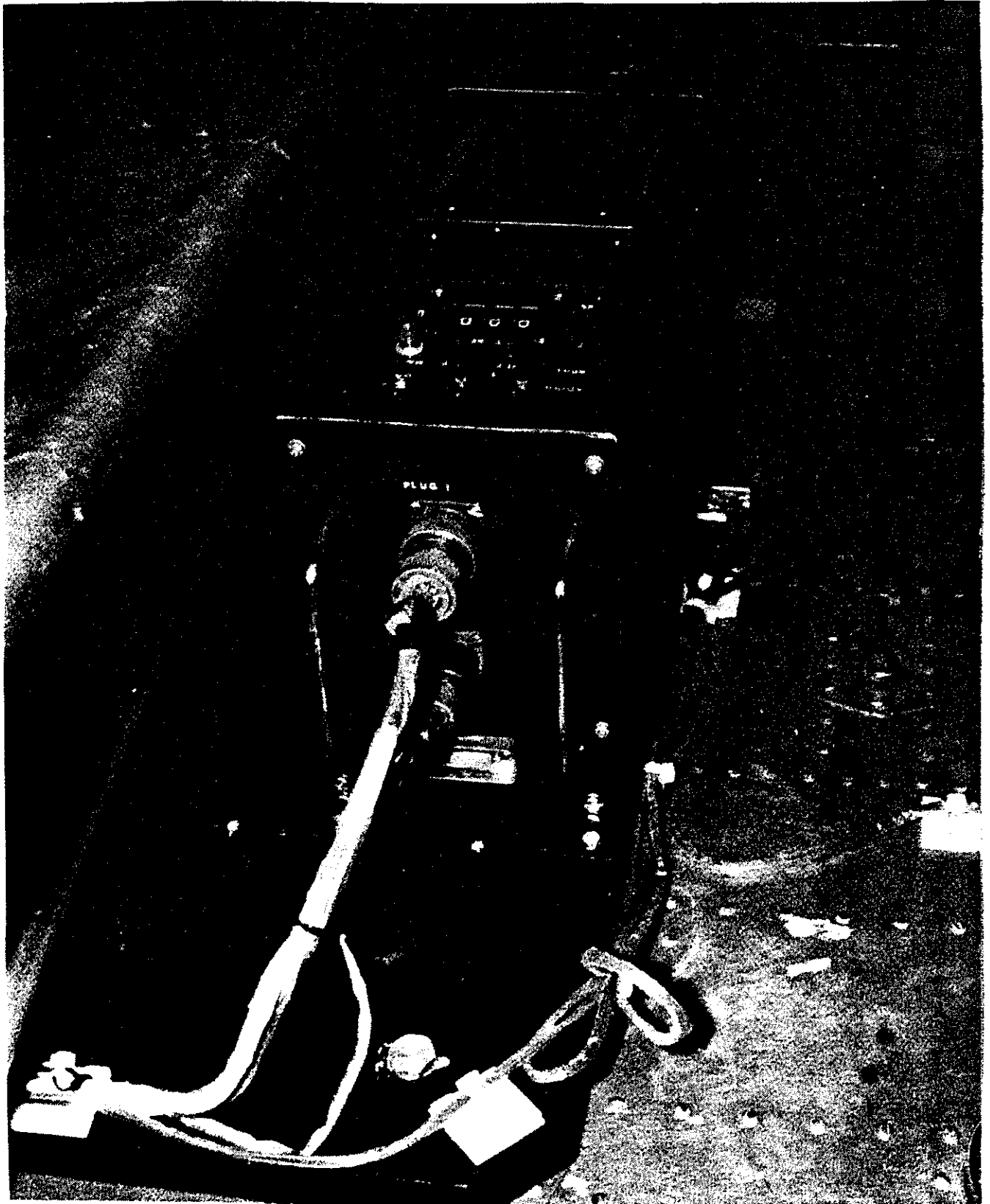

Interface Unit (Mounted) Fig 5

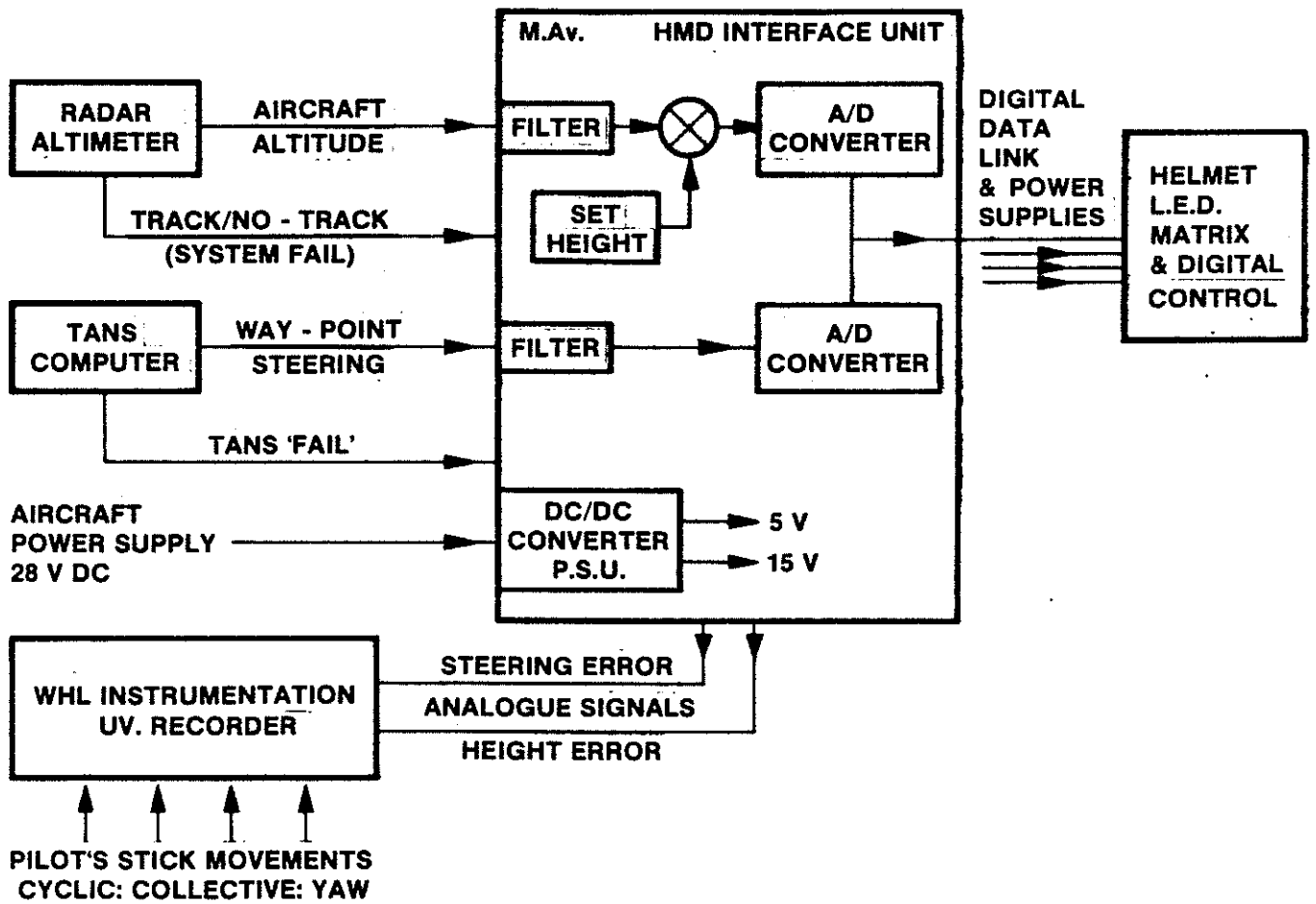

Schematic of Installation Fig 6

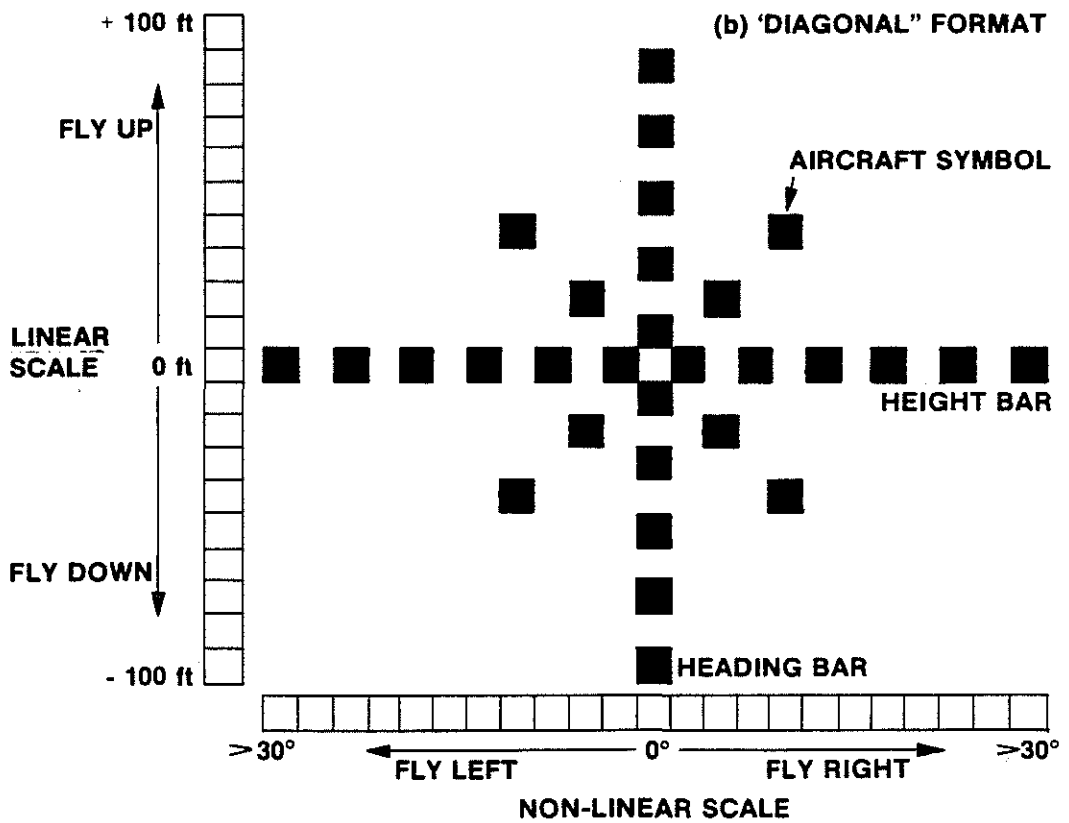
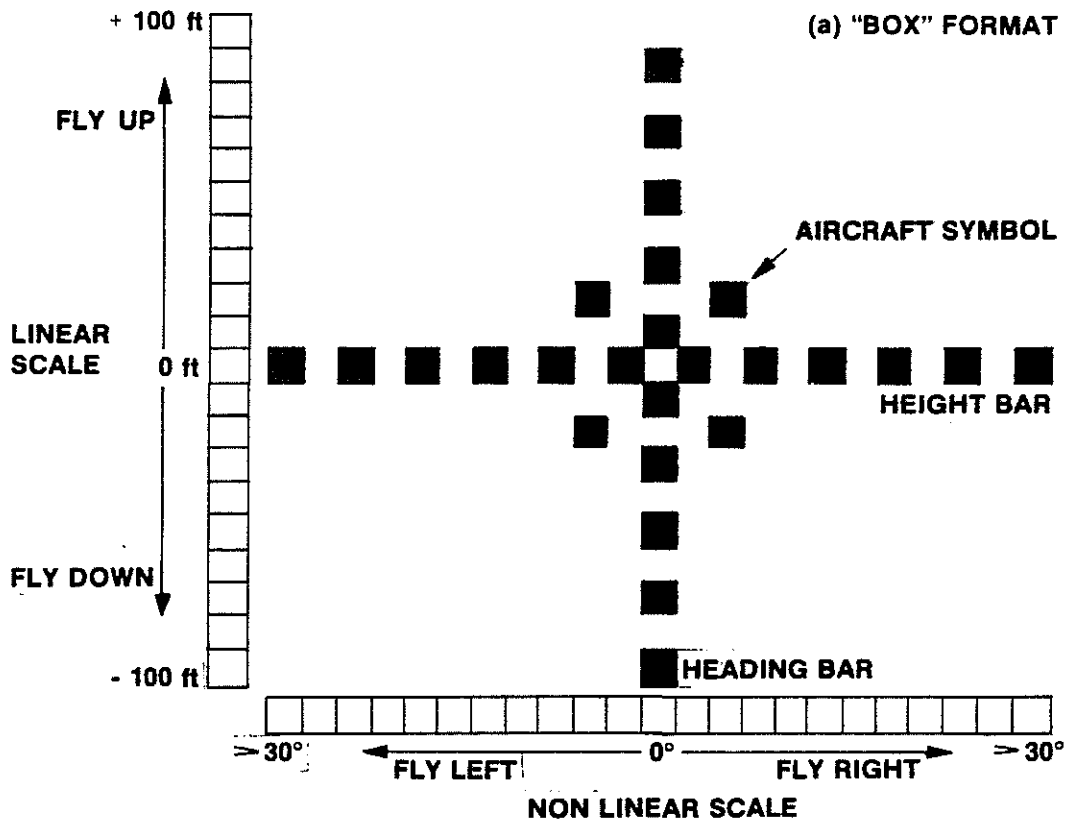

Display Formats Used In Flight Trials  
Fig 7a & 7b



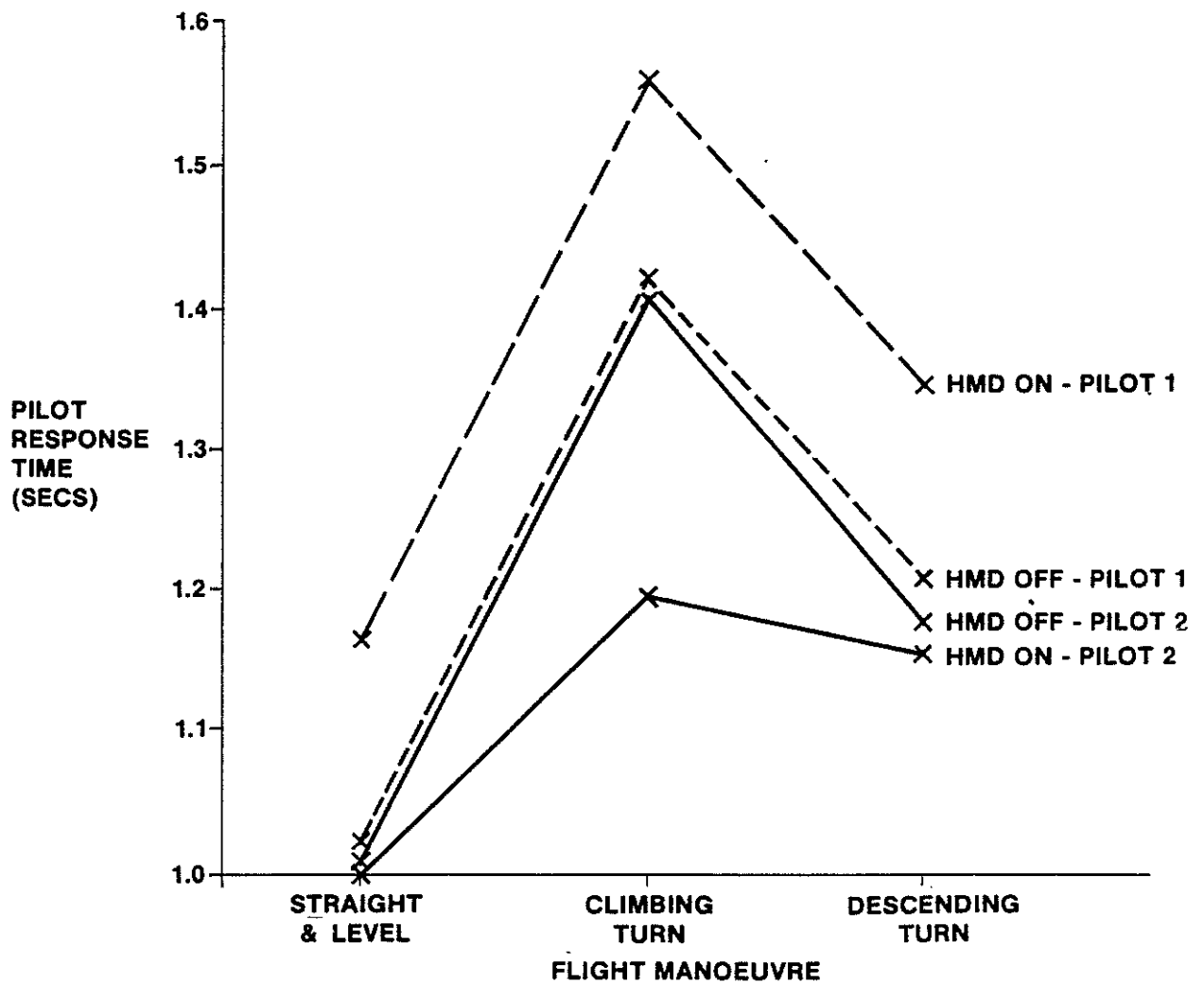

**Average Response Time To An Auditory  
Secondary Task Fig 8**