

THE EVOLUTION OF AIRBUS HELICOPTERS CRASHWORTHY COMPOSITE AIRFRAMES FOR TRANSPORT HELICOPTERS

Alexander Engleder, Johannes Markmiller, Roland Mueller
AIRBUS HELICOPTERS Deutschland GmbH

Abstract

Composite materials are nowadays widely used in helicopter airframe primary structures due to their specific inherent characteristics compared to conventional materials. The advantages of a design using composites compared to conventional designs (e.g. sheet/stringer in Aluminum) are for example a very competitive weight to volume ratio and an outstanding fatigue behavior.

AIRBUS HELICOPTERS has a long history in designing composite airframes which imply crashworthy features to ensure a high level of protection for the occupants in case of a crash. This paper shows the history of the composite airframe developments in AIRBUS HELICOPTERS and its predecessors and presents an approach developed for new commercial transport H/C programs.

Based on the experiences gained in previous research programs like the "BK117 Composite Airframe Program" and the ones gained in the development of the NH90, an approach has been developed to which extent the component requirements defined today in the relevant airworthiness regulations FAR/CS (e.g. emergency landing conditions general, emergency landing dynamic conditions, & fuel system crash resistance) will be implemented in future commercial HCs and how they will be complemented by an integrated system approach on airframe level in order to achieve AIRBUS HELICOPTERS in-house safety targets for the benefit of our customers. A smart trade-off between crash improvements and possible weight and cost penalties has to be conducted.

1. ABBREVIATIONS

AH – Airbus Helicopters

CFRP – Carbon Fibre Reinforced Plastic

CS – Certification Specifications

DLR – Deutsches Zentrum fuer Luft- und Raumfahrt

FAR – Federal Aviation Regulations

H/C – Helicopter

NHI – NATO Helicopter Industries

SFG – Sub Floor Group

2. INTRODUCTION

In the current airworthiness requirements for commercial transport category helicopters (FAR Part 29 and CS-29) there are dedicated requirements for subsystems which are linked to crashworthiness features like:

- Emergency Landing Conditions, (esp. for heavy masses in & around Cabin/Cockpit)
- Emergency Egress
- Landing Gears
- Seating systems and Cabin Interiors and
- Fuel System Crash Resistance

The aforementioned CS/FAR requirements ensure occupant survivability in case of crash. AH developed for its products a system approach to tailor and align several crash requirements, e.g. sinking speed, heavy mass retention, fuel system tightness, cabin volume reduction etc. to ensure occupant survivability and to trigger their influence on weight and cost.

From crash tests with airframes of legacy helicopters designed in the past, it is known that these airframes have a certain level of crashworthiness inherent in their design – even if not explicitly designed for it.

For future airframes of commercial transport helicopters in AIRBUS HELICOPTERS the approach is to use the already existing elements for subsystem crashworthiness and to complement them to a system design approach in order to take into account crashworthiness systematically during the development process.

Based on the experience and large database of existing test results together with nowadays state of art analytical tools for dynamic impact simulation an appropriate crashworthy design can be developed and validated.

This paper presents an approach using the example of the development of a new medium size helicopter,

3. BK117 COMPOSITE AIRFRAME PROGRAMME

For the BK117 helicopter a composite airframe (monolithic frames in CFRP & shells in KEVLAR/NOMEX sandwich, longerons & SFG bulkheads in CFRP/NOMEX sandwich) was developed and a prototype was tested extensively on ground and in flight (First Flight: May, 1989, see Fig.1). During this research program, which was funded by the German MoD, an extensive test program was conducted, which included among others crash sample tests on sub-component and component level of the sub floor group to investigate the performance of different design solutions w.r.t. energy absorbing capability, weight and recurring costs. This work was done in a cooperation with DLR, Stuttgart, Germany.



Fig.1: BK117 composite airframe demonstrator

The crash investigations were focused on the subfloor group (see Fig.2) under vertical crash loads. Different sandwich panel specimen were statically and dynamically crushed to study various crush initiators at e.g. panel skin intersections to investigate the different energy absorption capabilities (see Fig.3). Sub-component crash tests under quasi-static loading were concentrated on structural intersections of subfloor longerons (keel beams) and sub floor frames (bulkheads), see Fig.4 & Fig.5 resp. The components crash characteristics and the energy absorption capability were determined by drop tests. Various design solutions with e.g. notched corners at the intersections were considered with the aim to reduce the initial peak failure loads. Structural elements supporting the sub floor frames, where the skid landing gear is attached, were introduced to avoid global buckling

and to initiate and stabilize efficiently energy absorbing crash modes. The generated load-deflection characteristics were used as input for crash simulation calculations with computer code KRASH.

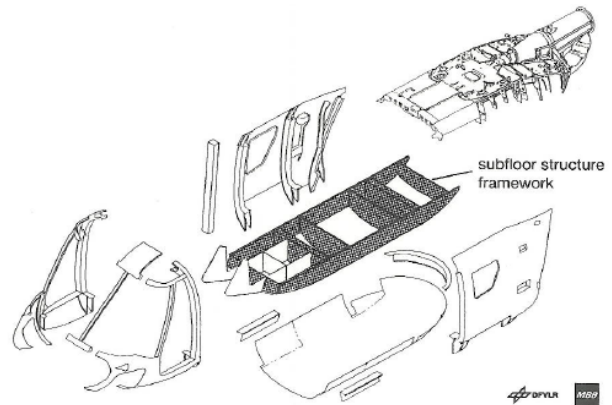

Fig.2: Structural breakdown of composite airframe

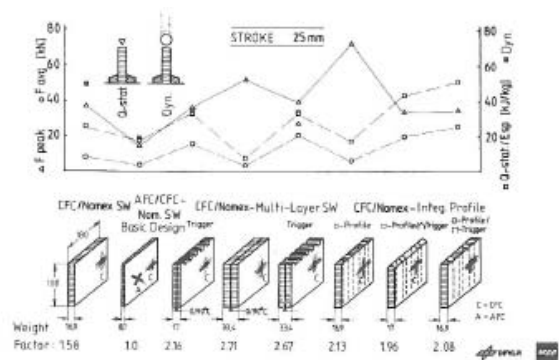

Fig.3: Different variants of sandwich panels (for keel beams & SFG frames) and their peak loads

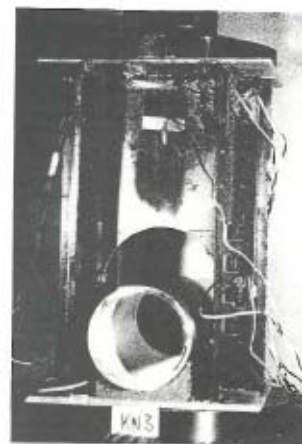

Fig.4: Test set up of an intersection component, longeron/frame

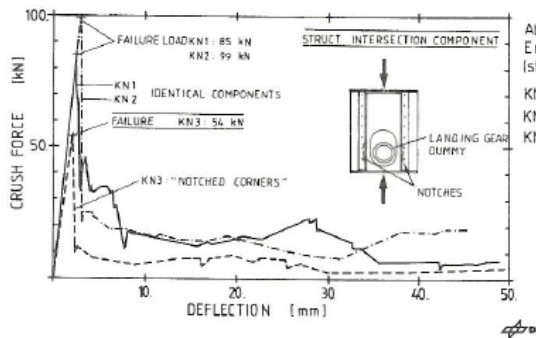

Fig.5: Measured force-deflection curve of test set up of an intersection component, longeron/frame

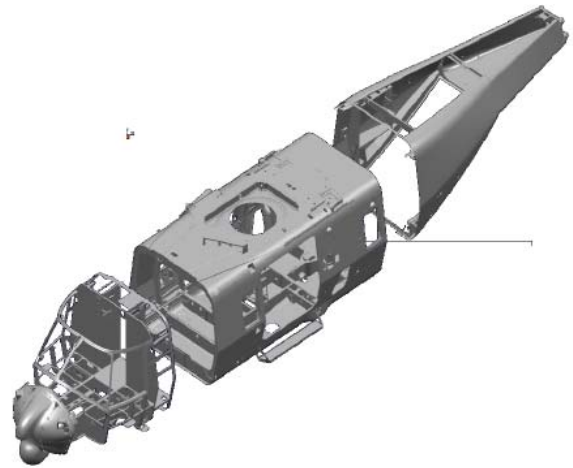

Fig.6: Full composite fuselage NH90

Within this research program elements of the composite sub floor group were identified and a test program on specimen and sub- component level was conducted to study the structural behavior under vertical crash loading.

For the composite airframe and especially for the sub floor group a favourable energy absorption performance was demonstrated through a test program. Special emphasis was placed on the design of intersections of longerons and frames. About 150 mm of stroke was available for energy absorption within the SFG. The BK117 composite airframe was expected to be suitable for a vertical crash condition of ~ 8 m/s. The system crashworthiness of the BK117 H/C could be studied with crash simulation calculations. The results of this research program and the experience gained on it were transferred to the design of the NH90 composite airframe.

4. THE NH90 COMPOSITE AIRFRAME

The NH90 is an NHI product. It is an industries partnership program that includes AIRBUS HELICOPTERS, AGUSTA WESTLAND and STORK FOKKER. There are basically two variants, a Tactical Transport Helicopter (TTH) and a NATO Frigate Helicopter (NFH). The maximum take-off weight is ~ 11 tons. The NH90 is the first H/C where for a transport H/C a full composite airframe (monolithic frames in CFRP, shells & SFG bulkheads in CFRP/NOMEX sandwich) was introduced into service (see Fig.6).

Survivability requirements for crash conditions have been defined on helicopter level:

The aim of the crashworthy design on H/C system level was to provide for crew and passengers the required level of survivability under crash conditions. This was among others achieved by using a set of energy absorbing subsystems like e.g. landing gear, fuselage subfloor group and crashworthy seats (see Fig. 7).

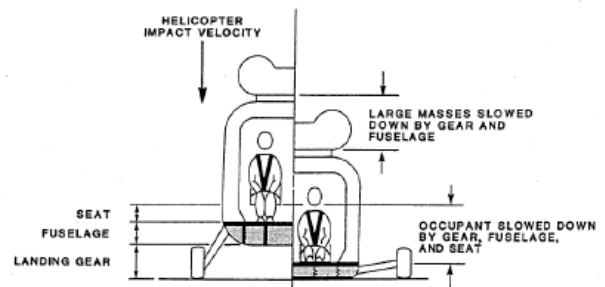

Fig. 7: H/C Energy management system

In addition specific design features to prevent occupants from hazards due to heavy masses on upper deck or in cabin/cargo compartment had to be implemented as well as measures to ensure a protective shell for them and a crashworthy fuel system which minimized the risk of a post-crash fire (see Fig.8).

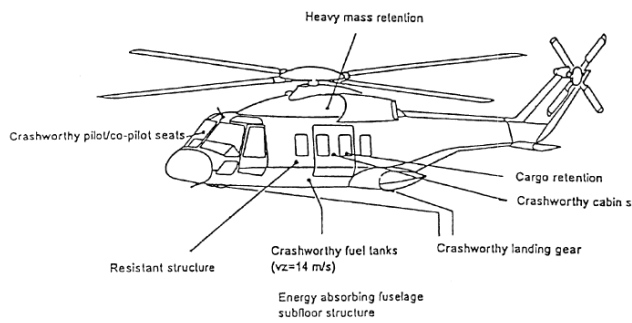

Fig.8: NH90 crash protection system

The survivability of occupants depends strongly on the envelope of the impact conditions. Important ones are the longitudinal, vertical, lateral and combined impact conditions, the roll-over capability, the high mass and cargo retention and the post-crash emergency escape provisions.

Survivability requirements posed on the NH90 fuselage:

For the fuselage a vertical impact velocity of ~8m/s w/o landing gear was defined. At this impact speed the fuselage has to maintain structural integrity, all heavy masses have to remain in place and the cabin volume has not to reduce more than 15%. The g-levels at the floor have to result in survivable g levels for occupants on crashworthy seats.

Structural characteristics of the fuselage:

The following structural characteristics of the NH90 fuselage contribute to the survivability of occupants.

- The subfloor group provides sufficient energy absorption to limit accelerations at floor to a level which is compatible with seat performance, see example Fig.9
- Specific design features provide a suitable energy dissipation to limit accelerations of heavy masses.
- The fuselage cockpit and cabin are designed in such a way that it is still a protective shell with sufficient structural integrity to ensure enough survivable volume for crew and occupants (The volume should not reduce more than 15%).

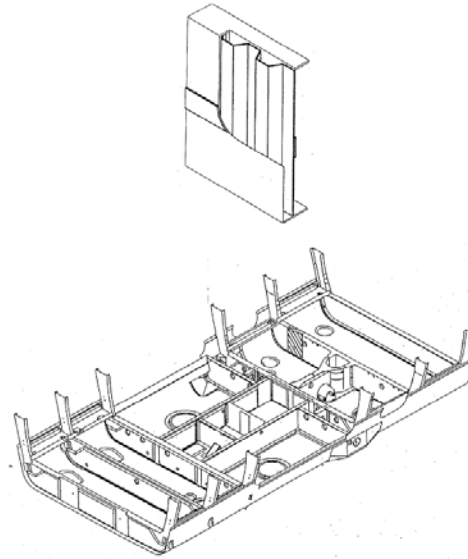

Fig.9: NH90 composite subfloor group with specific energy absorbing design features.

The following substantiation approach (analysis supported by test evidence) has been applied:

The influence of above mentioned structural characteristics was investigated using first the simulation tool KRASH. The design and substantiation of the fuselage structure was done using simulation results. Additionally for the centre fuselage section a detailed sophisticated DYTRAN model was developed. Those simulation tools allowed to select a fuselage design which ensured occupant survivability with respect to accelerations, heavy mass retention and enough survivable volume (see Figures.10 and 11).

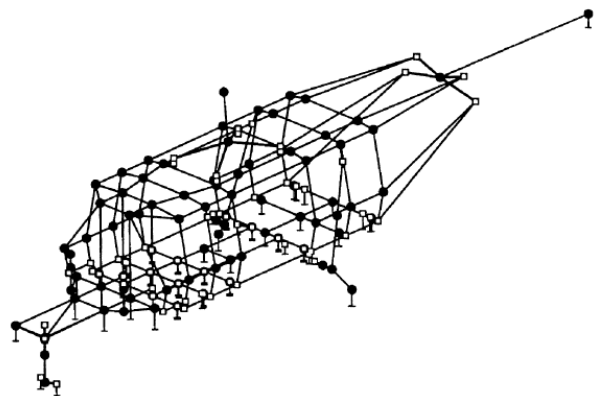

Fig.10: 3D KRASH model of NH90

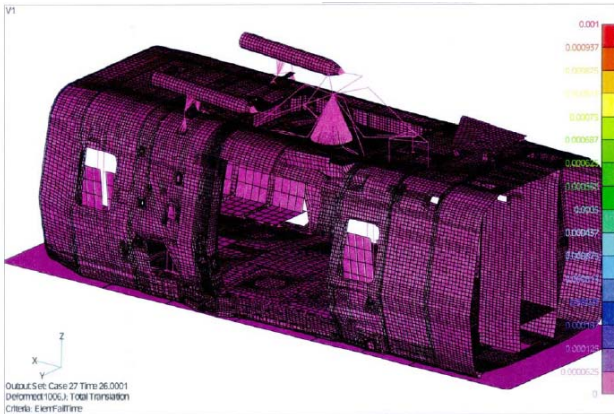

Fig.11: DYTRAN model of NH90 centre fuselage

The analytical (simulation) approach was supported by a so-called “Building Block Approach” (see Fig.12), to provide the necessary input data for the simulation tools as well as to validate finally the crash substantiation for the complete H/C.

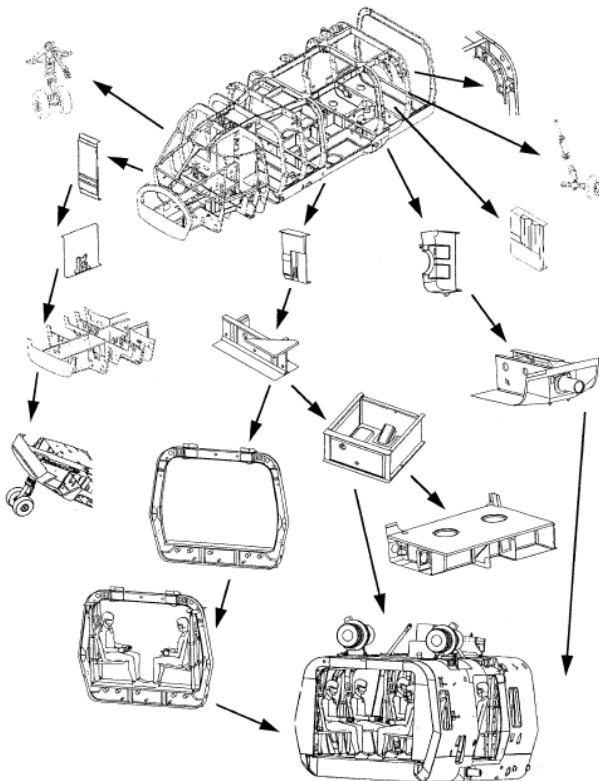

Fig.12: Building block approach for NH90 composite fuselage.

The largest component tested during the development has been a full scale drop test with a fully equipped centre fuselage.

This drop test was conducted at AIRBUS HELICOPTERS Deutschland GmbH premises on 24th Oct. 2002.

The centre fuselage test article included the fuel system (filled with water), all heavy masses, like e.g. main gear box incl. rotor mass and engines masses, etc.. It was equipped with 14 crashworthy seats and 13 anthropomorphic dummies (Hybrid II), (see Figs. 13 and 14).

- The drop test was performed with a vertical impact velocity of ~ 8 m/s.
- 250 measurement channels were used (strains, displacements, accelerations).
- 12 high speed cameras were used.

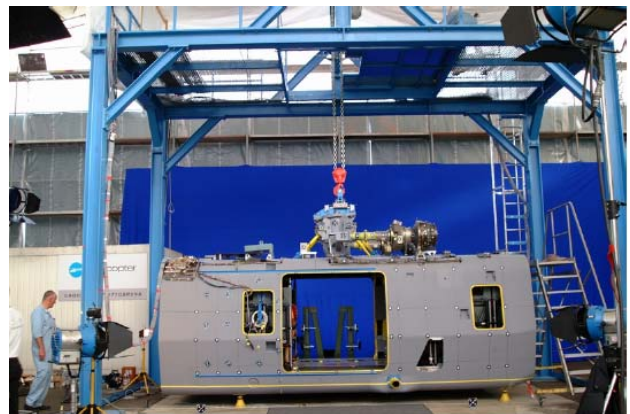

Fig.13: Centre fuselage crash test article, fully equipped, in test rig



Fig.14: Centre fuselage crash test article, fully equipped, front view.

After the test the following was recorded:

- The centre fuselage maintained its integrity. The cabin volume was almost not reduced (much less than 15%).
- All heavy masses remained in place.
- There was no leakage of the fuel system.
- The subfloor group provided sufficient energy absorption to achieve well survivable g-loads for occupants on crashworthy seats (see Fig. 15).



Fig.15: Energy absorption zones at SFG, picture taken after test.

The test results have proven that the crash requirements posed on the fuselage could be met, thanks to the specific characteristics which had been implemented in the design of the composite airframe structure and which were gained to a large extent through the previous BK117 Composite Airframe Program.

5. AIRBUS HELICOPTERS FUTURE AIRFRAMES

Internal experience from research projects and realized serial designs, analysis of accidents and analysis of external studies (e.g. Ref.3) have resulted in an AIRBUS HELICOPTERS-internal approach to design future commercial transport helicopters for a defined level of crashworthiness as a system requirement.

Already existing crash-related requirements for

airworthiness are complemented to a system approach in order to finally get an optimized design with respect to safety, weight and costs.

For the airframe the most significant crash condition is the vertical impact on ground.

Based on the considerations above, as target velocity for a pure vertical crash, a value of approximately 8m/s (covers ~95% of survivable rotorcraft accidents) is taken into account.

In this condition it has to be ensured that the structural integrity of the cockpit and cabin is maintained, that the heavy masses on the upper deck remain attached, that the fuel system remains tight and that the level of accelerations on the cockpit and cabin floor enables occupants to survive on crashworthy seats.

During the definition of the airframe the different elements have to be designed in a way that they all work in a crash scenario as expected.

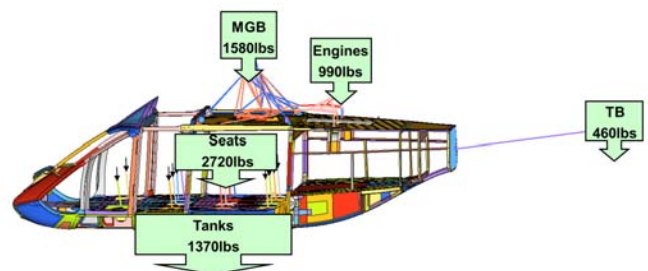

Fig. 16: Mass distribution of helicopter in crash

To transfer the global requirements into a corresponding design analytical simulation methods are used during the development process. Where necessary additional local tests could be performed to support or verify simulation results.

Generally the application of composite structure for airframe is in many cases very promising with respect to lightweight design. On the other hand the specific characteristics of the material itself result in higher analytical effort compared to conventional structures.

The tools and methods for simulation of dynamic impact behavior have been developed and improved significantly during the last years.

On the tool-side today's state-of-the-art Finite Element tools (e.g. RADIOSS) are suitable and capable to do very sophisticated detailed studies.

Appropriate models for dynamic material characteristics have been developed also the last years.

This dynamic impact simulation enables to calculate the internal load distribution during an impact taking

into account also failure modes like laminate strength, global and local instabilities as well as energy absorption by stroking parts of the structure.

The tools have been verified for this application by comparison of simulation results with test results (see Fig. 17, 18, 19 and 20).

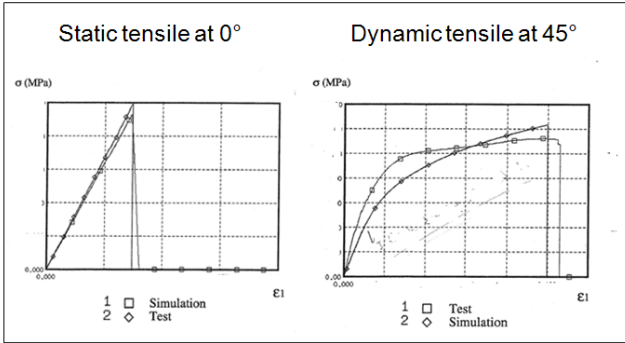

Fig. 17: Verification of simulation approach on coupon level: Fibre and matrix dominated failure modes

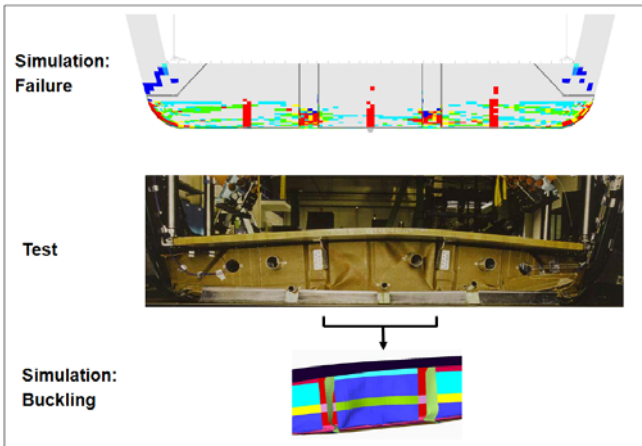

Fig. 18: Verification of simulation approach on sub-component level: Ply failure and local buckling

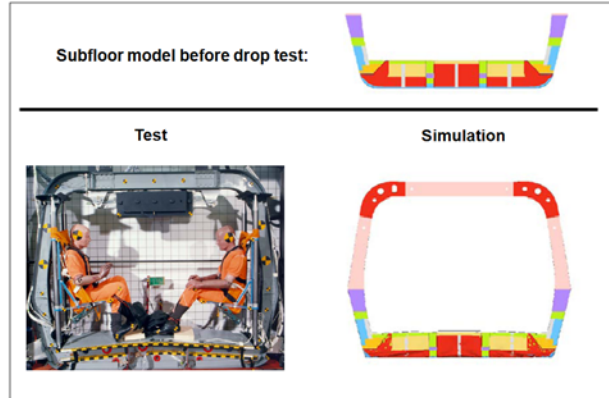

Fig. 19: Verification of simulation approach on component level: Correct local failure and global behaviour

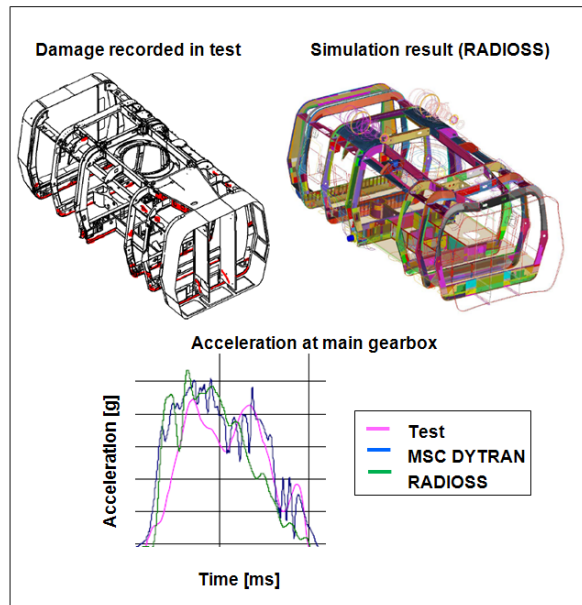

Fig. 20: Verification of simulation approach on full scale level: Damage locations and MGB accelerations

Using the above described simulation means, it is possible today to study the crash behavior analytically and to support the definition of an optimized airframe as part of the complete H/C system. In figure 21 such an airframe simulation model is shown.

In figure 22 an example for the results of a dynamic impact simulation is presented. It shows that the subfloor structure is stroking and so absorbing energy whereas the rest of the airframe does not show significant deformation..

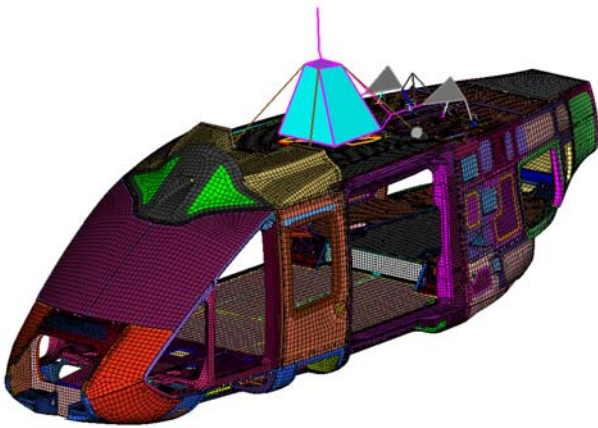

Fig. 21: Crash model of helicopter

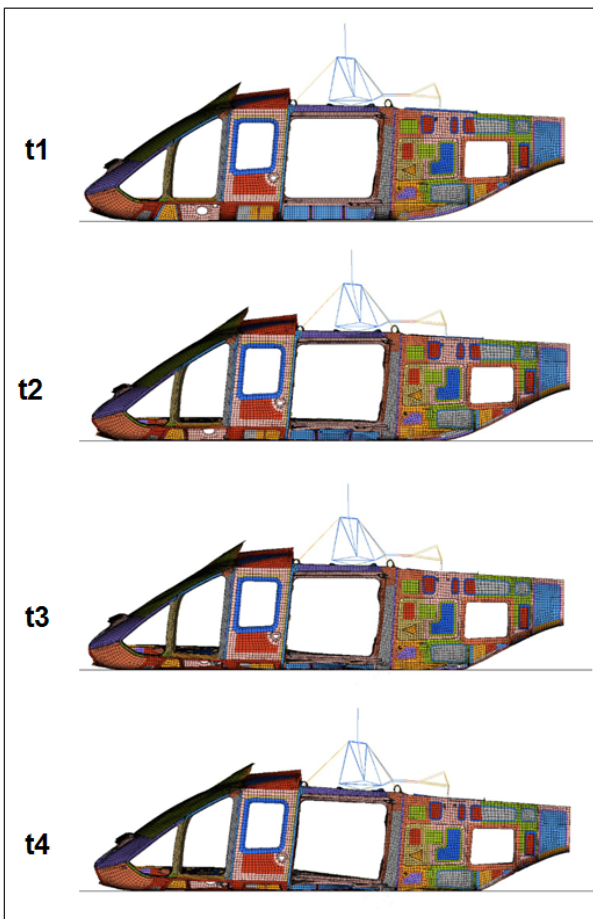

Fig. 22: Crash simulation

6. CONCLUSION

Based on previous experience with research programs and serial rotorcraft, as well as analysis of accidents, it is proposed to take into account a system approach for crashworthiness during the development process, to achieve an optimized compromise between safety, weight and costs.

For future airframes for commercial transport helicopters, the most important design targets have been found as follows:

- ~8m/s vertical impact velocity (covers ~95% of survivable rotorcraft accidents) should be assumed.
- structural integrity, high-mass retention and fuel system leak tightness have to be maintained.
- additionally, occupant survivability has to be ensured by means of crashworthy seats and a sustainable level of acceleration at their mounts

7. REFERENCES

- (1) EASA CS-29 "CERTIFICATION SPECIFICATIONS FOR LARGE ROTORCRAFT"
- (2) FAA FAR Part 29 "AIRWORTHINESS STANDARDS: TRANSPORT CATEGORY ROTORCRAFT"
- (3) „ROTORCRAFT CRASHWORTHY AIRFRAMES & FUEL SYSTEMS TECHNOLOGY“
Rep.No. DOT/FAA/CT-91/7
- (4) Kindervater, Ch., Gietl A., Müller R. "CRASH INVESTIGATION WITH SUB-COMPONENTS OF A HELICOPTER LOWER AIRFRAME STRUCTURE", 66th AGARD-Structures and Materials Panel, Specialists Meeting, Luxembourg, 2-4 May 1988.
- (5) Nitschke, D.R.H., Müller, R. "THE SYSTEM APPROACH TO CRASHWORTHINESS FOR THE NH90", 51st AHS Annual Forum 1995