

# VIRTUAL COCKPIT INSTRUMENTATION USING HELMET MOUNTED DISPLAY TECHNOLOGY

Thomas Lueken, J. M. Ernst, H.-U. Doehler  
German Aerospace Center (DLR), Institute of Flight Guidance, Braunschweig, Germany

## Abstract

DLR's Institute of Flight Guidance has developed a new concept for virtual cockpit instrumentation based on a monochrome green "looking-through" helmet mounted display system (JedEye™). The resolution of the helmet is more than HD-TV, good enough to show detailed information as on presently installed head-down instruments. In addition to our latest 3D helicopter landing symbology, basic virtual instruments like Primary Flight Display, Navigation Display, and knee-board have been implemented in the near field of the cockpit environment in "no-window" areas. Pilots perceive these display elements as if they were located within the cockpit structure at a fixed and stable location in space. Besides, we have realized a "drag and drop" mechanism, which enables pilots to interactively arrange instrumentation on their personal preference by moving the display to another location, and additionally to adapt the display size. To prevent the pilot from dealing with too many different buttons, the interface comprises only three push buttons, which can easily be configured to be driven by already existing buttons on collective or center stick. The employment of only three push buttons and the pilot's head movements tries to make the mechanism intuitive and straightforward. First pilots' feedback show, our concept offers a great potential to be introduced into the future flight deck.

This paper describes the implementation of both the helmet based virtual cockpit instrumentation in combination with a visual-conformal landing display format and the HMI concept with the usage of a high sophisticated helmet mounted display system.

## 1. INTRODUCTION

Today, many types of fixed-wing aircraft are equipped with head-up displays (HUDs). These consist of a graphics computer, a projection device, and a semi-transparent mirror: the so-called combiner located behind the cockpit window and within the pilot's field of view. HUDs are fixed to the aircraft structure and can graphically visualize flight status data as well as visual-conformal elements, such as the flight path vector in space, or the expected runway borders. The field of view usually ranges from 25 x 20 up to 40 x 30 degree. These systems offer a monochrome (mostly green) display, and multi-color systems are in development<sup>[1],[2],[3]</sup>.

A helmet-mounted display (HMD) overcomes the reduced field of view of aircraft-fixed HUDs. Together with a tracker, which measures the head's orientation, a graphics computer generates images that are aligned to the outside world<sup>[1]-[4]</sup>. Various HMDs have been used on military platforms during the last decades. One famous example is the Joint Helmet-Mounted Cueing System (JHMCS) developed by Vision Systems International, which is used in many fighter aircraft, for example in the F-22 Raptor of the U.S. Air Force (Figure 1)). It enables head-slaved targeting but also improves situational

awareness by providing additional flight and aircraft status information<sup>[5]</sup>. Furthermore, not only fixed-wing aircraft but also helicopter pilots wear helmet-mounted systems. The crew on the AH-64 Apache helicopter, for instance, uses the monocular Integrated Helmet and Display Sight System (IHADSS) for weapon-aiming and monitoring of the surroundings augmented by Forward-Looking InfraRed (FLIR) images that are captured by the head-steered camera on the nose of the helicopter<sup>[6]</sup>. This system developed by Elbit Systems Ltd. is depicted in Figure 2).



**Figure 1: Vision Systems International Joint Helmet-Mounted Cueing System (JHMCS) for Fixed-Wing Fighter Aircraft**



**Figure 2: Elbit Systems Integrated Helmet and Display Sight System (IHADSS) for Military Helicopters.**

Beside these introduced quite expensive military systems, there is presently an ongoing development of “low budget” head-mounted displays in the consumer electronics industry. The Google Glass<sup>[7]</sup> can be regarded as one example (Figure 3). Up to now, the Google Glass has no built-in head tracker, and the field of view of this display is rather small, but there are other products just entering the market or being announced, like the Microsoft HoloLens<sup>[8]</sup>. The Oculus VR<sup>[9]</sup> display, applying a medium resolution smart phone display (1920 x 1080 pixel) behind two simple plastic lenses, is another prominent example of this development. The Oculus VR display includes a quite accurate head tracker with a high update rate together with a small delay of the measured angles. However, this display has no looking-through feature since it is mainly developed to extend the virtual reality presentation of PC games, where a view of the real world is not wanted. But together with a simple add-on, i.e. a camera which has to be stiffly mounted and aligned onto the display casing, a very low cost “virtual” looking-through device can be constructed.



**Figure 3: The Google Glass (source Wikipedia)<sup>[7]</sup>**

We purchased a prototype of the Oculus device which is sold as so-called development-kit (DK 2). Together with a simple Logitech conference webcam (resolution 1280 x 720 pixel, field of view 78 degree) we apply this system for testing and concept demonstration purpose (Figure 4).



**Figure 4: Low cost display demonstrator Oculus DK 2 coupled with a Logitech camera (B910) for simulating “looking -through” capability.**

Beside this low-cost display demonstrator we operate a highly sophisticated display device, the so-called JedEye™ HMD system by Elbit Systems Ltd. (Table 1, Figure 5). This display was installed into our Generic Cockpit Simulator (GECO, Figure 6) as well as into our research helicopter ACT/FHS (Active Control Technology / Flying Helicopter Simulator). The ACT/FHS “Flying Helicopter Simulator” of the German Aerospace is based on a standard Eurocopter EC 135 type helicopter, which has been extensively modified for use as a research and test aircraft.

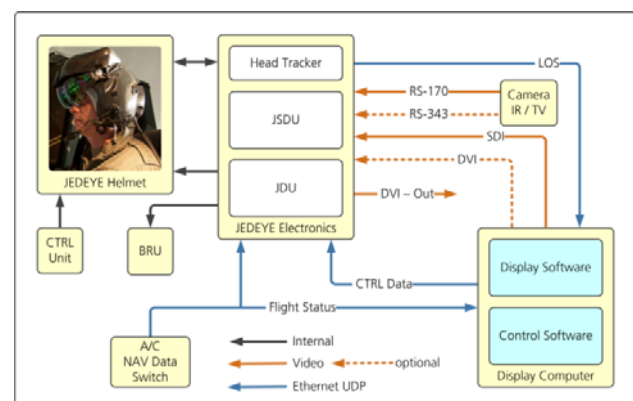

**Figure 5: Main hardware components and interfaces of the JEDEYE helmet-mounted display (HMD). JSDU: JEDEYE system display unit. JDU: JEDEYE display unit. LOS: Line of sight. SDI: Serial digital interface (for video transmission). DVI: Digital video interface. BRU: Bore sight reference unit, an optical**

device for helmet alignment within the helicopter.

Display	optical see-through binocular
Color	monochrome green
Resolution (per Eye)	1920 x 1200 pixel
Field of View (per Eye)	80 x 40 degree
Framerate	60 Hz
Head Tracker	magnetic 400 Hz
Head Tracker Resolution	0.05 degree
Head Tracker Accuracy	0.25 degree
Weight (incl. Helmet Shell)	ca. 2.3 kg
Video-Interfaces	RS-170, SDI, DVI-D, HDMI
Built-in Symbology	JEDEYE-DLR format
Helmet shell	HISL Alpha 900

**Table 1: Main specifications of the JEDEYE HMD system.**

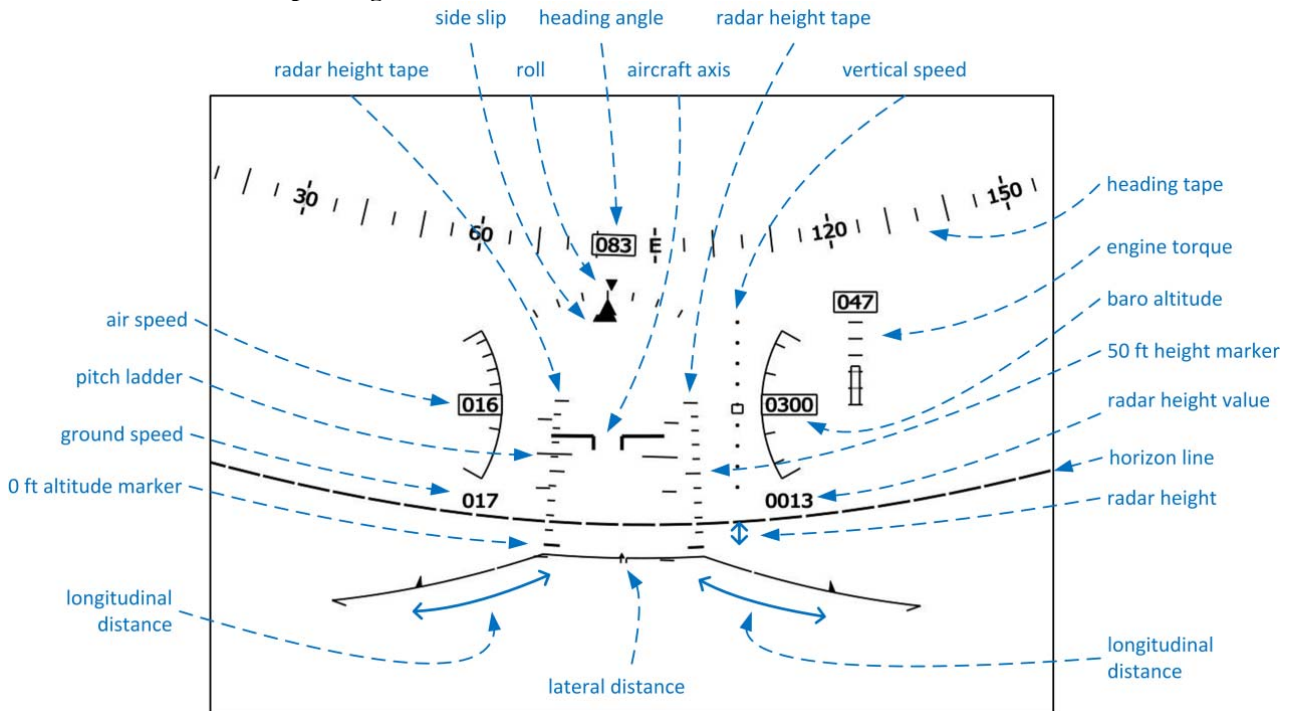

**Figure 6: JedEye HMD integrated into Generic Cockpit Simulator GECO together with cyclic and collective sticks for helicopter flight simulation.**

## 2. VISUAL-CONFORMAL DISPLAY

As simulation trials showed, former 2D HMD formats for helicopter application (e.g. the BOSS display<sup>[10]</sup>) have to be translated into a more intuitive understandable visualization of the helicopter's flight situation and its environment. Pilots can easier accept new types of displays on their helmets, when they are provided with perspective virtual 3D depiction of the environment and the situation of their helicopter. On the one hand side, our goal is to show as much information as possible in visual-conformal manner. On the other hand, it might be contra-productive to overlay too much virtual data onto the visual channel, because reduced visual transparency will also reduce the visual regard to the real world behind. Consequently, a good trade-off between "needed information" and "display clutter" has to be developed step by step and has to be evaluated within simulation trials and/or real flight-testing.

During the last two years we developed some new visual-conformal display formats for the JedEye display, which we investigated and evaluated during intensive simulation tests together with experienced helicopter pilots. As results of these tests within our GECO simulator showed, visual-conformal display formats are easy to interpret and can help helicopter operation to reach a higher level of safety together with a lower level of workload for the pilots<sup>[11]</sup>.



**Figure 7: Proposal of a visual-conformal 3D perspective landing display from DLR<sup>[11]</sup>.**



### 3. VIRTUAL AIRCRAFT-FIXED INSTRUMENTS

Within the following chapter we describe our concept for generating what we call virtual “aircraft-fixed cockpit instruments” (AFCI) and give three examples of implemented formats:

- primary flight display (PFD),
- navigation display (ND), and
- digital kneeboard (DKB).

#### 3.1. Coordinate Systems

Since display designers want to specify the display elements in local display coordinates but the JedEye system renders everything in screen coordinates, one needs to define different frames of reference and the corresponding coordinate transformations. This section introduces these frames and coordinates used for the AFCI implementation.

First, based on the desired instrument position and size, each point of the local display has to be located within the aircraft-fixed frame of reference. Second, the transformed points are rotated to the head-fixed frame of reference, which moves with the pilot's line-of-sight (LOS), before they are finally projected onto the screen of the JeyeEye helmet.

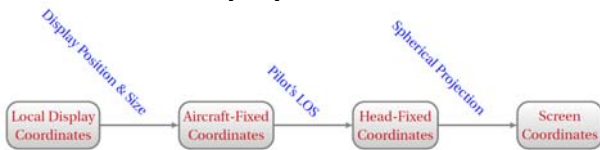

**Figure 8. Transformation chain from local display coordinates to screen coordinates (LOS: line of sight)**

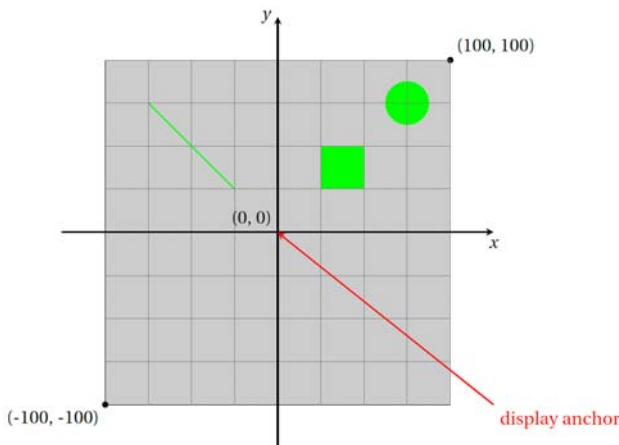

**Figure 9. Definition of local display coordinates**

Every instrument has its own local frame of reference with its origin in the middle of the display area. This gives the display designer the ability to specify the display elements in two-dimensional Cartesian coordinates, called the local display

coordinates (x, y). The origin is referred to as the display anchor and is used to assign a global aircraft-fixed position to the instrument.

As illustrated in Figure 9, the x- and y-coordinates of all virtual instruments range between -100 and 100. The main reason for using this coordinate system is to offer an easy way of designing new displays. The user can specify all display elements as he does it for normal displays in 2D rectangular coordinates. He does not have to care about the transformation from the local display to the screen coordinates, which is carried out in the background.

For a display to be positioned in space, one needs to define a global three-dimensional frame of reference, which is fixed to the aircraft and does not move with the rotation of the pilot's head. As shown in Figure 10, the pilot's eye is in the center of the frame and the Y-axis points towards the nose of the aircraft while the Z-axis is oriented upwards. The AFCI implementation employs two different sets of aircraft-fixed coordinates: Cartesian coordinates (X,Y,Z) as well as spherical coordinates (R,ψ,θ), where R is the radius, ψ is the azimuth and θ is the elevation angle.

The conversion between Cartesian and spherical coordinates is given by

$$\begin{aligned}
 X &= R \cos \theta \sin \psi \\
 Y &= R \cos \theta \cos \psi \\
 Z &= R \sin \theta
 \end{aligned}
 \tag{1}$$

and

$$\begin{aligned}
 R &= \sqrt{X^2 + Y^2 + Z^2} \\
 \psi &= \arctan(Y / X) \\
 \theta &= \arcsin(Z / R)
 \end{aligned}
 \tag{2}$$

respectively.

In order to get the screen coordinates (azi<sub>A</sub>, ele<sub>A</sub>), the 3-D point A has to be mapped to the 2-D spherical screen surface. This projection is illustrated by the dashed green line and the resulting point A<sub>S</sub> on the screen in Figure 11. As can be seen easily, the screen coordinates (azi<sub>A</sub>, ele<sub>A</sub>), in which the JedEye system renders the graphics, are equal to the spherical head-fixed coordinates of point A. Therefore, the projection is basically a transformation from Cartesian to spherical head-fixed coordinates (see equation (2)).

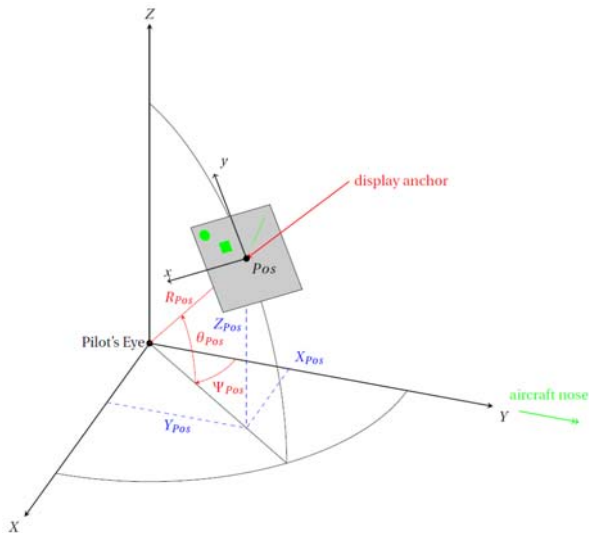

**Figure 10: Definition of two sets of aircraft-fixed coordinates**

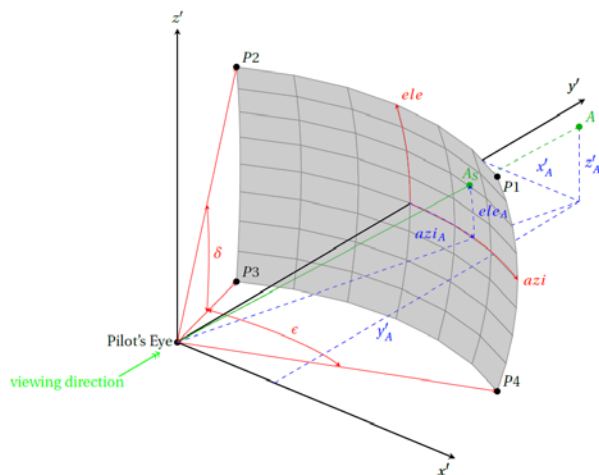

**Figure 11: Head-fixed and screen-coordinates**

### 3.2. Implemented display types

#### 3.2.1. Primary Flight Display - PFD

The PFD (Figure 12) is a combination of flight instruments which were formerly included in the cockpit as separate mechanical gauges. The layout of the display varies from aircraft to aircraft but the basic design is still inspired by the old analog instruments. Based on that, the implemented PFD is divided into five segments: Attitude indicator, airspeed tape, heading tape, vertical speed indicator and altitude tape. Each segment is represented by its own function, which performs all computations needed for displaying this part of the display. Within our implementation, the whole geometry is connected to an element origin that allows easy repositioning of this segment within the PFD frame of reference. The applied design is mainly based on

the basic instrumentation of our EC135 helicopter. It consists of the following elements:

- center: pitch ladder (1), roll scale (2), roll angle (3), side slip (4), aircraft axis (5), radio height (6), decision height flag (7)
- left: airspeed tape on left side, digital airspeed (8), airspeed trend (9), groundspeed (10), speed setting (11)
- bottom: heading tape (13), digital heading (12), heading set (14)
- right: vertical speed (15), feet-per-minute (16), digital altitude MSL (17), altitude tape (18), altitude set (19), terrain altitude (20), barometric pressure setting (21)

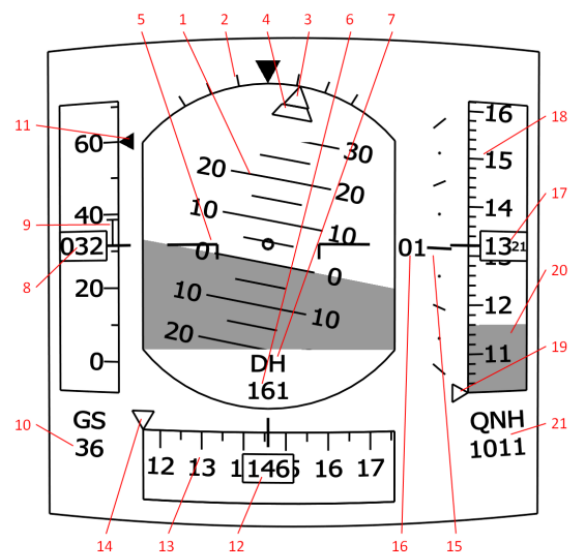

**Figure 12: Implemented PFD and ...**

#### 3.2.2. Navigation Display – ND

The ND (Figure 13) as the second main display besides the PFD provides the pilot with information that is used to navigate the aircraft. It shows a top view of the current situation around a fixed aircraft symbol (1) in the center. The instrument is implemented in the so-called ARC mode, which means that a forward-oriented arc of the compass rose is displayed around the aircraft. One can read the current heading as well as the target heading from the compass scale (2) and the connected marker (3). Moreover, the display is capable of presenting a desired route (4) with its waypoints (5). By zooming in or out, the pilot can adjust the scale and the range of the “map”, which is represented by the stippled arc and the connected value (6).

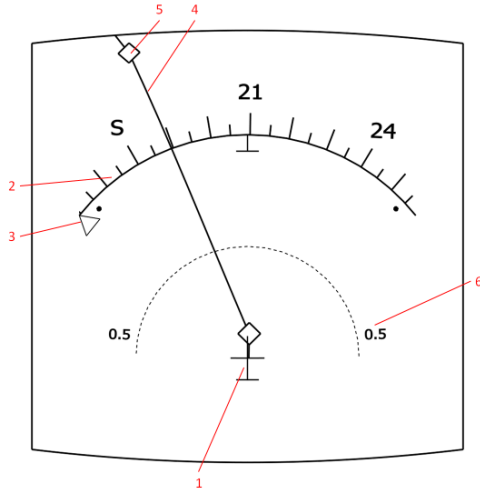

Figure 13: ... ND format, based on the existing EC135 display layout

**3.2.3. Digital kneeboard – DKB**

The third element of our AFCl implementation is not a conventional display but the digitization of an accessory used by pilots: the digital kneeboard (DKB, Figure 14). A conventional kneeboard is capable of holding various paper charts, check-lists etc., and therefore gives the pilot the ability to have important information, such as approach charts, close by. Since maps, charts, text-files are produced digitally, it is an obvious idea to display these information directly on the HMD. This enables pilots to freely place their kneeboard in the virtual cockpit. They can even have a set of different kneeboards in various locations around them, for example above the cockpit windows.

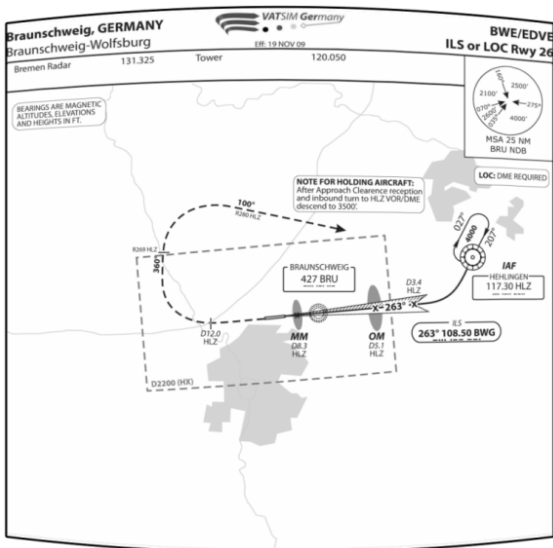

Figure 14: Digital kneeboard with an exemplary approach chart of airport Braunschweig-Wolfsburg

**3.2.4. Interaction – Drag & Drop Mechanism**

A supplemental feature of our AFCl implementation is the drag & drop mechanism. It enables the user to interactively move the displays to another location, and additionally to adapt the display size. To prevent the pilot from dealing with too many different buttons, the interface comprises only three push buttons, which can easily be configured to be driven by already existing buttons on collective or center stick. The employment of only three push buttons and the pilot’s head movements tries to make the mechanism intuitive and straightforward.

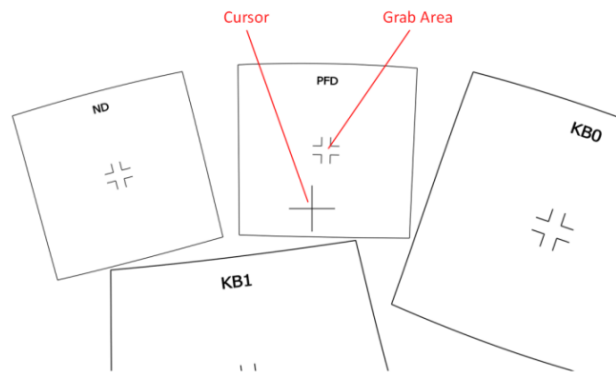

Figure 15: Schematic displays during activated drag & drop mode – cursor and grab area.

There are the following three buttons:

- BUT\_1 – activate/deactivate/grab/drop
- BUT\_2 – zoom in
- BUT\_3 – zoom out

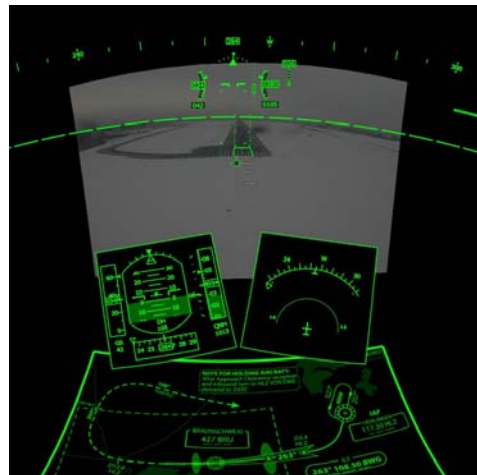

Figure 16: Approach to RWY-26 on Airport Braunschweig-Wolfsburg. PFD (left), ND (right) and digital kneeboard (bottom) above the visual conformal 3D landing display. An on-board recorded TV image is visualized behind the green JedEye graphics. Flight data have been recorded during EC135 flight trials.

When BUT\_1 is pressed, the frames of all AFCI are turning into drag & drop mode (Figure 15). When BUT\_1 is pressed again drag & drop mode is deactivated. Within drag & drop mode a cross-cursor is shown within the viewing center. While moving their head, pilots can move this cursor around. Whenever the cursor-cross is located within the grab area of a display, a second BUT\_1 push glues the respective display to the cursor and the pilot can move that display element. Via the next BUT\_1 push the display is dropped at the present location and drag & drop mode is deactivated. While a display is activated the BUT\_2 and/or BUT3 can be used for resizing the display (zoom-in, zoom-out). When during activated drag & drop mode a fetched display is moved above the grab area of another display, then the positions of both displays are exchanged.

#### 4. PILOTS FEEDBACK

We applied our GECO simulator with the integrated JedEye AFCI-display so as to present our concept to helicopter pilots and ask them about their feedback. We prepared a questionnaire to acquire pilots' evaluation and comments. Up to now we gathered the feedback from two helicopter pilots from our DLR flight department, only. These were two rather experienced colleagues, trained on flying various helicopter types including our EC135 Flying Helicopter Simulator (FHS), which is prepared for conducting in-flight tests with the JedEye HMD. One of our pilots had some in-flight experiences with the helmet display, but not with the present implementation of the AFCI symbology. The other pilot, normally working as "safety pilot" on the FHS, has no in-flight experiences with the JedEye helmet. Both pilots were involved in our simulation study<sup>[11]</sup> in 2014, where they gained experiences with the JedEye display system itself. For our study, the pilots were instructed to test the AFCI concept and its usability, in general.

##### 4.1. Pilots' evaluation

We fed recorded real flight-data into our simulator. Our pilots were given the "pilot non-flying role", so that they were able to play around with the display, without being distracted by helicopter control. Besides, we asked the pilots to compare the AFCI presentation (together with the same replay data) on the JedEye with the presentation on the Oculus DK2 prototype. In contrast to the JedEye visualization, the Oculus implementation incorporated some visual depth difference between the AFCI instruments and the HMD-symbology behind.

We applied an evaluation scale with five levels (Table 2).

very bad	bad	neutral	good	very good
--	-	0	+	++

**Table 2. Quality scale applied for general evaluation**

The following table summarizes the results of our questionnaire.

idea and overall concept	+
interaction concept	+
user definable location of different display elements	+
location around the pilot's head	++
PFD format	0
ND format	0
digital kneeboard	++
readability	0
contrast / brightness	+
smoothness	+

**Table 3. General feedback concerning concept and implementation**

From the pilots' perspective the concept is able to enhance the present, state-of-the-art helmet displays. Especially the electronic kneeboard is appreciated and has the potential to evolve into a new information channel. Our pilots preferred a size of the PFD and ND between 10 x 10 and 12 x 12 degree.

As the comparison between Oculus and JedEye showed, the present display resolution of the Oculus prototype remains far behind the JedEye quality. The field of view of the Oculus appears to be much smaller. Its display sharpness (from its simple single lens optic) is recognized to be very bad at the field of view's border. In general, both pilots reported that Oculus appeared to be exhausting after some minutes of wearing. Although the smoothness of the Oculus implementation does not show any drawbacks, the artificially introduced visual depth perception between the foreground instruments and the HMD graphics behind was not appreciated by one pilot, while the other one evaluated the stereo depth separation quite positive.

##### 4.2. Pilots' suggestions

- Both pilots required a "hide" button for the AFCI. During the final landing phase, pilots want to see

the outside situation without any disturbing overlaid symbology. The proposed hide button should be implemented as a display toggle function.

- Both pilots were a bit confused by the orientation of neighboring instruments, which appear tilted against each other. Although this is an intended behavior, there is probably some incompatibility between display concept and visual experience, especially when people are trained to look on horizontally aligned panel-displays.
- Both pilots criticized the presently needed positional head movement accuracy for the handling of the drag and drop mechanism. Due to the expected vibration level within the real helicopter, a more robust concept for display grabbing should be implemented, for example by applying the whole instrument area for grabbing.
- The appreciated digital kneeboard implementation should be enhanced with an electronic on-board library of electronic documents. The access to single document pages should be implemented as “quick browsing through” mechanism.
- One pilot required an additional, simple “in-flight” contrast and brightness control, especially for the additional AFCl instruments.
- Finally, both pilots would appreciate an extension of the display concept with a speech control mechanism.

## 5. CONCLUSION AND OUTLOOK

We have presented some new design ideas for high resolution helmet- and/or head-mounted display formats. Our concept combines visual-conformal perspective elements which are shown as overlay onto the outside vision (tunnel, waypoints, landing pad, and other flight guidance data), with several virtual head-down display surfaces, which we call virtual aircraft-fixed instruments (AFCl). Pilots perceive these display elements as if they were located within the cockpit structure at a fixed and stable location in space. Real head-down displays are expensive, need some rigid mounted structure behind, and therefore are restricted with regard to the optimal orientation relative to the pilot's eye. Our display overcomes these disadvantages. Their surfaces can be located freely in space and can be mounted with optimal orientation, i.e. their normal vector is pointing to the pilot's eye.

Our approach includes some simple “three-button” concept for interaction, so that pilots can re-locate,

re-arrange, and re-size the instruments. As first minor comments from helicopter pilots show, there has to be carried out some additional improvements regarding the overall operability, without increasing pilot's workload.

The presently ongoing worldwide development of low cost head-worn displays will probably spread out and influence the avionic equipment in the future. It is imaginable that one day even the view through the cockpit window will be virtualized. Then outside the fuselage mounted camera arrays will capture a totally unblocked 360 x 180 degree view onto the outside world. These data will then be sent to the head-worn displays of the pilots and probably to the displays of the passengers as well. Expensive and heavy cockpit windows will become obsolete and maybe, even the present cockpit location within the aircraft nose will be no longer required. This will enter more freedom for aircraft design, like some RPAS (remotely piloted aircraft systems) developments (aircraft without cockpit) already show today.

## ACKNOWLEDGEMENTS

This work was partly sponsored by the German Department of Defense (DOD) within the following projects:

- Increase of all-weather capability by developing a flight management system in connection with the use of a helmet mounted display (HMD).
- ALL-In-Flight - Assisted Low Level Flight using In-Flight Simulation capability.
- Integrated on-board flight guidance – navigation, sensors and MMI

We would like to express our thanks to Elbit Ltd., Israel for providing installation and integration support for the JedEye™ HMD.



## REFERENCES

- [1] J. E. Melzer, F. T. Brozoski, T. R. Letowski, T. H. Harding, and C. E. Rash, *Helmet-Mounted Displays: Sensation, Perception, and Cognition Issues*, pp. 805–848, US Army Aeromed. Res. Lab., Fort Rucker, AL, 2009.
- [2] C. Rash, W. McLean, J. C. Mora, M. H. Ledford, B. T. Mozo, J. R. Licina, and B. J. McEntire, *Design Issues for Helmet-Mounted Display Systems for Rotary-Wing Aviation*, US Army Aeromedical Research Laboratory, Fort Rucker, AL, 1998.
- [3] M. Velger, *Helmet-Mounted Displays and Sights*, Artech House, 1998.
- [4] J. E. Melzer, *Head-Mounted Displays*. In *The Avionics Handbook*, C. R. Spitzer, Ed. CRC, Press, Boca Raton, 2001.
- [5] Vision Systems International, JHMCS, [http://www.vsi-hmcs.com/pages\\_hmcs/02\\_jhm.html](http://www.vsi-hmcs.com/pages_hmcs/02_jhm.html), 19.01.2015.
- [6] Elbit Systems, IHADSS. <http://www.elbitsystems-us.com/airborne-solutions/products-sub-systems/helmet-mounted-systems/helicopter-helmets/ihadss> 19.01.2015.
- [7] -, Google Glass, [http://en.wikipedia.org/wiki/Google\\_Glass](http://en.wikipedia.org/wiki/Google_Glass), 19.01.2015.
- [8] -, Microsoft HoloLens, <http://www.cnet.com/news/microsofts-hololens-is-no-joke-my-reality-augmented-with-skype-minecraft/>, 20.01.2015
- [9] -, Oculus VR, <https://www.oculus.com>, 19.01.2015.
- [10] Z. Szoboszlay et al., *Pilot Briefing Package on BOSS Symbology*, 2010.
- [11] H.-U. Doehler, Sven Schmerwitz, Thomas Lueken, "Visual-conformal display format for helicopter guidance", *Proc. SPIE 9087, Degraded Visual Environments: Enhanced, Synthetic, and External Vision Solutions 2014*, 90870J (June 19, 2014); doi:10.1117/12.2052677, 2014.