

FOURTEENTH EUROPEAN ROTORCRAFT FORUM

Paper No 82

NEW SYSTEMS FOR HELICOPTER AND AIRCRAFT VIBRATION MONITORING

RICHARD C MUNDEN

STEWART HUGHES LIMITED
SOUTHAMPTON HAMPSHIRE UNITED KINGDOM

20-23 September 1988
MILANO, ITALY

ASSOCIAZIONE INDUSTRIE AEROSPAZIALI
ASSOCIAZIONE ITALIANA DI AERONAUTICA ED ASTRONAUTICA

ABSTRACT

Vibration monitoring techniques and equipments cover a wide range of capabilities. These options will be reviewed in terms of their technical difficulty and benefit to the user.

The paper will range from the lowest cost "Measure and Tell" capability of vibration monitoring to the fully automated track and balance equipments. Actual experience will be included.

The extension to a fully interactive maintenance capability, which is under development, will be discussed.

1.0 INTRODUCTION

Airborne vibration monitoring currently relies on the ability of the pilot to detect abnormal vibrations. When a vibration problem is reported maintenance staff have very little information to access the depth or nature of the fault. Installation of a portable ground support equipment is required followed by a specific maintenance test flight to evaluate the reported exceedance. This practice does rely heavily on the pilot to detect abnormal vibration and maintenance staff to react quickly to keep aircraft serviceable.

With the increased efforts to improve safety and reduce ownership costs by lowering maintenance flight time, more helicopter manufacturers and operators are now considering airborne monitoring as part of the on-board instrumentation. However, there is still a strong case for having an effective ground support equipment which can be installed periodically or on demand, and flown on the next revenue or mission flight.

The systems and solutions offered to meet the growing need to monitor vibration should take account of the different helicopter types from the light utility to the medium transport helicopter. Also, the operating conditions that have to be met vary enormously from one operator to the next.

The following equipments discussed have been classified as "Permanent On-board" and "Portable Ground Support". One or more of the following systems described should meet the current and future needs of helicopter operators for vibration monitoring:

Permanent on-board

- 1 Analogue Vibration Monitoring Systems (AVMS)
- 2 Digital Airborne Monitoring Systems (DAMS)
- 3 Health and Usage Monitoring Systems (HUMS)

Portable ground support

- 4 Vibration and Tracking Equipment
- 5 Gearbox Testing System (GTS)

2.0 ANALOGUE VIBRATION MONITORING SYSTEM

The analogue vibration monitoring system has been designed to meet the perceived needs of the light utility helicopter, and as a possible interim solution, before the introduction of a full health and usage monitoring system (HUMS).

The equipment offers the operator a low cost monitoring system which is compact (100mm x 50mm x 75mm) and light (600g).

The analogue vibration monitoring units have up to 8 accelerometer inputs and 2 tachometer channels. Each accelerometer is tuned to a particular specific frequency with an independent threshold/alarm level. When the vibration frequency exceeds a set alarm level for more than a defined period, an electro mechanical indicator will show that an event has occurred. The reason to include a time period before an alarm is triggered is to reduce false alarms caused by vibration spikes.

The analogue vibration monitoring system alone can only give an indication that a problem has occurred, as it is fundamentally a simple monitoring device. To extend the system further the use of a portable ground support system (such as the RADS-AT), with powerful vibration trouble shooting capabilities will give the helicopter operator greater scope for reducing vibration. When an exceedance has occurred the RADS-AT would be installed on the aircraft. On the next revenue or mission flight the RADS-AT would monitor all 8 channels and produce a 400 line spectrum for each channel. This information could be reviewed and diagnostics derived when the aircraft returned from its revenue flight. Data can be transferred to a ground station for further analysis. The addition of a ground station would act as a data base and give operators the ability to trend on each aircraft or across the fleet as well as maintaining accurate maintenance records.

3.0 DIGITAL AIRBORNE MONITORING SYSTEM (DAMS)

The Digital Airborne Monitoring System (DAMS) is a pilot initiated system for the automatic collection of airframe vibration and track data.

The basic system consists of a permanent on-board equipment in the form of a Data Acquisition Unit (DAU) and a Pilot Control Interface (PCI). The data can be down loaded

from the aircraft either by a credit card memory device, or using a data retrieval analysis unit. The automatic blade tracker (ABT) would only be fitted when rotor diagnostics are required. However, it could be permanently fitted.

The system collects data when the pilot initiates the pilot control interface at a set condition, ie cruise speed of 130 knots. The data is automatically collected and stored. It is intended that no-inflight warnings would be given, because the false alarm rate although exceedingly good would not be low enough to give pilots confidence in any alarms generated in-flight. When data is down loaded after a flight the hand held data retrieval and analysis unit will give a probable cause to any high vibration levels and it can be used in the spectrum analyser mode with non-destructive zoom for further analysis of the data. If the data was transferred to a credit card, it then has to be transferred to a ground station on-site or at a central base. The tracker or ABT is only fitted when certain parameters have exceeded their threshold values (one per rev levels). When the aircraft returns from the flight with the tracker fitted, corrective actions can be applied to rotor head, requiring currently a test flight to ensure that the new vibration levels are satisfactory.

The size of the on-board data acquisition unit is 280 mm wide by 53 mm high by 212 mm deep and has a weight of 2.1 Kgs. The pilot interface unit consist of a panel of up to four buttons representing the conditions where data is required to be gathered, and an on/off switch is included on the panel.

4.0 HEALTH AND USAGE MONITORING

Health and Usage Monitoring Systems (HUMS), (Figure 1), are still in their infancy and much development and testing remains before aviation regularity authorities certify them. It is very likely that by 1995 medium transport helicopters in the North Sea will have to have a HUMS unit fitted when carrying passengers. The aims of such a system are to improve safety and ultimately improve maintenance costs by placing components "on-condition" rather than current situation which has components hours rated. An added benefit for maintenance staff is more quantitative information to plan their work on.

The British International Helicopter/CAA trial HUM system will include an on-board main processor unit, which in some aircraft may have addition multiplexer boxes, a hand held retrieval unit, and a ground station. The main processing unit will weigh about 8 Kg. Sensor outputs will, in the main, be fed to multiplexers which in turn will send signals to the main processing unit. The hand held data retrieving unit is used to transfer data from the main processing unit to the ground station. Initial results can be reviewed using the data retrieval unit. The ground station

consists of a personal computer running data base and graphics software.

4.1 System requirements

No single technique is adequate to monitor an individual rotating component, as corroborative evidence of deterioration is often needed. For instance, gearbox vibration monitoring techniques have been successful but vibration monitoring alone cannot always provide an adequate prediction; a complementary technique such as oil debris monitoring can yield a significantly higher probability of fault detection, and reduce false alarm rates.

The system must also be reliable and produce no spurious warnings, sensors must also be robust, servicing requirements must be minimal. It must not hazard the airworthiness of the aircraft or alter the normal flight characteristics. In its production form it must be small, light, have minimum power consumption, and operating costs must be kept low.

The equipment must give long maintenance-free service in a hostile environment so the problems of vibration, operating and temperatures will need to be addressed.

The monitoring provided by a "typical" HUM system could include:

- *Engines*
 - Life and exceedance data
 - Health data
 - High speed shafts
 - Foreign object damage
- *Gearbox*
 - Torque usage
 - Health and condition data
- *Transmission*
 - Tail rotor transmission including bearings
- *Control system monitoring*
- *Automatic inflight tracking*
- *Usage data*
 - Data from flight instrumentation
 - Outside air temperature
 - Weight on wheels

The HUM system on an aircraft could have between 25 to 50 sensors installed, and these will produce a vast amount of data. An effective method of controlling and utilising the data is to use a ground station with interactive graphics and a data base. This is the operators main interface with HUMS and it is very important that it should be carefully implemented and its functions well thought out. The maintenance operator should only be provided with data once an alarm threshold has been exceeded or an event has occurred. Data that has caused alarms to be triggered is indicated to maintenance operators using interactive graphics displays. Figure 3 illustrates an exceedance and the stages an operator can progress to find the components which are faulty and the data that has caused the alarm to be raised. The progression from one stage to the next is achieved by localising a cursor on the flashing part of the screen and pressing a key. The ground station along with the rest of the HUM system is still in its early days, but in the near future it should have some prognostic capability included as well as maintenance/usage scheduling to help aid better maintenance planning and airworthiness.

5.0 GROUND SUPPORT

5.1 Vibration and tracking equipment

With the advance in modern vibration monitoring, tracking and diagnostic equipment, the helicopter operator has more extensive techniques available which can be carried out much faster than the previous equipment. Saving in maintenance flights and time will ultimately help to reduce costs. Added savings that can result from smoother aircraft would be reduced avionic failures. Other benefits that should be associated with lower vibration levels are reduced pilot fatigue and improved passenger comfort.

The rotor analysis system, RADS-AT, consists of 3 basic units, the data acquisition unit (DAU), a control and display unit (CADU) and the automatic blade tracking. The equipment can achieve a 5 condition rotor track and balance flight with asynchronous spectrums, taken less than 10 minutes flight time. Parallel data acquisition is the primary reason for the short flights.

The diagnostics that are available are designed to rectify all main rotor faults such as trim tabs, pitch-links and mass balance (assuming the aircraft design authority allows) in one maintenance action, this is commonly termed as "single shot" technique. The illustration (Figure 2) shows the initial test flight and the following confirming test flight. The last flight is to determine the effect of the "single shot" adjustments. It can be seen that there was a dramatic reduction in the high vibration and track levels, although some of the smaller vibration levels did increase slightly. These results were achieved using an exact

mathematical optimiser to calculate the corrections for the rotor head. The actual adjustments made were 500 grams added to correct the mass imbalance and 2 "flats" on the pitch link for track.

The vibration capability of such a system as the RADS-AT is extensive having 14 vibration channels over 4 asynchronous vibration ranges all with non-destructive zoom. On particular aircraft types a "probable cause" facility is included on the asynchronous vibration spectrum which will assist an operator to find the offending faults.

The type of equipment described can be used on revenue or mission flights without incurring any inputs from the pilot. This can be used to improve maintenance of aircraft by regular vibration checks without incurring any extra maintenance flight time.

A simplified version of the HUMS ground station can be used for data basing, analysis and trending the data. Data transfer can be by either the credit card or CADU.

6.0 GEARBOX TESTING SYSTEM

The requirement for a portable gearbox testing system for helicopters has been identified by NGA 6638 feasibility study and the work Stewart Hughes has carried out with helicopter manufacturers.

The objective of introducing the equipment would be to improve airworthiness and extend time between overhauls (TBO) by the implementation of on-condition maintenance and efficient health monitoring. This should have major benefits in aircraft maintainability and reduced ownership costs, especially for aircraft not fitted with HUMS.

The vibration signature is a time averaged technique for gear analysis and a high frequency resonance technique for rolling element bearings. Using these methods the following faults could be detected:

Gears/Shafts

- Misalignment
- General and serious local damage
- Pitted gear
- Oval annulus gear problems
- Machine instability
- Planet load sharing problem
- Cracked shafts
- Undefined faults

Bearings

- Rolling element
- Outer race faults
- Inner race faults

The system would fundamentally be a single, robust, portable unit which would be connected to a nominated point in the aircraft cabin or cargo area where up to 16 gearbox accelerometers and 4 tachometers were permanently wired. The tests would be carried out at nominated steady state conditions started by a remote unit in the cockpit. In the event of the aircraft not staying on station during the measurement phase the test would have to be restarted. At the end of the tests the exceedances would be logged and an output would indicate the condition of the gearbox with any faults detected. It is anticipated that the data would then be sent to a central data base for fleet records, trending and any further analysis required.

7.0 CONCLUSIONS

The new vibration monitoring systems which are currently available to helicopter operators should allow greater aircraft availability and reduced ownership costs. The future for the more advanced systems such as HUMS, should see a significant improvement in maintenance costs with condition monitoring and a corresponding increase in safety standards.

8.0 REFERENCES

- [1] P J Goodchild, 'Modular HUMS system', Fourteenth European Rotorcraft Forum 1988
- [2] P Gadd, 'The capability of built in equipment for VA (Vibration Analysis) monitoring of military helicopters', Naval Aircraft Materials Laboratory, Gosport, England. Condition Monitoring '87. Proceedings of an International Conference on Condition Monitoring held at University College, Swansea
- [3] R M Stewart, 'Advanced transmission system health monitoring (Surface space technology)', Thirteenth European Rotorcraft Forum 1987

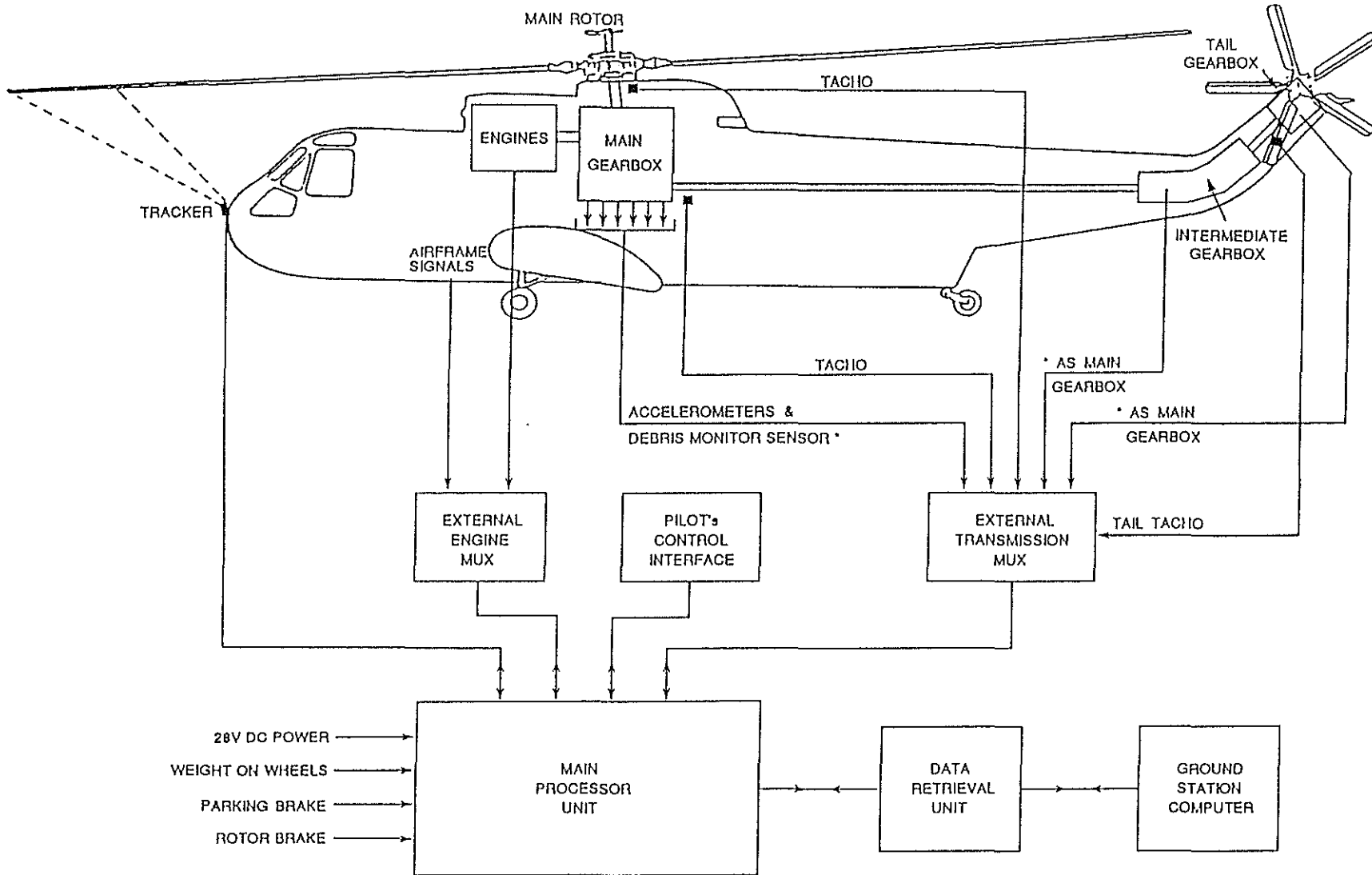
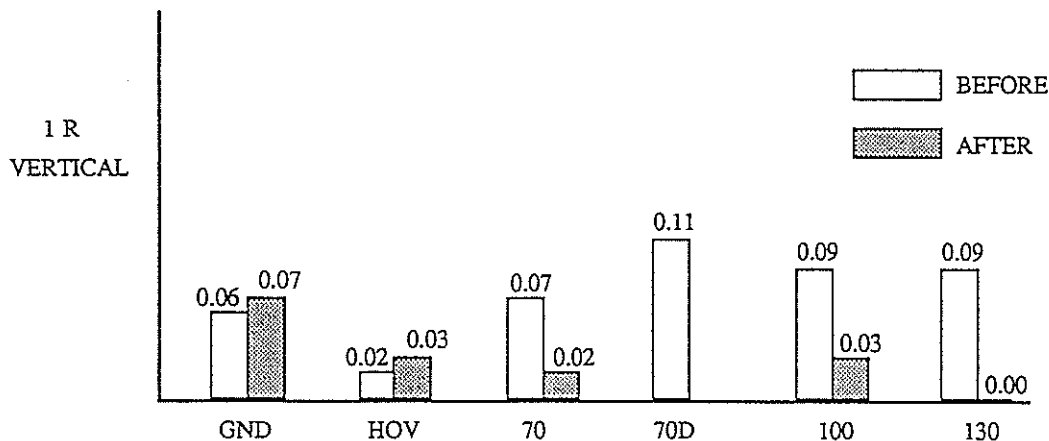
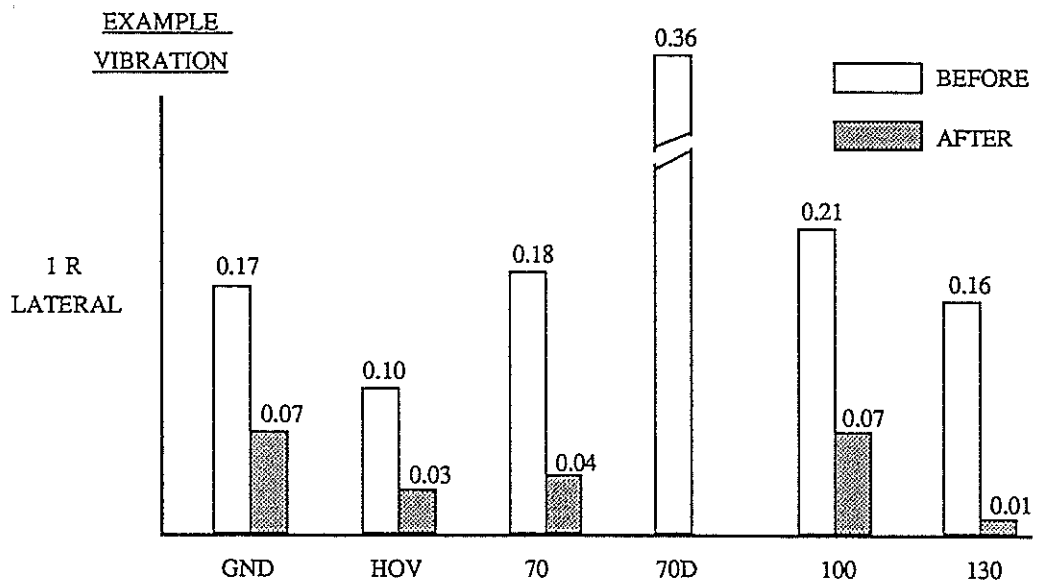

FIGURE 1 : Overall system block diagram

ADVANCED DIAGNOSTICS

- * BASED ON MATHEMATICAL OPTIMIZER PRINCIPLE
- * TRUE ONE SHOT DIAGNOSTICS



TRACK

	<u>BEFORE</u>				<u>AFTER</u>				
	BLK	BLU	YEL	RED	BLK	BLU	YEL	RED	
GND	9	2	0	1	GND	3	5	0	2
HOV	8	2	0	6	HOV	-2	2	0	5
70	9	0	0	-5	70	-4	1	0	-5
70D	7	0	0	-4					
100	8	-1	0	-8	100	-4	1	0	-7
130	9	-3	0	-13	130	0	1	0	-10

TRACK RELATIVE TO YELLOW (MASTER)

FIGURE 2 : Advanced diagnostics

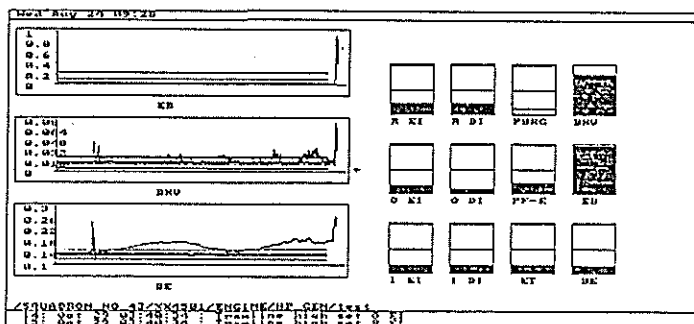
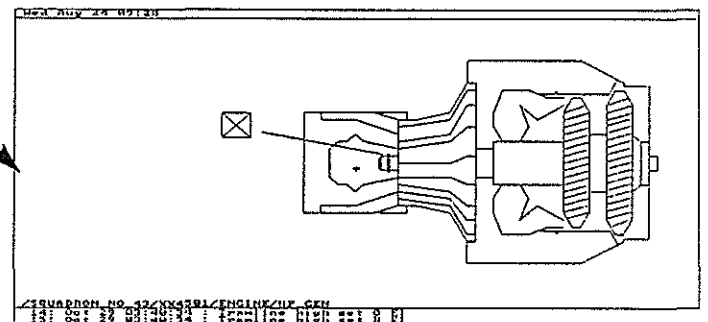
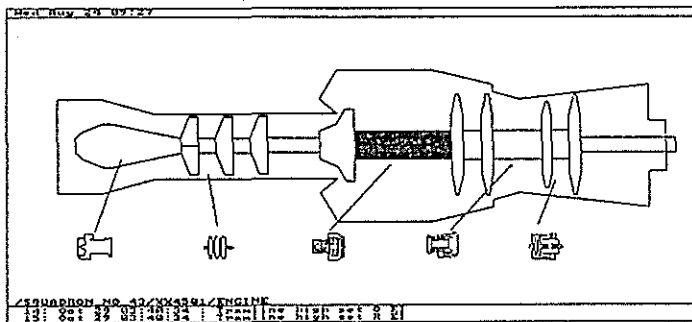
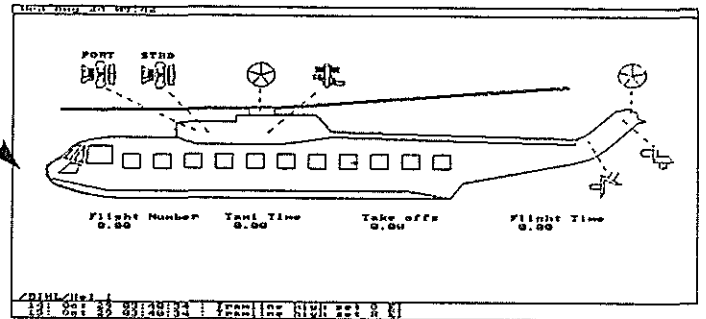
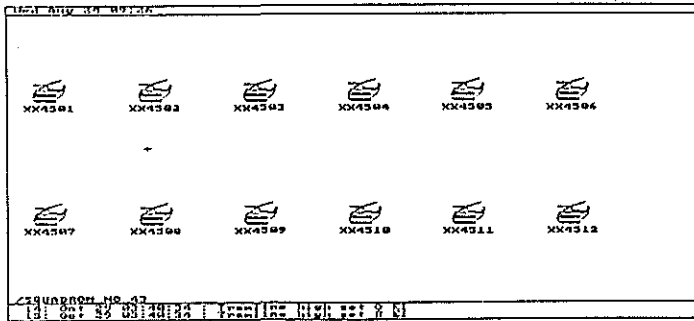

FIGURE 3 : Ground station graphics displays