

NINTH EUROPEAN ROTORCRAFT FORUM

Paper No. 97

FLIGHT TESTING THE ROTOR SYSTEMS
RESEARCH AIRCRAFT (RSRA)

G. WARREN HALL

NASA Ames Research Center
(NAS Moffett Field, California)
USA

and

LT. COL. ROBERT K. MERRILL

US Army Aviation Engineering Flight Activity
(Edwards Air Force Base, California)
USA

September 13-15, 1983

STRESA, ITALY

Associazione Industrie Aerospaziali

Associazione Italiana di Aeronautica ed Astronautica

FLIGHT TESTING THE
ROTOR SYSTEMS RESEARCH AIRCRAFT (RSRA)

by

G. Warren Hall
NASA Ames Research Center
Moffett Field, California
USA

and

Lt. Col. Robert K. Merrill
US Army Aviation Engineering Flight Activity
Edwards Air Force Base, California
USA

In the late 1960's, efforts to advance the state-of-the-art in rotor systems technology indicated a significant gap existed between our ability to accurately predict the characteristics of a complex rotor system and the results obtained through flight verification. Even full scale wind tunnel efforts proved inaccurate because of the complex nature of a rotating, maneuvering rotor system. The key element missing, which prevented significant advances, was our inability to precisely measure the exact rotor state as a function of time and flight condition. Two Rotor Systems Research Aircraft (RSRA) were designed as pure research aircraft and dedicated rotor test vehicles whose function is to fill the gap between theory, wind tunnel testing, and flight verification. This paper describes the two aircraft, the development of the piloting techniques required to safely fly the compound helicopter, the government flight testing accomplished to date and proposed future research programs.

The Rotor Systems Research Aircraft Development Program is not a new program. As shown in Figure 1, the concept of providing a test bed aircraft for research in new candidate rotor systems and rotorcraft technology began in 1970. Developed by Sikorsky Aircraft under a joint Army/NASA contract, two aircraft were delivered to the government in 1979 and are currently being flight tested at NASA's Ames Research Center, Moffett Field, California. While initial testing was conducted by Sikorsky, this paper is limited to describing the aircraft and government flight testing accomplished to date.

- 3 DECEMBER 1970 - NASA/ARMY WORKING GROUP ESTABLISHED
- 1 NOVEMBER 1971 - JOINT NASA/ARMY DEVELOPMENT AGREEMENT
- 1 MARCH 1973 - REQUEST FOR PROPOSAL (BELL/SIKORSKY)
- 6 NOVEMBER 1973 - SIKORSKY AWARDED CONTRACT
- 12 OCTOBER 1976 - FIRST FLIGHT - HELICOPTER
- 10 APRIL 1978 - FIRST FLIGHT - COMPOUND
- 12 FEBRUARY 1979 - HELICOPTER ARRIVES AT AMES RESEARCH CENTER
- 29 SEPTEMBER 1979 - COMPOUND ARRIVES AT AMES RESEARCH CENTER
- 23 FEBRUARY 1980 - FIRST HELICOPTER FLIGHT AT AMES RESEARCH CENTER
- 25 NOVEMBER 1981 - FIRST COMPOUND FLIGHT AT AMES RESEARCH CENTER

Fig. 1. RSRA Chronology

In the late 60's, efforts to advance the state-of-the-art in rotor systems technology, while meaningful in their own right, indicated that a significant gap existed between our ability to accurately predict the characteristics of a complex rotor system and the results obtained through flight verification. Even full scale wind tunnel efforts proved inaccurate because of the complex nature of a rotating, maneuvering rotor system.

The key element missing, which prevented significant advances, was our inability to precisely measure the exact rotor state as a function of

time and flight condition. The "trial and error" method proved costly, both from the fiscal considerations and the extreme risk to flight crews. Each candidate rotor system required the development or modification of an airframe to match the system under study. Every rotor system research effort, in fact, became a total aircraft development program. There was a general reluctance to depart very far from proven, successful concepts to investigate innovative, yet unproven rotor systems. Designed as a pure research aircraft, the RSRA is a dedicated rotor test vehicle whose function is to fill the gap between theory, wind tunnel testing, and flight verification. The term "flying wind tunnel" has been coined to describe perhaps the most sophisticated and complex vehicle to join the research aircraft inventory.

A research vehicle, in order to be useful, must have certain basic capabilities. A flight test envelope must exist which will encompass the expected envelopes of future rotor systems under all flight conditions. Versatility must be provided within the flight control system to exploit this envelope and to allow accurate, repeatable test results. Finally, a measurement and data acquisition system must be provided to accurately record desired flight parameters such that useful data analysis can be performed in a comprehensive manner.

To provide the required performance capability, the test configurations of the RSRA consist of a compound helicopter, (Figure 2) and a helicopter mode and, if necessary, removing the rotor from the compound allows the RSRA to be flown as a fixed wing airplane. The fixed wing configuration primarily provides a flyback capability should it become necessary to sever an unstable rotor system in flight.

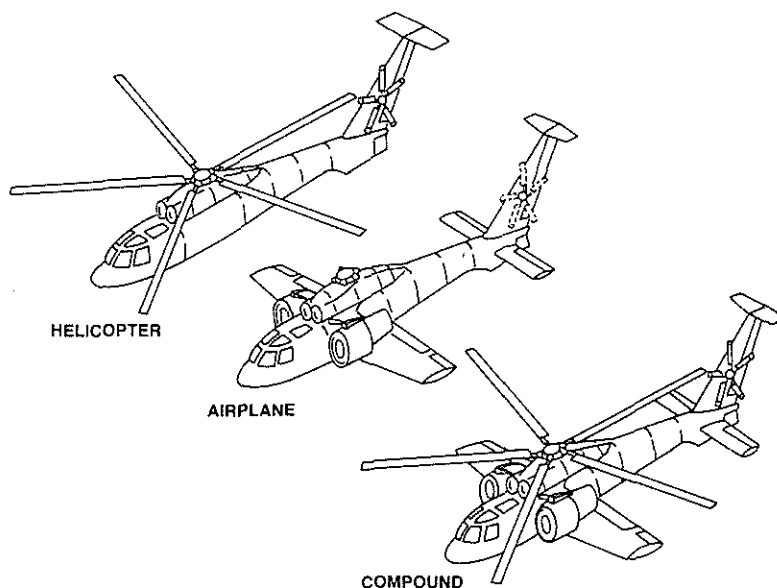

Fig. 2. RSRA Flight Configurations

The primary research configuration is the compound helicopter. Common to both configurations, however, is the basic helicopter fuselage which incorporates an S-61 rotor, transmission, drive train and tail rotor, driven by two GE T-58 engines. These proven systems and the S-61 rotor provide an adequate performance envelope and capability to allow a thorough systems integration flight evaluation and development of an adequate reference data base for comparison with future rotor designs.

The compound configuration has a 45-foot wing which can change its angle of incidence between 15 degrees leading edge up and 9 degrees leading edge down. This capability allows one to vary the required rotor thrust from zero, to that which would be representative of a much heavier aircraft. The wing contains conventional ailerons and high frequency flaps, both of which can be operated by an on-board digital computer.

The tail section contains a conventional helicopter tail rotor, a lower horizontal all flying stabilator, an upper fixed horizontal tail plane, a conventional rudder and two large aft mounted drag brakes. All of these controls can be operated from the cockpit controls or by the electronic flight control system.

Auxiliary power plants are mounted on either side of the fuselage. These GE TF-34 high by-pass turbojet engines are used to offset the drag effects of a candidate rotor system. The compound configuration weighs approximately 27,000 pounds which means, with its present rotor system, it is unable to hover and has a minimum speed of 40 knots.

Since the winged configuration precludes hover, the second configuration of the aircraft is the pure helicopter. This configuration fills the performance gap and allows complete investigation of the candidate rotor system in the hover and low speed regime. In building up to the full compound configuration, the basic airframe was first flown as a helicopter to check out those systems common to both prior to adding the compound unique systems. We have been able to continuously fly the helicopter to maintain our flight proficiency, and to use it as a compound simulator in developing and practicing our compound techniques. Seventy knot roll-on landings in a helicopter are exciting, but proved to be excellent training in the techniques and crew coordination required for flying the compound.

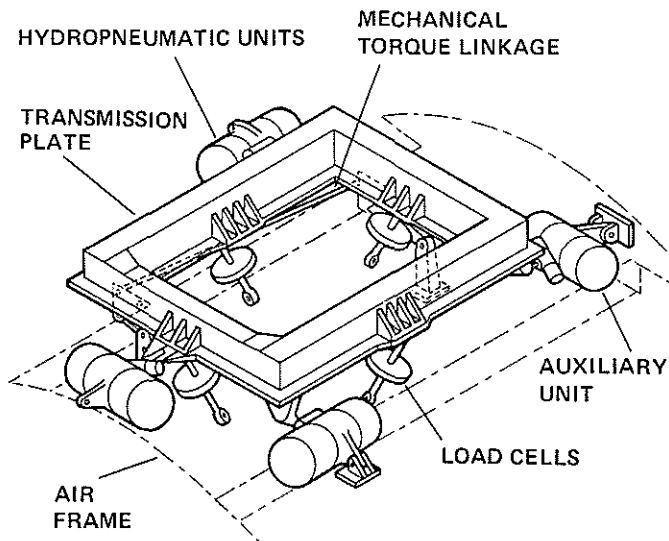

Fig. 3. Rotor Force and Moment System:
Active Isolation and Balance System
Configuration

The helicopter also incorporates a unique Active Isolation and Balance System (Figure 3). This system was designed to provide an acceptable airframe vibration level and rotor load measurement capability over the wide range of rotor excitation frequencies that might be experienced with different experimental rotor systems.

The RSRA flight control system was designed to provide versatility for the flight research task and is truly unique. With the increased number of control surfaces available in the compound, a means of "control sharing" had to be incorporated. This was accomplished by providing a control phasing unit, or CPU. The CPU allows the pilot to select the proportion of control inputs to be made by the fixed or rotary wing control surfaces. The CPU is available for all three primary control axes. This means the pilot can select full rotary wing or full fixed wing control or any combination of the two. The capability to vary the control phasing was demonstrated during the government flight tests.

The flight control system provided specifically for the research task is an electronic "fly-by-wire" system (Figure 4). The evaluation pilot flies the aircraft through electrical signals which are ultimately summed into the primary mechanical control system. This summing can be either direct, through a force feel system, or through a digital computer. Safety dictated one crew member must have direct positive override control

capability of the aircraft at all times, thus, an essentially standard hydromechanical control system is also installed.

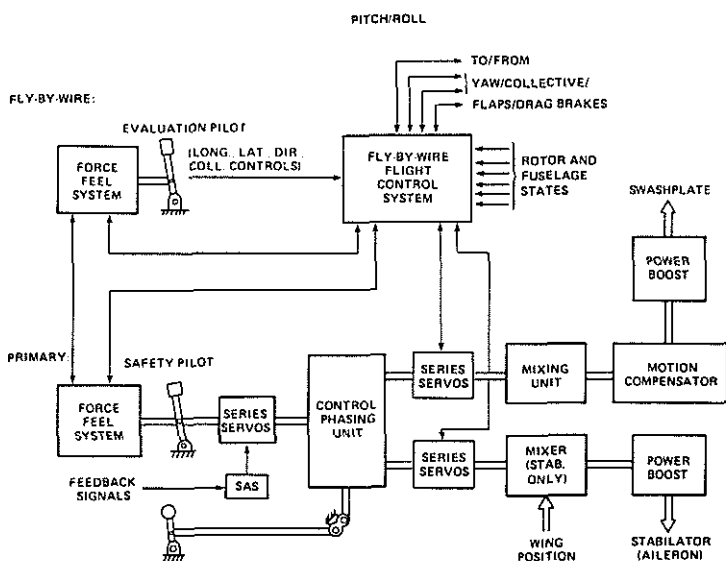

Fig. 4. RSRA Flight Control System Configuration

The heart of the electronic flight control system is the Teledyne TDY-43 general purpose, flight qualified, digital computer that can be programmed in numerous ways to provide changes in stability and control or force feel system gains. By varying the computer program, the RSRA can be used as a 5 degree of freedom inflight simulator in studying the handling qualities associated with a research rotor. The computer also can be programmed to make various control inputs in a predetermined direction and magnitude insuring repeatability of research control inputs.

A third flight crewman, the research engineer, has direct access to the computer so that the software may be monitored and gains changed in flight.

The ultimate goal is to allow the electronic flight control system to be programmed to move the various control surfaces in such a way to collect in-flight rotor data in a manner similar to a wind tunnel program.

Just as the heart of any wind tunnel is its balance and data gathering system, the uniqueness of the RSRA is its force and moment measurement system allowing direct accurate inflight measurements of rotor forces and moments.

The forces and moments generated by the main and tail rotors, auxiliary engines, and the wing are measured by a series of load cells and/or the Active Isolation and Balance system which are an integral part of the aircraft structure (Figure 5).

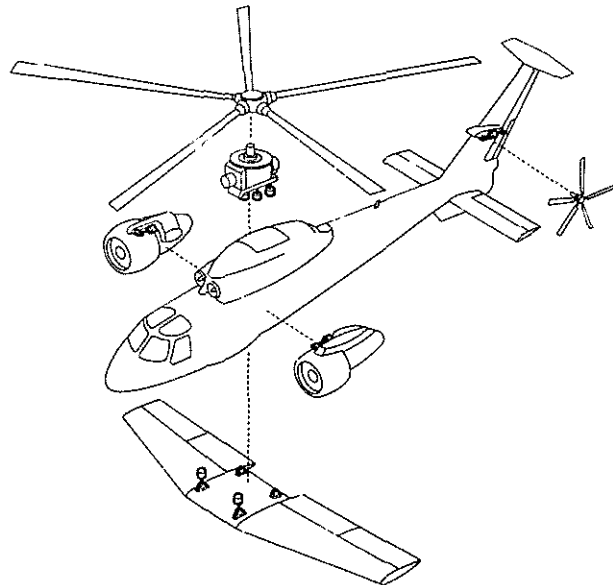

Fig. 5. RSRA Force and Moment Measurement Systems

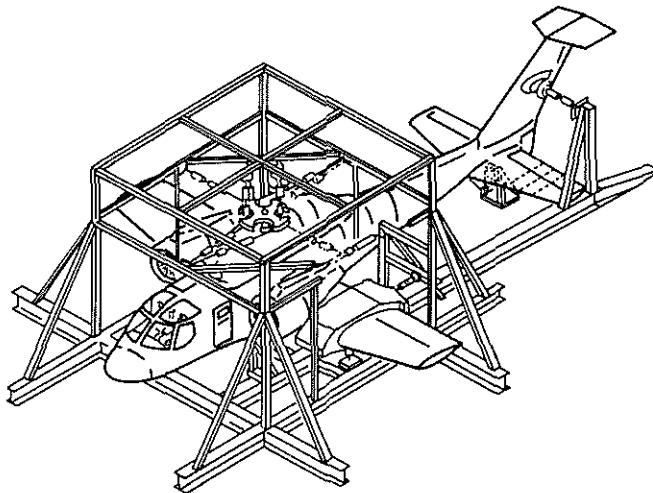

Fig. 6. Flight Loads Measurement Systems Calibration Fixture

The measurement system was calibrated in Ames Research Center's Static Calibration Facility (Figure 6). The inflight data is recorded by an extensive onboard instrumentation system. A real time telemetry system allows the test engineers on the ground to monitor critical flight parameters and aircraft limits.

During the initial design considerations, it was deemed necessary to provide the flight crew with an escape system. This was especially true in the compound configuration where the proximity of the auxiliary engines, wing, and tail to the normal escape windows preclude a manual bail-out at even moderate airspeeds.

The Emergency Escape System (EES) is perhaps the most innovative system developed for the RSRA.

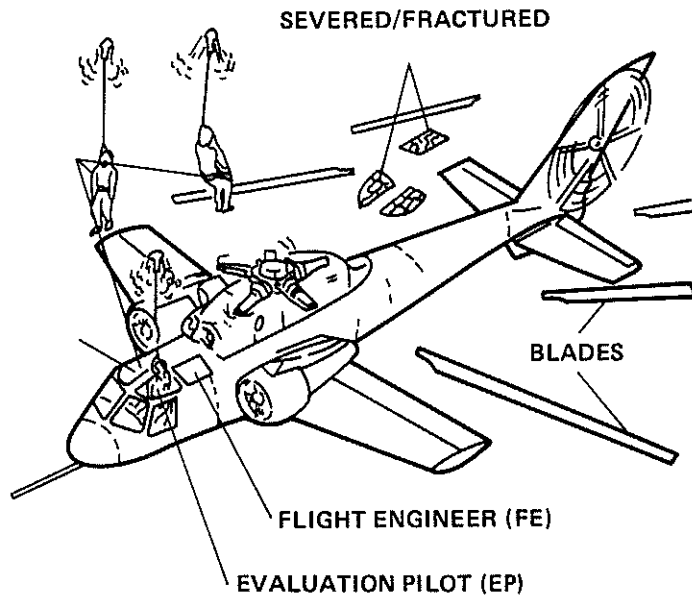

Fig. 7. RSRA Crew Escape System

The resulting escape system (Figure 7) is truly an engineering masterpiece. It is a modification of the Stanley "Yankee" extraction system, used successfully in the T-28 and A-1 aircraft in Southeast Asia.

The "full escape" system consists of a dual, completely redundant network of pyrotechnic transfer lines to various components which: (1) sever the main rotor blades near the hub, (2) fracture the overhead canopies, (3) launch the tractor type main escape rockets to extract the 3 crew members and, (4) provide for a fully automatic parachute deployment and seat separation.

The Egress system was fully qualified through extensive component and full-scale rocket-sled testing at Holloman AFB, New Mexico. In five sled tests at speeds ranging from 0 to 210 knots, thirteen extractions of instrumented dummies resulted in a 100% success rate.

The egress system is initiated by pulling upward on one of the handles mounted on the front edge of the pilot seats; the three crewmen are automatically retracted into their respective seat backs to ensure proper egress positioning; the pilot's cyclic sticks are hinge released at the base with a pyrotechnic pin; the rotor blades are sequentially explosively severed at predetermined azimuthal positions relative to the airplane to avoid striking the tail or throwing a blade into the flight path; the canopies above the crewmen are explosively severed and fractured; the safety pilot and flight engineer's extraction rockets are launched; 1.4 seconds later the evaluation pilot's extraction rocket is fired (to prevent interference); when the extraction lines become taut, the crewmen are extracted in a standup position. The recovery parachutes are deployed from a container on the bottom of the seat pan by a static line attached to the aircraft. The seat assembly is released from the crewman by pyrotechnic-actuated mechanisms, allowing a normal descent and touchdown.

The escape system envelope is a function of forward speed, roll angle and rate of sink. In general, the helicopter configuration requires a higher minimum escape altitude and is more sensitive to roll and sink rate than the compound. The aircraft forward velocity limit for safe egress is limited by the close proximity of the flight engineer to the rotor engine inlets and by the clearance of the parachute deployment bag to the aircraft for the two pilots.

While studies and limited experimentation with helicopter escape systems had been conducted, until the development of the RSRA, no complete system had been designed, fabricated, tested and declared qualified and operational.

In the compound configuration we also have the option of severing the rotor blades only, allowing a return to base as a fixed wing airplane. The "Blades Only" mode is initiated by a handle located on the overhead console between the two pilots. The blade severance is the same as in the full egress system, however an additional system is provided to ensure the rotary wing engines continue to run, following rotor blade severance,

since they are required to drive the main and accessory gear boxes to provide electrical and hydraulic power. The tail rotor continues to run.

With the rotor system force measurement system calibrated, and with the aircraft in the helicopter configuration, the RSRA conducted its first research program. Highly accurate vertical drag information was obtained in hover and at low speed allowing determination of rotor down-wash and fuselage interference effects. Measurements never before possible in actual flight were achieved. This also allowed us to increase our level of proficiency in preparation for our first flight in the full compound.

With the completion and analysis of the data from the Vertical Drag Program, the aircraft was reconfigured as a full compound and a program designed to fully document baseline data, resolve structural problems found during the contractor flight test program and expand the envelope to the full research capabilities of the aircraft began. We had many factors on our side in preparing for flying the compound configuration:

1. We had been extensively flying a program on the RSRA helicopter and at every opportunity were practicing compound techniques;
2. We had developed a high fidelity, compound helicopter simulation on the Flight Simulator for Advanced Aircraft at Ames; and
3. The corporate memory from several years previous was still present in flight test engineers, pilots, and other personnel associated with the program.

Takeoff Technique: Previous experience making rolling takeoffs in the helicopter and with the concurrent development of a high fidelity simulation indicated a takeoff technique that was a compromise between that used for a tail dragger fixed wing aircraft and a rolling takeoff for a heavy weight helicopter would be required. Several factors were to play an important role in the selection of our final technique:

- High power settings of 65% fan speed or greater on the TF-34 engines at zero velocity caused structural damage to the lower horizontal tail because of exhaust and bypass air impingement.
- There were several unknown factors about directional control in the 40 to 70 knot range.

- The inability to set a precise power setting on the TF-34 twist throttles because of hysteresis and high forces in the throttle system,
- And finally, the presence of the quite large collective to pitch coupling observed both in the simulator and during our helicopter flights.

As a result of a lot of thought, helicopter flying, and a series of simulation sessions, the following technique was developed:

The sequence for takeoff was:

- Establish the cyclic in the near center position using the cockpit control position indicators keeping the collective full down until the takeoff roll begins.
- Slowly advance the TF-34 engines to takeoff power as the aircraft rolls forward.
- As takeoff power is stabilized, collective is increased slowly to arrive at 40 percent collective position and 70 knots simultaneously.

With the 10 degree incidence on the wing, the aircraft simply flies off the runway in the 3 point attitude with only minimal control input required to maintain that attitude.

Acceleration to 90 knots occurs quite rapidly, and without changing power; a slight aft cyclic movement results in a 90 knot climb.

Up and away flight is very comfortable, much more so than with the helicopter. The compound is more stable and exhibits less vibration. All flight cards were extremely busy, with the goal of accomplishing as much as possible in the short flight time available to this four engine aircraft.

Landing Technique: Again, a wide range of options were available. If the compound was to be flown as a pure helicopter, a run-on landing was the way to go. The jets would be reduced to idle on the base leg and collective and cyclic would be the primary controls for glidepath and airspeed control.

If it was going to be flown as a pure fixed wing airplane, a fixed collective with cyclic controlling airspeed and TF-34 engine modulation providing glidepath control would be best. At altitude we were able to reduce to approach speeds, and had the opportunity to try both techniques. As the simulation had indicated, the fixed wing technique proved to be best.

The approach speeds selected were 110 knots downwind, 100 knots on base leg, and 90 knots on final. This provided an adequate margin above stall on the wing, which we were able to monitor with an angle of attitude indicator, and, with the use of flaps to increase drag, put us in a "straight line" region of TF-34 thrust modulation to control glidepath.

After several landings, it was determined that by maintaining a 20 percent collective setting and the airspeeds mentioned above, crossing the fence at 90 knots with a flare at the bottom put the aircraft in a slight tail low attitude at 70 knots. After we began moving the wing in flight, we found that a 7-1/2° wing incidence put us in precisely a 3 point attitude with jets at idle and 70 knot touchdown target. There is no tendency to float or enter any kind of PIO in ground effect. If, in rare occasions, one misjudges the location of the wheels and ends up slightly high prior to touchdown, a slight downward pressure on the collective provides the flexibility to recover gracefully.

Wing Movement Development: During the contractor flight test program the variable incidence wing had not been moved in flight. Thus, it was important to determine very early what effect varying the wing incidence would have on the structural loads and aircraft handling qualities.

The initial movement of the wing in flight proved to be rather benign. Essentially, the fuselage rotates about the wing and the angle of attack remains constant. The wing to elevator interconnect practically negates the requirement for a cyclic trim change.

The only noticeable effect on the handling qualities with a change in wing incidence is a new flight attitude in cruise and quite different power requirements for the auxiliary engines during turning flight. The higher wing incidence angles require considerably more power in a turn to maintain a constant speed.

The greatest influence of wing incidence is on where the maximum stresses occur during high speed flight. Much of the flight test effort has been devoted to mapping the structural loads as a function of wing incidence and collective setting.

The limiting structural loads at high speed occur either in the main rotor blades or in the upper horizontal stabilizer. At high wing incidence angle, the horizontal stabilizer reaches its endurance level around 180 knots. At low wing incidence angle, the main rotor blades reach their endurance levels at about the same speed. A lowering of the collective tends to reduce the rotor loads.

To date, the structural loads on the aircraft have been mapped at wing angles of 0, 5, 7-1/2, and 10° from 50 to 180 knots at several collective settings. We have explored flight techniques which enable us to minimize cumulative damage on components in transitioning from one flight region to another. All of these techniques and the knowledge gained to this point will be used in designing programs for future rotor systems to be studied with the aircraft.

The future of the RSRA is bright. Initial experimental rotor system proposals have been submitted and evaluated, and award of the contract and fabrication should begin this year (1983).

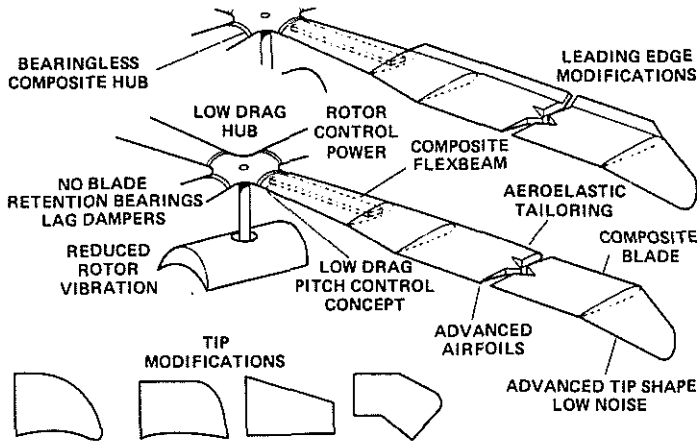

Fig. 8. Proposed Four-Bladed Rotor

The initial system will be a 4-bladed rotor (Figure 8) with the capability of varying blade geometry and inertia, to study, and more importantly, to measure the effects of pure rotor design and design changes on the airframe and rotor combination, holding other variables constant in a manner which has not been possible to date.

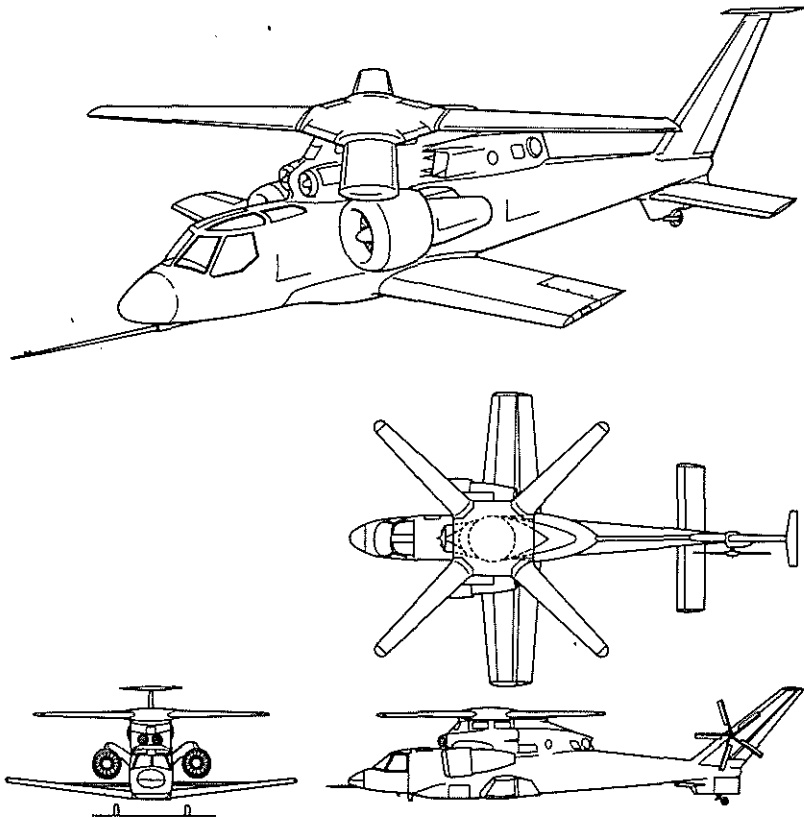

Fig. 9. Artist Concept of Proposed X-Wing Configuration

Another major use of the aircraft is the development and inflight demonstration of the "X-wing" concept (Figure 9). One proposal is to reconfigure the pure helicopter as a compound aircraft and install this innovative and highly experimental system for flight test.

The RSRA gives the flight test community a versatile tool. It is truly a "flying wind tunnel" and will play an important role in advancing the state of the art in helicopter rotor systems design. The government flight tests have explored all capabilities of the RSRA and we feel it ready to commence the research for which it was designed.