

# **The Health and Usage Monitoring System of the Westland 30 Series 300 Helicopter**

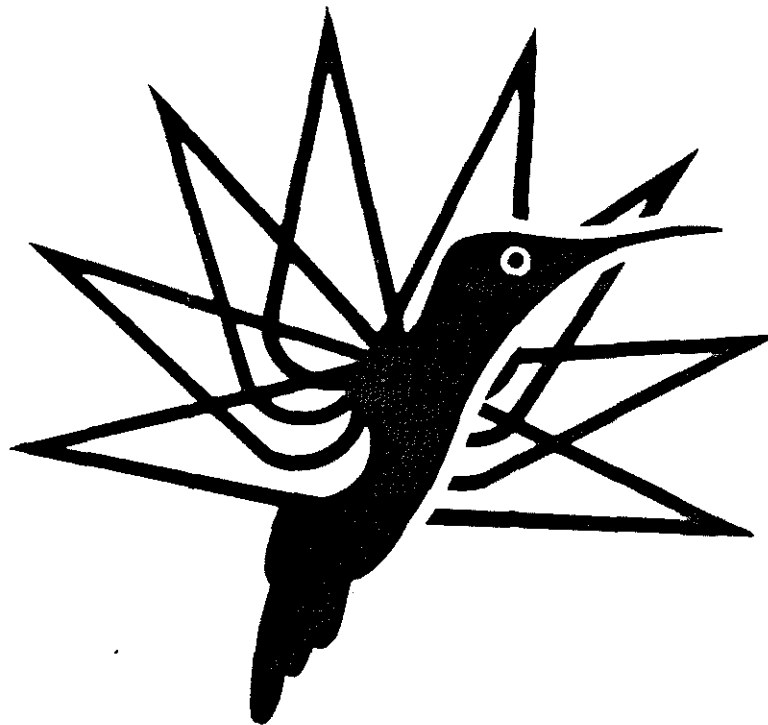

by

D G Astridge and J D Roe

**Westland Helicopters and Hovercraft Ltd**

TENTH EUROPEAN ROTORCRAFT FORUM  
AUGUST 28 — 31, 1984 — THE HAGUE, THE NETHERLANDS

THE HEALTH AND USAGE MONITORING SYSTEM  
OF THE WESTLAND 30 SERIES 300 HELICOPTER

D G Astridge

and

J D Roe

Westland Helicopters and Hovercraft Limited

ABSTRACT

The design philosophy behind the health and usage monitoring developments on the Westland 30 series of helicopters is discussed including their relevance to the recently published review of helicopter airworthiness (HARP report). The necessity for a comprehensive on-board data processing system such as that described in this paper becomes patently obvious. The functions included in the system relate to engines, the transmission, and rotor systems. Experience has been gained with the implementation of many of these functions separately on development and production aircraft. Details are given of the processor, its interfaces, data links, sensors, and data retrieval unit, together with an overview of the development programme.

1. INTRODUCTION

Effective health and usage monitoring can make a major impact on aircraft availability, airworthiness, cost of ownership, and on workload - for both pilot and for groundcrew. The potential value of HUM to the improvement of airworthiness of helicopters is underlined in the recently published review by the Airworthiness Requirements Board (Ref. 1). The report calls for a marked improvement in helicopter airworthiness and emphasises the point that, unlike fixed wing aircraft, safety and reliability are highly correlated in helicopters. In reviewing much of the available data in the Western World on failures of equipment and the causes of accidents, the review panel noted that:-

- i) Overall engine reliability is not good.
- ii) The principal source of critical failure lies in the rotor-transmission area.
- iii) Contributory factors are inadequacies in detail design, in substantiation testing, and in the prediction of duty cycles in service.

Ideally, safety - critical components should be designed 'fail - safe' or tolerant to damage, internally or externally generated. Those components that are not amenable to this approach are either duplicated (eg engines, electrical generation and hydraulic systems), or, where this is not feasible are subject to 'safe - life' substantiation by rig tests, tie-down aircraft tests, and flight experience (eg gears, rotor hubs, and blades). Health and usage monitoring systems are relevant to all three categories:-

- (a) fail-safe: Adequate damage detection systems to cope with unforeseen excursions in operating/environmental conditions or material/manufacturing tolerances.
- (b) safe-life: Usage monitoring systems for measuring load exposure provide a more reasonable basis for retirement than flying hours. Health monitoring as above, plus the need to cover deficiencies in substantiation tests or prediction of service severity. Performance monitoring on engines to cope with environmental and material/manufacturing excursions.  
  
'Vital Parts' procedures in design and manufacture as implemented at Westland add significantly to the achievement of maximum airworthiness.
- (c) redundancy: Status monitoring to indicate and identify loss of channel. Health monitoring to reduce possibility of in-flight loss of channel.

Economic and functional issues should also be considered. Health and usage monitoring systems offer significant cost reduction benefits both in aiding substantiation of safe lives and in prolonging time in service where conditions allow. Contributions to reduction in workload, be it that of pilot or ground-crew, benefit both flight safety and cost of ownership. It is therefore not considered necessary to wait for any regulatory requirement before introducing effective HUM systems.

The health and usage monitoring system (HUM) of the Westland 30 series 300 helicopter represents a major advance in on-board monitoring facilities addressing the requirements outlined above. The system was briefly described in a paper presented at the 1983 Rotorcraft Forum (ref 2), and this paper gives a more detailed description of the philosophy, specification, implementation, and certification aspects. The integrated system gathers data from engines, rotor systems, and the complete transmission. A dedicated computer analyses the data and stores processed information for interrogation and retrieval by maintenance personnel. The combined use of health monitoring and usage monitoring permits improved airworthiness of helicopters on the one hand, and on the other, allows the useful life of expensive components to be maximised within flight safety constraints.

## 2. HEALTH AND USAGE MONITORING PHILOSOPHY

- 2.1 Usage, or load exposure monitoring (eg torque - time for transmissions, number of speed cycles for engines) requires the analysis of data retrieved on a total, continuous basis. To attempt the on-board storage of data and unloading to ground facilities for analysis is clearly impractical when considering the number of data channels concerned (2 or 3 input torques, tail drive shaft torque, 4-9 engine shaft speeds, 2 or 3 engine turbine entry temperatures, plus several strain gauge signals from rotor heads) and the large volume of data per channel. Clearly the analysis must be performed on-line, and the simple cumulative 'usage units' (eg total time within a narrow band of torque) stored for transfer to ground data banks, either by telemetry or by portable data retrieval units. The experience gained with ground based analysis of raw data transmitted by both of these methods has demonstrated the wisdom of on-board data reduction. Slight extension of on-board storage capacity enables cumulative damage totals to be accumulated for each 'safe-life' component, permitting instant after-flight status indication of each module (eg main rotor gearbox) without the need for further processing of data on the ground.
- 2.2 Performance monitoring on engines for Power-Performance Index calculation has of necessity to be carried out in-flight, at relatively high power conditions. At present PPI checks often necessitate special flights, and the data recording and analysis is carried out by aircrew. The advantages of performing this task with an on-board processor are clear: airworthiness - accuracy and frequency; aircraft availability - PPI check performed at end of days operation; workload - relieves pilot of task; cost savings - obviates need for special flights.
- 2.3 Damage propagation rate in some 'safe-life' components can be rapid relative to flight cycle times. The HARP report (1) indicates that failures of this type do occur to an unacceptable degree for the reasons listed earlier. Fracture initiation usually occurs only at very high load conditions, and the detectability of fracture propagation by on-line methods may only be possible at high load conditions. On-board analysis and pilot warning is therefore necessary to meet this requirement.
- 2.4 Ground taxi-ing of helicopters operating at civil airports can impose fatigue damage to undercarriage, rotor systems, and aircraft structure unless such operation is restricted to non-damaging conditions. Main rotor moment monitoring provides a means of indicating safe limits of operation to the pilot, and means of assessing cumulative damage should exceedances occur. Such a facility requires on-board sensors, data processing and display.

2.5 On-board data processing facilities installed to perform the above tasks require insignificant extension to perform additional health monitoring tasks that might otherwise be carried out on the ground (eg manual retrieval of quantitative wear debris displays, and track and balance checking of rotor systems).

### 3. FUNCTIONS PERFORMED BY THE W30-300 HUM SYSTEM

The HUM is being designed to perform the following functions.

#### 3.1 Engines

- i) Compute Power Performance Index for each engine.
- ii) Monitor Low Cycle Fatigue of all engine rotors.
- iii) Monitor Thermal Creep of hot-end components.
- iv) Monitor Limit Exceedance of engine rotor speeds and turbine entry temperature.

#### 3.2 Transmission

- i) Monitor Torque usage.
- ii) Monitor Diagnostic Vibration (enhanced signal averaging)
- iii) Store outputs from Quantitative Wear Debris Monitors (QDM).

#### 3.3 Rotor Head

- i) Monitor head usage (torque, strain, flying hours, major cycles).
- ii) Monitor and display rotor head moment.

The components of the W30-300 HUM system are shown in figure 1.

### 4. EXPERIENCE WITH HUM FUNCTIONS

The various components of the system are all derivations of similar systems with which Westland have already gained experience.

#### 4.1 Engines

- i) PPI - The algorithm employed is identical to the one utilised by the interseat console mounted Performance Monitor of the Westland 30 Series 200 produced by Dowty Electronics to a Westland specification. This system, more completely described in ref. 2, is currently undergoing Flight trials.
- ii) Engine usage - These functions are identical to those of the Series 200 system, which are developments of those of the General Electric Engine History Recorder as fitted to the GE T700-700 on the US Army Black Hawk.

## 4.2 Transmission

- i) Torque Usage - A simplified torque usage algorithm is used on the Westland 30 Series 100-60 and Series 200 system. To allow complete usage monitoring a tail driveshaft torquemeter is used in addition to engine torquemeters. Similar torquemeters manufactured by EEL have been used during development flying of Wessex, Sea King, Lynx, Puma, and Westland 30. (fig. 2)

Development flying experience has been gained with micro-processor analysis of transmission torque signals from the above tail rotor drive shaft unit and from existing engine torquemeters. The processor dedicated to this task was the "ACE 85" digital engine control unit produced by Hawker Siddeley Dynamics Engineering, with an internal board modification for this task (fig. 3). Cumulative damage totals for all life - limited gears in the Sea King transmission were retrieved after each flight by means of a hand-held data transfer unit which displays each damage total in sequence.

- ii) QDM and Vibration

Considerable experience has now been gained with the wear debris monitoring system and diagnostic vibration monitoring sensors and analysis - these have been installed on all Westland 30 series 100 aircraft since their introduction into service in 1982(2). The TEDECO Quantitative Debris Monitor sensor is fitted to the main rotor gearbox sump in a position of high debris catch efficiency, established from development rig tests. On the series 300 aircraft QDM sensors will be fitted to intermediate and tail rotor gearboxes as well. The number of accelerometers mounted on gearbox casings will be increased slightly in this aircraft to cater for the additional engine reduction gearboxes (in common with the series 200 aircraft). At present the vibration analysis is performed on a ground-based mini-computer using data recorded from a short ground run. The same analysis programs are being incorporated in the series 300 HUM computer. Algorithms have been verified on extensive component rig tests to deliberate failure.

## 4.3 Rotorhead

The FM-telemetry head monitoring system is a development of the tail torquemeter system and utilises EEL's many years of strain gauge experience on helicopters including Scout/Wasp.

#### 4.4 On-Board Processing

Extensive experience has been gained with on-board digital recording and processing systems and long-range telemetry on several development aircraft. This includes the monitoring of a wide range of parameters relating to operational data recording (HODRS - ref. 3). A naval helicopter has been flying for some time with the Plessey HODRS system recording operational data.

### 5. DESCRIPTION OF FUNCTIONS

#### 5.1 Engine Monitoring

The engine monitoring includes

- Power Performance Index Computation
- Low Cycle Fatigue Monitoring
- Limit exceedance Monitoring
- Thermal creep monitoring

The computer will calculate on operator demand (and once stable conditions have been established) the Power Performance Index (PPI) of a selected engine : the PPI is computed for the Power Turbine Temperature (T4.5) and engine torque, correcting automatically for ambient temperature, pressure and altitude. The result is available for display to the pilot and stored for maintenance trending purposes.

The Service Bulletin for the General Electric CT7-2B lists 21 components/assemblies with cyclic lives. These will be lifed on combinations of the two numbers calculated and stored in the computer. The current service bulletin makes pessimistic assumptions of life for the manual calculation procedure. This pessimism can be removed with the introduction of the computed algorithms of Westland 30 Series 200 and 300.

General Electric currently identify maintenance action based on temperature (T4.5) exceedance. This function will be automated by the computer. This function coupled with the Time-Temperature Index for thermal creep monitoring is expected to be used in the future for a different rating structure for the engine (ref 4).

#### 5.2 Transmission Monitoring

The transmission monitoring includes:

- Torque usage monitoring
- Bearing degradation (TEDECO QDM system)
- Tooth Fracture modes (vibration monitoring)

Using the engine input torque and tail torque values it is possible to combine these values in the proportions relevant to any gear of interest and store the torque-time spectrum and the actual fatigue damage accrued during operation above maximum continuous ratings. In this way the most relevant of the many vital gears in the transmission can be monitored. Torque monitoring of the tail rotor gearbox allows the removal of the design scatter factor allowance for load definition, giving a reduction in weight.

Due to the great importance of bearings in the helicopter transmission (ref 1) the Quantitative Debris Monitoring System (QDM) has been extended to all gearboxes on the Series 300. The computer collects the particle counts of each QDM sensor. This enables all Health and Usage maintenance inspection to be accomplished from a single point. Vibration monitoring will normally be carried out once per flight during a period of stable flight (possibly in conjunction with the PPI check). The Westland developed technique enables a gear degradation index to be assigned to each gear.

The algorithms employed allow for variation in gearbox build quality and gearbox-airframe interaction.

### 5.3 Rotor Head Monitoring

The Rotor Head Monitoring includes:

- Usage Monitoring
- Display of rotor head moment during taxi-ing manoeuvres.

The usage monitor extends from the simplest monitoring of rotor starts, torque cycles and flying hours to the most direct by monitoring the strain in flap, lag and control elements of the head, and calculating the usage of all the head components.

The flapping strain is also used to compute head moment. Using the electronic flight instrument system (EFIS) display of the Series 300 a presentation of head moment will be available during taxi-ing to enable the pilot to control its value.

## 6. System Implementation

- 6.1 As a result of competitive tender to a Westland specification, Smiths Industries were selected for the Series 300 computer system.

The computer system comprises three items (fig 4)

- 1) Health and Usage Monitoring Computer
- 2) Display Unit
- 3) Data Transfer Unit (ground use only)



The Westland specified interface between the Computer and the Display Unit is of ARINC 429 type enabling further system integration at a later date if required. The computer also has MIL-STD-1553B interface capability for future military applications.

The interface between the Data Retrieval Unit and the Computer is the standard computer interface type RS 422 or RS 232.

This allows other peripheral equipment to be simply interfaced to the Data Retrieval Unit eg: printers, mainframe computers or telephone modem.

## 6.2 The Computer Unit (fig .5)

In addition to power supply and spares the computer has 8 cards in a  $\frac{1}{2}$  ATR size case. This case bolts down to ease installation.

The computer can be divided into three areas:-

### i) Life Usage Facility and Executive

This undertakes all tasks except vibration and rotor head monitoring and comprises:-

- a) Microprocessor Module - with 4MHz Motorola 68000 16 bit microprocessor, EPROM, RAM and EEPROM.
- b) Input Interfaces - Analogue interfaces:- Air Data, Engine and Transmission Inputs  
Digital Interfaces - QDM
- c) Control Interfaces - ARINC 429 For the Display Unit and EFIS.  
RS422 for the Data Retrieval Unit.

### ii) Vibration Facility

This undertakes the transmission monitoring task and comprises:-

- a) Microprocessor - identical to the Life Usage Processor.
- b) Vibration Memory Module - Stores the signal averages in non-volatile memory. This facility is included to allow additional diagnostic capability with ground based equipment.

The module also holds the enhanced signal averages which are used during the vibration diagnosis.

- c) Vibration Interfaces. This takes in charge amplified acceleration signals and the speed reference signal used for the signal averages.

iii) Rotor Usage Facility

This undertakes the rotor monitoring task and comprises:-

- a) Microprocessor - identical to the Life Usage Processor
- b) Rotor Interface - Taking the conditioned strain gauge inputs from the FM-telemetry Head Monitor and the azimuth signal to reference the waveforms.

Separate microprocessors are required for the vibration analysis and rotor usage due to the large number of samples required and real time processing requirement. In all processing and interface areas additional expansion capability is already available before considering that which will become available due to technology advance.

6.3 The Cockpit Display Unit (Fig 6)

The processor in the Display Unit is a Motorola 6809. The functions of the display buttons are as follows (3 spare buttons are for future growth):-

- VIB - Vibration : initiates the transmission vibration sample during a period of steady flight. Indication will be given if sampling is taking place, when completed, and if completed successfully.
- PPI 1 - Computes the PPI of Engine 1. Indication will be given when parameters are sampled and if the engine is stable. The resulting PPI will be displayed and also stored.
- PPI 2 - As PPI 1 but for Engine 2
- Input - Enables the required input to be selected and displayed.
- Log - Enables any of the usage values to be selected and displayed. This facility is intended for use if the helicopter unexpectedly flies to a location without a Data Retrieval Unit.
- Status - The Computer Unit will automatically monitor the log values against a table of critical values for each log entry. These entries will then be transferred to the Status Log. This function will be used by the Pilot as for a pre/post Flight check.

#### 6.4 Data Transfer Unit (DTU) (Fig 7)

The Data Transfer Unit is plugged into the computer unit by a separate connector. Using the DTU it is possible to access all of the data stored in the computer. By inserting a security key it is also possible to re-datum any of the stored values (eg. at an engine change). Certain parts of the status check function and the vibration analysis can also be altered using the DTU. The unit may be connected to an RS 422A or RS 232C compatible printer and print out with suitable headings and data identifiers can be produced. Alternatively it can be connected to a ground-based computer system and data dumped at 9600 baud.

The DTU has a Motorola 6809 microprocessor which can be programmed to examine data for longer term trending etc. Exact facilities of the DTU and ground-based system can be tailored to meet a customer's requirement. It is intended that comprehensive data bases relating to customers aircraft will be maintained by Westland.

#### 6.5 System Sensors

The majority of the input parameters required by the HUM computer for usage monitoring of both engine and transmission are available by suitable interfacing of cockpit instruments.

Major additional items are:-

- 1) Tail Torque-meter
- 2) Rotor-head monitoring system
- 3) Accelerometers
- 4) QDM system

Items 1 and 2 which form parts of the same system are produced by EEL (part of Westland Technologies Group).

For both areas strain gauges are bonded onto the rotating components and the strain signals passed as frequency modulated signals to the stationary part using capacitive coupling, the power for the rotating component being by inductive coupling. Using control channels the power transmitted is optimised, ensuring good EMC performance. There are four data channels - main rotor flap, lag, control, and tail rotor torque.

The accelerometer selected for the Series 300 has an integral charge amplifier giving obvious weight and cost advantages relative to either remote charge amplifiers or expensive cabling. This type of accelerometer cleared to the possible soak-through temperature of 150°C have only recently become available.

The QDM system, which is extended to all gearboxes in the Series 300 has been comprehensively described elsewhere (ref 7).

## 7. SYSTEM DEVELOPMENT AND CERTIFICATION

7.1 Certification of the system can be divided into four areas:-

- i) Software certification of HUM computer
- ii) Benchmark validity checking of software in actual hardware
- iii) Compatability checking of all HUM system components
- iv) Validation and long term proving of total system.

7.2 The software of the HUM computer is categorised as "essential" as defined by CAA Airworthiness Notice 45(5) and RTCA DO-178(6). This level has been adopted after discussion with CAA and ensures a high level of confidence in the software employed.

7.3 In order to test the software integrated into the hardware all of the inputs are stimulated with signals of known resultant usage etc to test all functions of the unit including signal validity and stability. Vibration inputs and Rotor Strain inputs of known result will also be fed in to check these functions.

7.4 Two development aircraft are to be used for the Series 300 Flight Trials programme. Both of these will be fitted with complete HUM systems and will accrue more than 300 hours of flying. During this time it will be possible to check the compatability of the HUM system components and also to check the HUM system calculated results against those reasonably expected.

7.5 In order to achieve full certification and maturity of the Series 300 dynamic components a Transmission Maturity Rig (TMR) is to be used.

The TMR is a tied down strengthened airframe and is completely computer controlled.

The TMR will be running shortly in its Series 200 configuration. During the 800 hour maturity run the TMR will also be utilised to develop the vibration monitoring facility of the Series 300 computer.

In its Series 300 configuration the TMR will include all of the HUM system components. Overnight when the TMR is not running, the computer will be used to calculate all of the usage values for the previous day's running. Thus on a day by day basis the calculations of the HUM computer can be validated using the TMR control computer.

Using the four aspects detailed above it is expected to certificate all of the HUM system algorithms and the system itself in parallel with the certification of the aircraft during 1986/1987.

## 8. CONCLUSIONS

The system described represents the first on-board health and usage monitoring system on a helicopter that offers a realistic "on-condition" removal and retirement capability for all dynamic systems. Such a system offers a significant contribution to the improvement of helicopter airworthiness, the current general level of which in the Western World gives cause for concern in a recently published review by the ARB (ref 1.) The system also offers considerable commercial benefits in terms of maximising component lives within flight safety constraints, reducing pilot and maintenance crew workload, and acceleration of component maturity programmes. Many of the facilities included in the Westland 30-300 HUM are demanding in terms of system reliability, data acquisition and processing rates, and accuracy of algorithms. Much experience of all aspects has been gained from the systems installed in the current production and development versions of the Westland 30 and Sea King helicopters; strain-gauge torquemeters on Scout, Wasp and Wessex helicopters; and a wide range of component rig tests, many of which extend to deliberate failure of the test component. The W30-300 HUM system utilises proven techniques implemented within current technology whilst retaining scope for further expansion of facilities.

## 9. REFERENCES

1. H.A.R.P Review of Helicopter Airworthiness, CAP 491, Civil Aviation Authority, London, June 1984.
2. D G Astridge and J D Roe, Health and Usage Monitoring in Helicopters, Paper 38, 9th European Rotorcraft Forum, Stresa, September 1983.
3. P S Grainger, Helicopter Data Acquisition in WHL, Paper 12, AGARD SMP Specialists Meeting, Siena, April 1984.
4. E E Martin, AIA Project Group for Helicopter One-Engine-Inoperative Ratings, Paper 83, 9th European Rotorcraft Forum, Stresa, September 1983.
5. Civil Aviation Authority, Airworthiness Notice 45, Software Management, Issue 1 November 1983.
6. Radio Technical Commission for Aeronautics, DO-178 Software Considerations in Airborne Systems and Equipment Certification, May 1982.
7. D G Astridge, Health Monitoring of Helicopter Gearboxes, Paper 7.3, 8th European Rotorcraft Forum, Aix-en-Provence, September 1982.

FIGURE 1 WESTLAND 30-300 HEALTH AND USAGE MONITORING SYSTEM  
BLOCK DIAGRAM

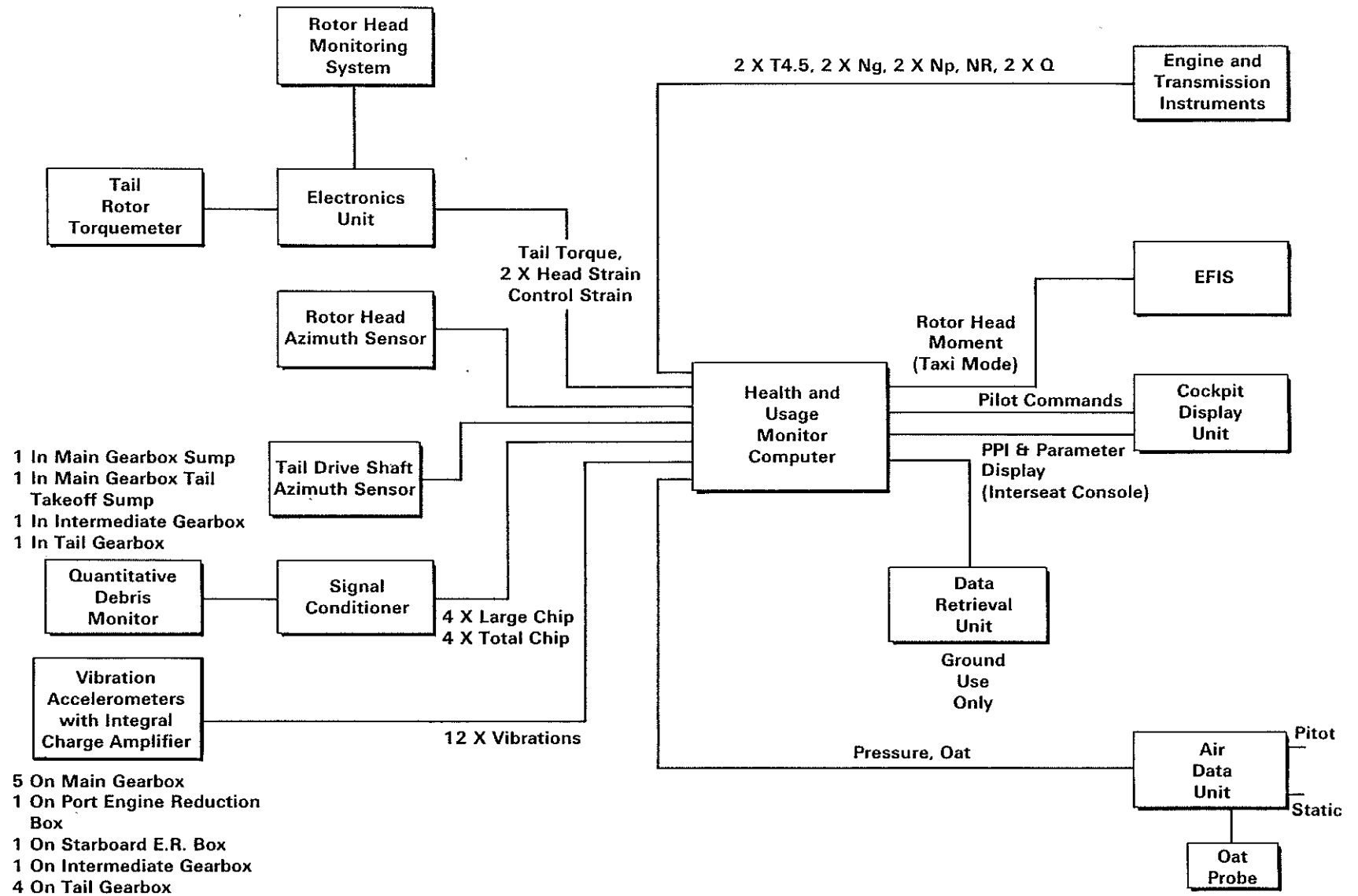

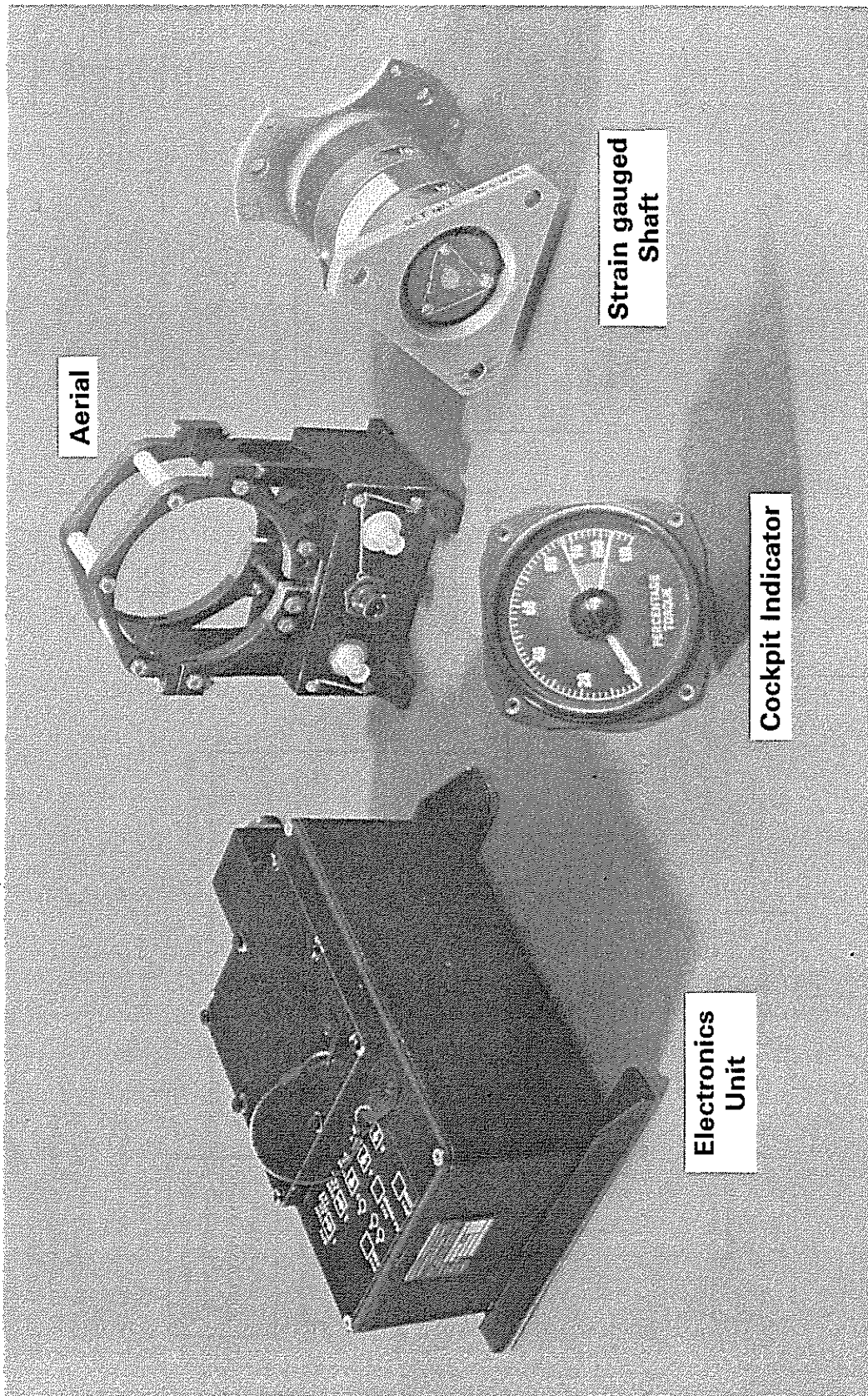

FIGURE 2 EEL TORQUEMETER SYSTEM FOR TAIL ROTOR DRIVE SHAFT

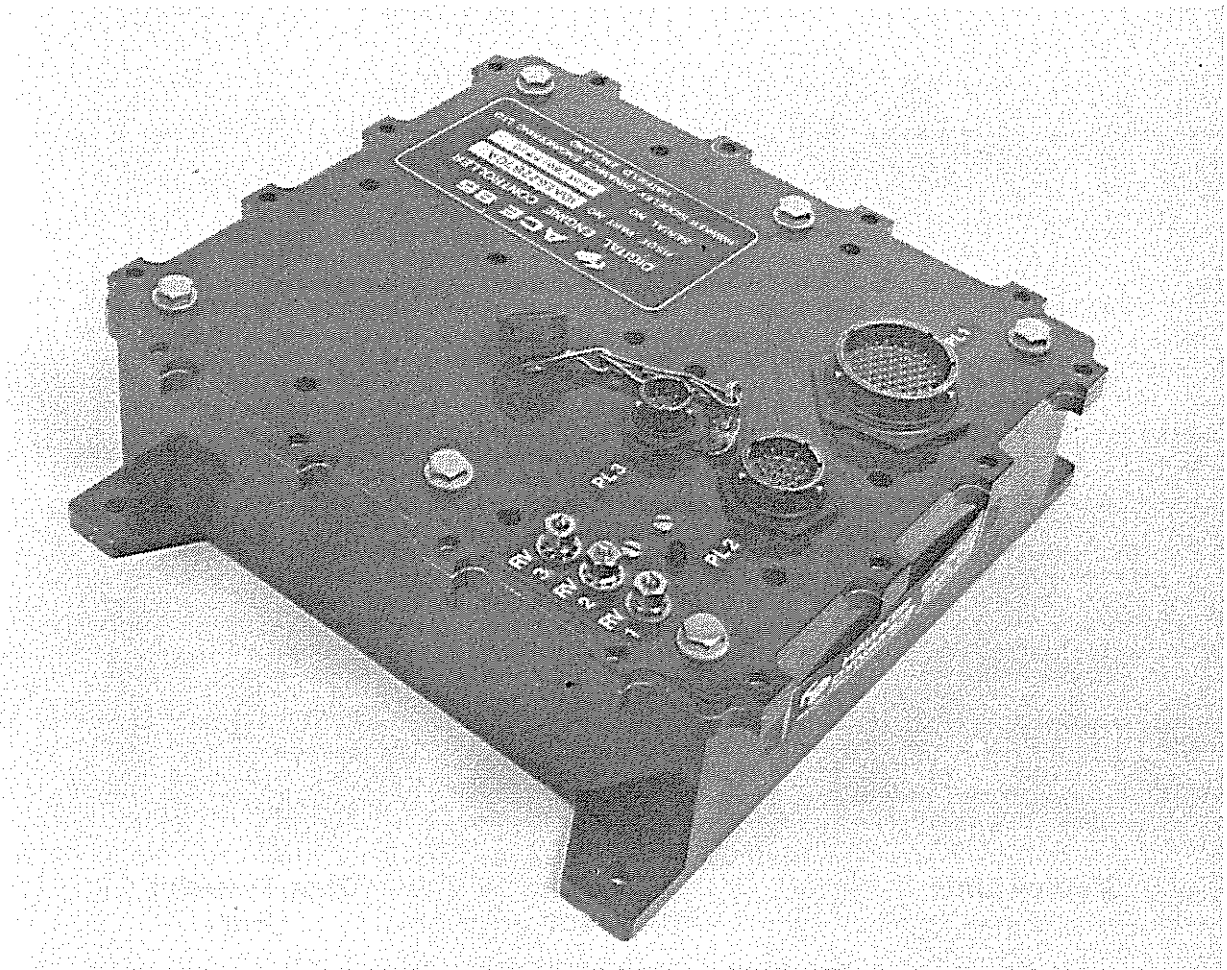
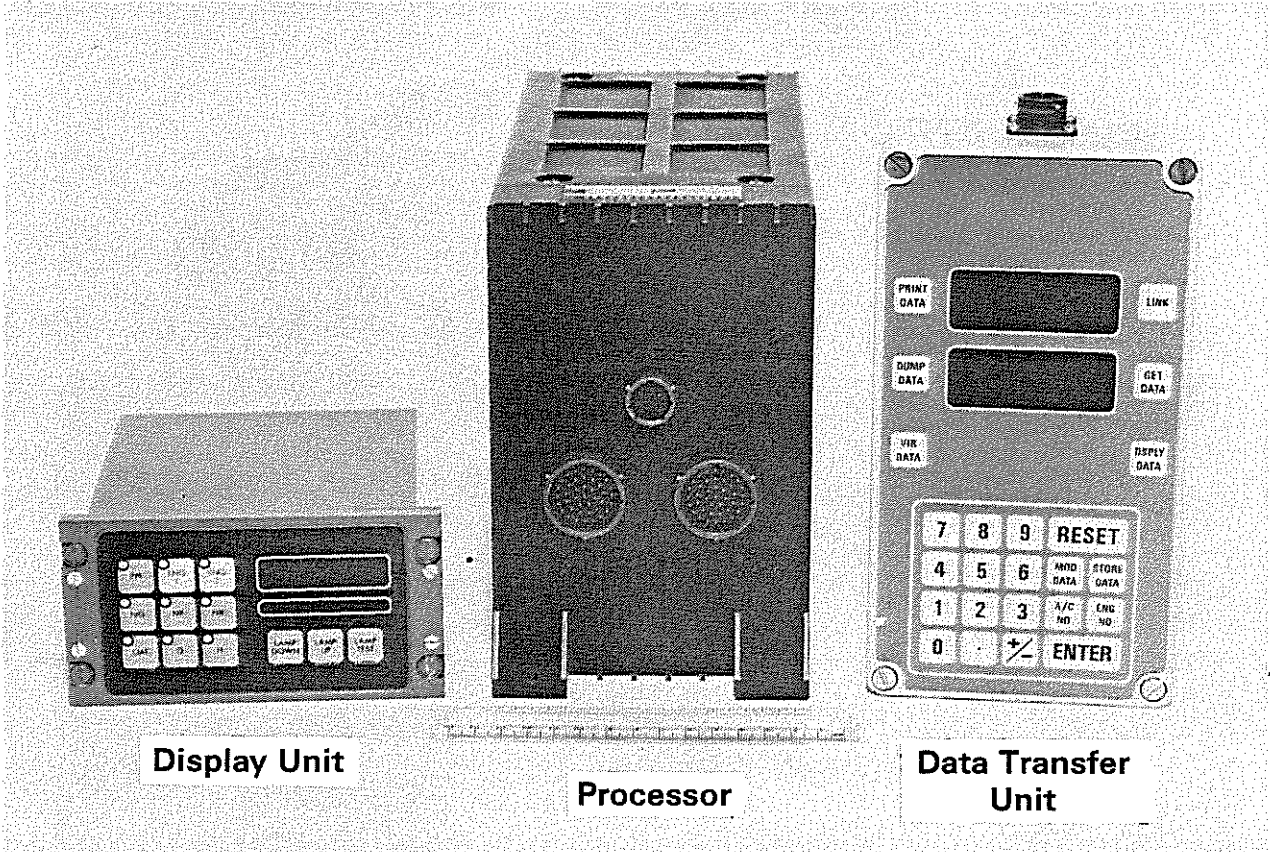

FIGURE 3 'ACE-85' TORQUE PROCESSOR  
Produced by Hawker Siddeley Dynamics Engineering Ltd  
and used on a development Sea King Helicopter





**Display Unit**

**Processor**

**Data Transfer Unit**

**FIGURE 4 WESTLAND 30-300 HUM HARDWARE  
Produced by Smiths Industries**

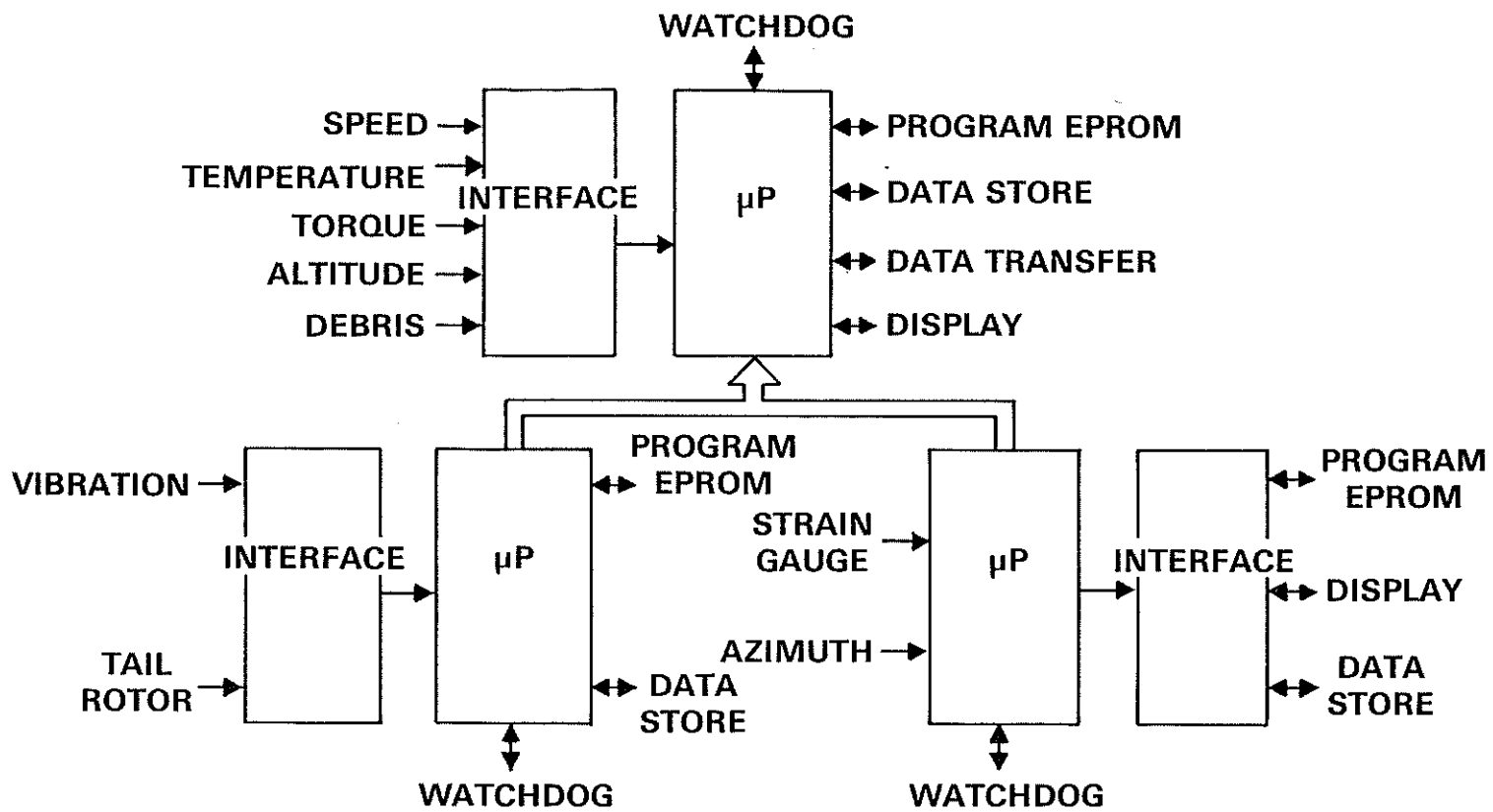

FIGURE 5 WESTLAND 30-300 HUM COMPUTER BLOCK DIAGRAM  
(Smiths Industries)

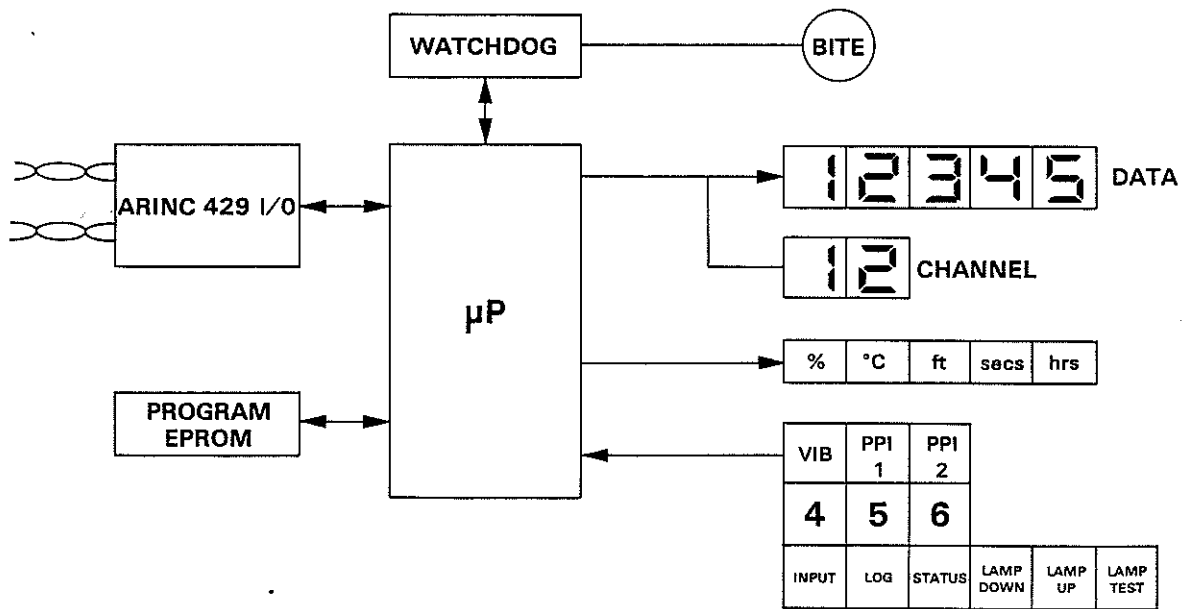

FIGURE 6 WESTLAND 30-300 HUM COCKPIT DISPLAY UNIT BLOCK DIAGRAM  
(Smiths Industries)

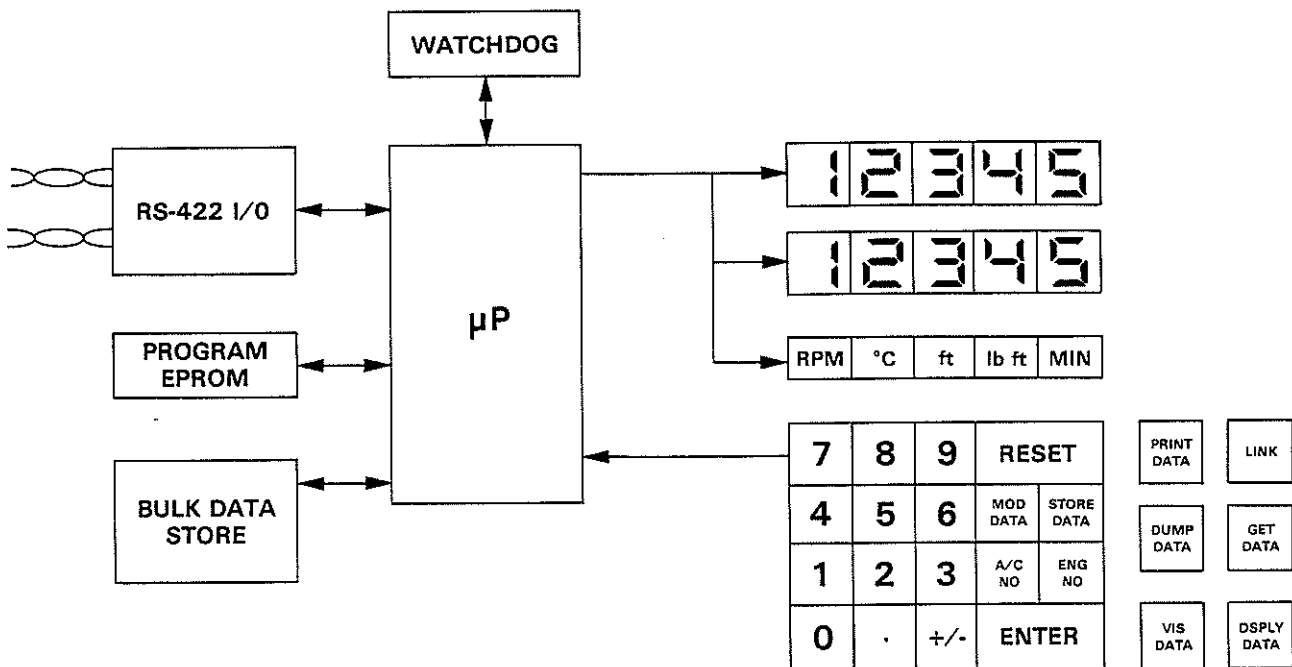

FIGURE 7 WESTLAND 30-300 HUM DATA TRANSFER UNIT BLOCK DIAGRAM  
(Smiths Industries)