

Sixth European Rotorcraft And Powered Lift Forum

Paper No. 42

**REAL TIME ANALYSIS FOR HELICOPTER
FLIGHT TESTING**

Ken Lunn

**Boeing Vertol Company
Philadelphia, Pa. ,U.S.A.**

&

James L. Knopp

**Boeing Computer Services
Philadelphia, Pa. ,U.S.A.**

Sept. 16-19,1980

Bristol,England

Real Time Analysis for Helicopter Flight Testing

Ken Lunn

*Manager of Experimental Operations
Boeing Vertol Company, Philadelphia, PA*

AND

James L. Knopp

*Senior Computer Specialist
Boeing Computer Services, Company, Philadelphia, PA*

Abstract

During the experimental or developmental testing of a new or modified helicopter configuration, the rate at which the test program can progress, both in terms of flight envelope expansion or the identification and resolution of significant problems, has often been constrained by data analysis flow times. The advent of magnetic tape recording, pulse code modulation (PCM) and telemetry has increased the number of measurements which can be made and the volume of data which can be gathered. Data handling, processing and analysis however, has frequently caused "bottlenecks" in the process of assimilating this data. At the Boeing Vertol Company, together with Boeing Computer Services, we have developed a real time data system, which is based on a large scale real time oriented Xerox central processor with a capability to provide on-line analyses unmatched in the Helicopter Testing Community.

This paper will discuss, primarily from the using engineer's viewpoint, the development of this system to the current capability which includes:

- Calculation of critical component alternating loads and rotor system critical damping ratios for envelope expansion.
- Harmonic and spectral analyses for vibration investigation and development
- Non-dimensional power required curves available at the conclusion of a level flight speed sweep or hover test
- A data base of calculated data, which resides on the processor disk storage for all flights in a test program (or

programs). This data base provides for fatigue damage calculations to be executed across multiple flights by simple terminal access, allows cross-flight data plotting and generates load plots for final reports.

Also summarized will be the increases in productive flight rate, data turn-around, test team involvement and extension of the data base to the areas of dynamics, performance and flying qualities.

The paper concludes with a description of the work currently in progress to further extend the capability of the system to replace photographic or Kine' theodolite techniques for Height-Velocity, Take-off and Landing and Airspeed calibration tests, in conjunction with spatial positioning hardware on board the aircraft. Also discussed will be work currently in progress to complete the flight loads analysis task by applying the fatigue damage incurred at specific flight conditions to the aircraft mission profile in order to determine component lives, together with our studies for future development.

Introduction

The Boeing Vertol Company has been involved with the usage and development of real time data systems since the early 1960's. Our first attempts involved the use of a CDC 3100 computer and our initial objective was to produce tabulated data, thirty minutes after the conclusion of a flight test. In this discussion of "real time data systems", we should recognize the fact that the evolution of this type of system has been a parallel effort between the on-board data acquisition and ground based data processing systems and we should also, define what we mean by "real time". It is obvious that in any system whereby physical phenomena must be transformed to an electrical quantity,

Presented at the 6th European Rotorcraft & Powered Lift Forum, Bristol University, England, September 1980.

conditioned, merged, transmitted to the ground, sorted and converted to engineering units prior to computation, analysis and display some delay is involved. At Boeing Vertol we have not attempted to assign finite numerical values in the delay which we consider acceptable since the complexity of the analysis and the importance of obtaining the required information before proceeding to the next test point, are a function of the criticality of the test being conducted. Instead, for our own purposes we define "real time" as:

- "Within a time frame consistent with an orderly progression from test point to test point within a single flight, with calculated engineering values available to ensure flight safety and the validity of the test point flown."

From the above it can be seen that we will accept the availability of engineering values (such as temperature, pressure or component loads) which vary from imperceptibly simultaneous to a delay of minutes (for say the calculation of critical damping ratio during aero mechanical stability tests). In actual fact the longest delay, currently, is the latter case which is approximately one minute from the time at which the excitation is stopped to final answer.

The evolution to our present data system in this 20-year period has progressed from oscillograph recording, frequency modulated analog tape recording to programmable pulse code modulation (PCM) digital recording and telemetry from the aircraft, complemented by data-handling techniques which have progressed from colored pencils and hand analysis to large scale, real time computer analysis. Our experience with various data systems leading up to current generation data processors or analyzers such as the Grumman Automated Telemetry Station (ATS) and the Boeing Simulation and Test Analysis in Real Time (STAR) has convinced us that the only effective real-time data processor is one which performs computational analyses on-line and presents engineering information in a form which can be compared directly with predictions.

The data analysis system currently in use at Boeing Vertol is based on a Xerox Sigma 9 central processor with associated Sigma 3 preprocessors, a Sigma 3 display processor, and special purpose equipment for converting digital counts (PCM data) to engineering units. The system has the capability to handle up to 512 parameters from each of two test aircraft simultaneously, access this data and perform computations and analyses for a variety of technical disciplines, and display this data with little or no perceptible delay after a test point has been flown. Concurrent with the development of the ground-based data system, we have developed small PCM systems which can be mounted on the rotor; this has allowed us to operate with an all-PCM data system with all

measurements being telemetered to the ground. The STAR is a multi-purpose system which, in addition to performing all data processing for flight test, is used in conjunction with the flight controls simulator, for background engineering batch processing and remote terminal job entry (TJE).

In attaining the amount of telemetered data we can now process, the analyses we can perform, and the recall capability of the data base, we have begun to encounter system capacity limitations. Furthermore, during periods of intensive flight test activity it has become difficult to find system time for simulation, batch processing, and TJE. We have, in the process of working with the system, formed opinions on what could be done to alleviate this situation. These recommendations are discussed in this paper.

Development of the System

Overview

The development of the current real time data system at Boeing Vertol has really been a parallel activity in the development of both airborne data acquisition systems and ground station processing. Until the early 1960's the primary method of recording and processing flight test data was the oscillograph, and the primary method of transferring transducer signals from rotating components to the record system was by slippings.

During the Sixties we introduced on board the aircraft, Narrow Band Frequency Modulated (NBFM) tape recording and multiplexing techniques together with rotor head signal conditioning and automatic analog to digital conversion in the ground station for data processing. Since we were telemetering 14 channels of FM data to the ground during flight, we attempted to use a CDC 3100 computer and a 48 channel analog to digital converter as a pseudo-real time system. The object here was to produce, thirty minutes after the flight ended, a tabulation of the alternating and steady loads for critical components. While this system attained some degree of success, it was not widely utilized due to fall off in the flight test workload and the initiation of a cost reduction program. As part of this cost reduction, the flight test organization was moved from Philadelphia International Airport to much smaller quarters in the main complex at Ridley Park. The CDC 3100 was stripped of many of its peripheral devices.

In the mid 1970's we were awarded a contract for the competitive development of the prototype UTTAS helicopter (YUH-61A). This program required the development of a new airframe and integration of a new engine in a time frame considerably shorter than the normal development/qualification cycle. The flying of qualification test conditions can be generally accomplished quickly and the data analyzed later. But if the development cycle is to be timely, the flight program should not be constrained by delays in

obtaining data. Prior to this competition, our on-board data acquisition systems had used analog recording techniques. With this type of on-board data package the amount of data which can be telemetered is generally restricted to one FM track (or approximately 15 channels). The request for proposal required each contractor to install a PCM data package for the Government Competitive Test (GCT). Although the Army required fewer PCM data parameters than Boeing Vertol needed for the development phase, we elected to employ the PCM capability to the maximum extent possible. The frequency response requirements from the main and tail rotors on the YUH-61A were such that it was not feasible to record and telemeter all these parameters on the PCM stream. We used a hybrid PCM/FM system which allowed us to telemeter all PCM channels plus 15 FM channels, although we had a capability of measuring 60 channels on the main and 30 channels on the tail rotor.

Probably one of the keys to our success in real time data analysis and one which has been over-shadowed by the accomplishments of the ground based computer is the effort we made in design changes to the on-board data acquisition system. We have previously noted the use of sliprings to pass signals from rotating components to the recording system in the cabin. Starting with the UTTAS program, we completely redesigned our rotor head data packages. The change that we made was fairly radical, in that we elected to signal condition and multiplex, (at the rotor head) all main and tail rotor measurements and transfer the data across a rotary transformer in much the same manner as a telemetry signal. This multiplexed signal was then discriminated and re-multiplexed to form a composite of main, tail rotor and fixed system measurements prior to transmission to the ground station. The on-board PCM system used solid state switching controlled by programmable chips so that the units could be interchanged between test aircraft having different formats and sampling rates.

At the time, our background in PCM recording techniques and the processing of on-line PCM data was limited, and we decided to conduct the test program from Calverton, Long Island, using the Grumman ATS. The ATS served its purpose for the flight test program and also taught us some lessons in how a helicopter-oriented data system should be designed. In processing data the Grumman ATS has a three stream capability and allocates approximately one-third of the core, after housekeeping functions are met, to each of the three streams. For helicopter applications where frequency response requirements (sampling rates) are approximately five times those required for fixed wing applications, the fixed-time-segment analysis is not as effective as the priority interrupt approach used in the Xerox Sigma 9 Naval Air Test Center Real Time Processing System (RTPS) and the Boeing Vertol STAR. With the Grumman ATS we were unable to develop a rotor stability analysis

program due to the high sampling rate during data collection.

Since we had already purchased a Sigma 9, central processor for use in the flight simulator laboratory, we contracted with Xerox Data Systems to install basically the same system which they had developed for NATC. Due to funding limitations, the peripheral equipment was initially constrained to a single telemetry stream operation.

The system was first used on a Boeing Vertol BO-105 experimental test program to investigate a rotor isolation system (IRIS). This aircraft first operated with only 15 channels of FM data being telemetered to the ground; a PCM system was added at a later stage with a maximum of 60 parameters. The only analysis program available was a harmonic analysis routine used to plot N/rev content of accelerometers in real time. This program has been in continuous use since it's inception with only minor modifications. This first use of the real time system, while limited to relatively few parameters and one analysis program, served it's purpose and proved out the Boeing STAR laboratory. Toward the end of this program, we delivered the three U.S. Army YUH-61A aircraft to the GCT and moved our Company Owned Prototype (COP) from Calverton to Ridley Park (Philadelphia) to continue the vibration development program using the *Star Lab*. This aircraft had a hybrid (PCM/FM) telemetry stream. For this program we developed a safety of flight stress analysis program for real time use (SEVAL). This program has also been in continuous use, with only minor modifications, for real time monitoring for all subsequent developmental flight testing. The effort to use the in-flight recorded component loads to arrive at final component lives has gone through a series of iterations. While the program and system changes we made served the purpose of the test program, the experience gained convinced us that we should free ourselves from the 15 channel FM limitation and the manipulations required to merge FM and PCM data in the computer.

In 1977, we increased the on-line analysis capability of the system to include aircraft performance testing. The program calculates corrected referred power based on rotor shaft torque, engine torque, fuel flow, gas generator speed and turbine inlet temperature.

At the start of a flight, various constants and initial aircraft conditions are input to the program from stored control files to describe the particular helicopter model and specific aircraft calibrations. These include: ambient conditions, initial gross weight, fuel density, transmission efficiency, drag due to external instrumentation, etc. By option selection, the program will correct for free air temperature recovery (fwd flight) or correct cable tension for cable angle, deviation from the vertical for tethered hover flights.

When the program is running, a sampling routine accumulates a sum and sample count of all data samples. The performance program accesses this data block once per second to generate time histories of: cable tension, pressure altitude, indicated airspeed, forward and aft rotor torque, engine torques, fuel flow and rotor speed. These time history plots can be displayed on the PES for the test director's evaluation that fully stabilized data is being accumulated at each test point. At the end of a series of events which have been accepted as valid, the program prints a summary of all performance parameters by event and displays an X-Y plot of non-dimensional power required versus non-dimensional airspeed (level flight). The calculated values can be entered into the data base for storage of all performance data in a program or programs and can be accessed later from a terminal or the PES without the need to re-process the original data.

For the CH-46 Fiberglass Rotor Blade (FRB) program we purchased small PCM encoders which could be installed in the rotor packages. At the same time we deleted the rotary transformer and reverted to sliprings since the transformers could not pass the square wave required in the PCM stream. We have found that when operating with real time analysis systems it is essential that team planning for all hardware, software, and test objectives be completely integrated and very thoroughly executed if the program is to be successful. For our first attempt at an all PCM data system, we were, unfortunately not as thorough as we should have been; and we were plagued with excessive telemetry system signal dropout. Later when we tried to process the airborne tapes through the SALT stress alternating loads program, the task was laborious due to noise spikes on the PCM which the analysis program interpreted as extremely high loads. The applications program changes, including a "wild point edit" routine for the CH-47C FRB and YCH-47D programs are discussed in the software section of this paper.

These changes, together with improvements to the automatic tracking telemetry antennas and some re-design to the main aircraft PCM unit eliminated the PCM "spiking" and processing problems. The only problem remaining was the high rate of failure of the rotor head package power supplies and some manual steps in applying fatigue damage to the mission usage spectrum to determine component lives. Other changes we have made since initiating the system have been the incorporation of a two stream capability (1977); and in 1979 when we built our new Flight Test Facility in Wilmington, Delaware, we added a remote capability to access the computer from the test site. For our commercial Chinook (Model 234) certification program, we have again re-designed the rotor head packages and developed additional software to complete the stress analysis tasks through the *Star Lab* computer. The development of the airborne and ground station data systems are summarized in Table I.

Data Base Development

The original purpose of the present data base of stress and performance flight data was to allow the production of a large volume of plotted stress loads for final reports. One major difference between the normal maneuver oriented plots and the the loads report plots is the requirement to merge data from many flights on the same plot grid. The flight results data base today is still heavily stress loads oriented. Performance and flying qualities data has also been included from more recent flights. Future expansion will include vibration data. The data base is still growing and now occupies 40 million characters of disk storage. Utilities are available to access data by:

- *Aircraft Name*—all or specific flights
- *Flight*—all or specific events
- *Maneuver Code*
- *Measurement Name*—alternating, steady, fuel flow, etc.
- *Process type*—Stress, Bruhn, Performance, etc.

Concurrent access by several users can be via batch process, interactive terminals, or during a flight. For example, the flight test engineer can compare his current data results from a flight with similar data from other flights and other aircraft. These trend comparisons can be plotted as multiple traces on the same grid. Utilities are available for :

- *Plot Recall*— through the flight system or CalComp plots
- Listings and other sorted comparisons
- *Correction* of values and descriptive items
- *Fatigue Damage* assessment of individual events or component life evaluation
- *File Maintenance*

Component loads summary and part life determination are recent applications of the data base. Computation of a part life has previously been a labor intensive process requiring data to be evaluated against a comprehensive aircraft mission usage spectrum profile. Evaluation of such conditions as ground—air—ground cycles require the data from an entire flight. Pre-requisites to automating the part life evaluation have been

- *Engineering Development* of part life methodology
- *Machine Readable Stress Data* available from many flights in an efficient randomly accessible form—i.e., a data base.

In some applications results already present in the data base control the processing in a related program. Stress evaluation program (SEVAL) results in the data base are used to signal which measurements in an event exceed their endurance limit and require a

Airborne System	Ground Station	Telemetered Data	Real-Time Processing	Batch Processing	Turnaround Time	Staff Size
Recording oscillograph	Stripout	12-channel NBFM (PBW)	Hand analysis	Punch card input to IBM 650	3 weeks	40
NBFM-magnetic tape	Automatic analog-to-digital conversion -CDC3100	12-channel NBFM (PBW)	Hand Analysis	Digital tape input to IBM 7044, IBM 360	1.5 weeks	20
NBFM and PCM – magnetic tape	Grumman automated telemetry station	All PCM- 15-channel NBFM (CBW)	Computer real-time analysis-parameter limited	Digital tape input to CYBER 73	5 days	10
PCM – magnetic tape	Boeing STAR Laboratory	All data	Computer real-time analysis: <ul style="list-style-type: none"> ● Stress ● Dynamics ● Flying Qualities ● Performance 	Interactive from disk files	1 day	6

Table I. Development of Airborne and Ground Station Data Systems

Bruhn cycle count analysis. Bruhn analysis is operated only in the background batch processing mode. The SEVAL data may have originated either in the off-line batch analysis or during flight in the real time analysis. Basic aircraft parameter values such as RPM, airspeed, and running gross weight are captured in real time for the data base and accessed by both SEVAL and Bruhn analyses later.

Description of the System

Airborne

The basic elements of the airborne data acquisition system for the Model 234 Commercial Chinook are shown in Fig. 1. A brief description of each element is given below.

The rotor head packages for each rotor are identical and consist of signal conditioners, amplifiers, a circuit board type PCM system with plug-in filters and a slipring to provide power from the instrumentation rack in the cabin and to transmit the PCM stream to the main PCM unit. This package is re-designed for this program and was considered necessary to eliminate the power supply failure and noise on the PCM which was experienced on the YCH-47D

program discussed earlier. The improvements remove the power supplies from the package to a more stable environment, increase the signal level being transferred back to the rack from 10 millivolts to approximately 5 volts, provides miniturized, easily interchangeable filters and provides an all connector hook-up in place of the patching system used earlier. This system was designed and built in the Boeing Vertol Flight Test Instrumentation Laboratory and uses no vendor developed equipment other than the slipring and signal conditioners.

The main instrumentation package contains the patch panel used to route transducer signals from all parts of the aircraft to the signal conditioning (except for rotating parameters), the main PCM unit and the telemetry transmitter. The rack also contains built-in test equipment for parameter checkout, although the basic flight to flight validation of the airborne data system is accomplished via the microwave link to a Hewlett-Packard computer in the instrumentation laboratory. From the PCM unit the stream is routed via the telemetry transmitter to the ground station.

During all real time analysis flights prior to the Model 234, the *Star Lab* computer has calculated basic aircraft parameters for continuous display on the Project Engineer's Station (PES) CRT video display

and for access by all analysis programs . Our basic aircraft parameters are up to 41 in number and include such parameters as current gross weight and center of gravity, true airspeed, density altitude, advance ratio and rotor thrust co-efficient (C_T/σ) etc. We also display to the pilot in the cockpit non-standard displays for test purposes. The on-board computer calculates these values for display in the cockpit and frees up a significant portion of the ground based computer for other analysis tasks by telemetering the calculated values rather than the raw data. The new equipment also provides a new single unit display panel to the pilot which can be programmed and formatted to display up to 8 parameters. Five formats can be programmed for selection by the pilot.

Ground Based System

Figure 2 shows an overall schematic of the system including the telemetry antennas, the main computer center and the remote terminals at the Wilmington Experimental Flight Test Facility. The telemetry signal is detected by either fixed antennas located on

the flight test hangar at Wilmington or the main tracking antennas at Ridley Park and transmitted by microwave link to the main computer facility. The incoming telemetry signal passes through the front end of the ground station to the computer and final data is transmitted by microwave link to the terminals at Wilmington. A brief description of each element as they are used sequentially follows.

Main Ground Station

the PCM incoming signals are routed from the Signal Selector Panel to either Stream 1 or Stream 2. The data is fed into a Monitor 317 Bit Synchronizer and a Monitor 1126A PCM decommutator. The 1126A decommutator is computer controlled, receiving its decommutation program from the Sigma 9 central processor. This programmable decommutator may be configured to accept any desired combination of synchronization pattern, word size, frame length and subcommutation depth. During a flight, the telemetry signal is continuously recorded on analog tape from engine start until rotor shutdown. This is done to obtain a complete flight record in case of incident or accident to the test vehicle.

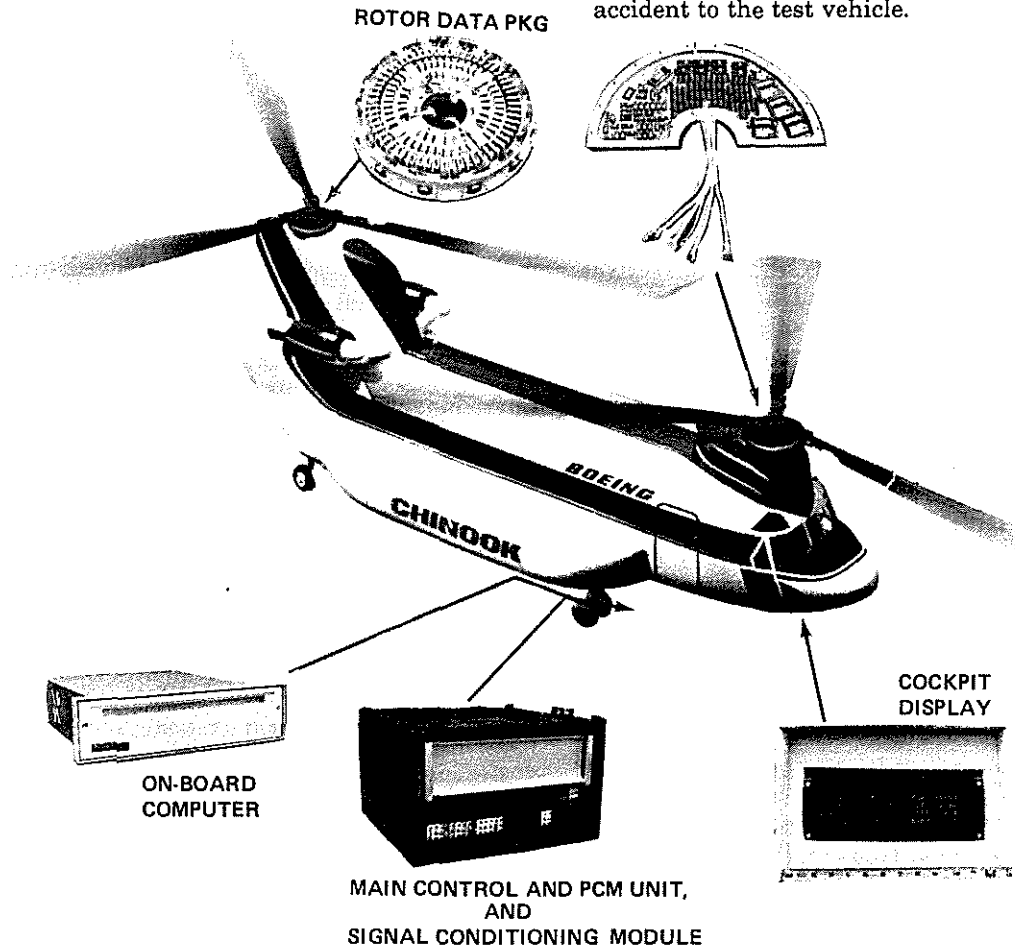

Figure 1. Model 234 Airborne Data Acquisition System

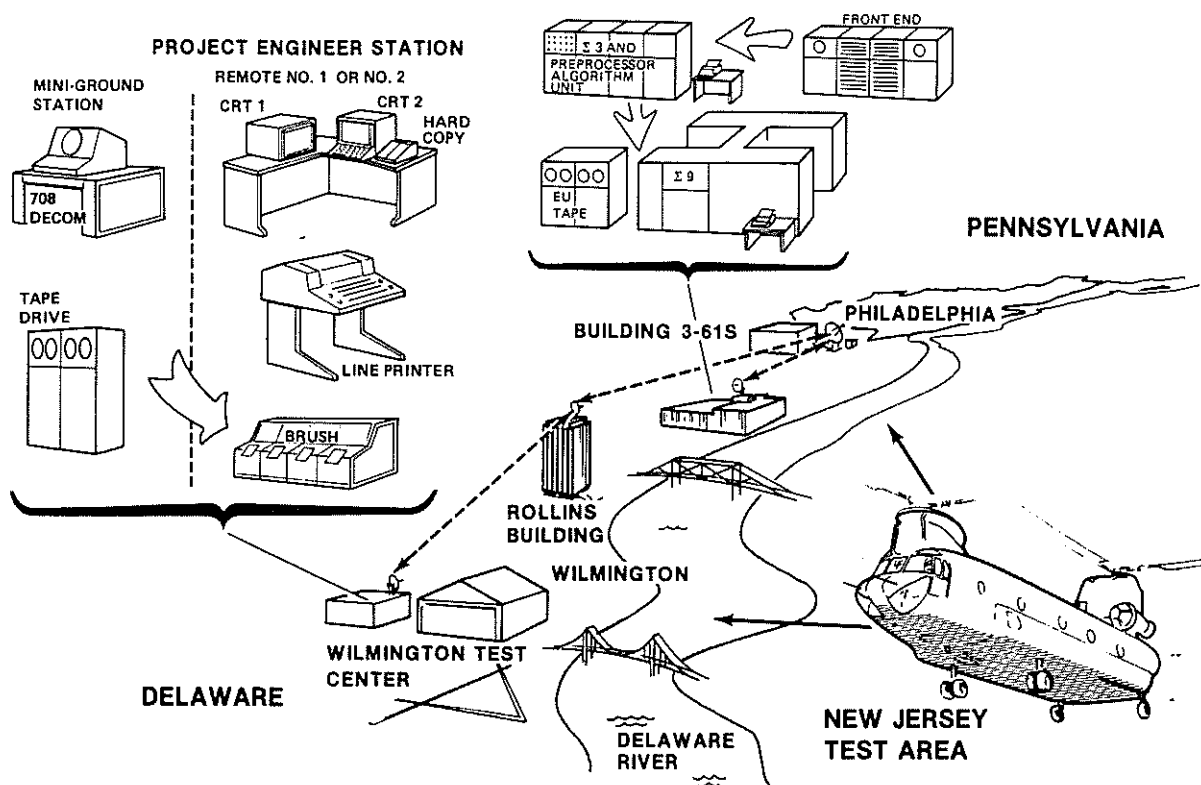

Figure 2. Ground Based Data System

PCM serial bit stream output from the Monitor 317 bit synchronizer is sent to a Xerox Sigma 3 computer operating in conjunction with a special purpose algorithm processor. This equipment provides linearization, engineering unit conversion and limit checking in less than 20 microseconds per measurement. Also the Sigma 3 creates the engineering units (EU) digitized magnetic tape for specific events that the PES operator elects to save for further analysis; either batch or real time. Up to 50,000 data samples per second can be continuously recorded.

From the Sigma 3, the data, converted to engineering units, is passed to the Xerox Sigma 9 computer. The Sigma 9 Control Program for Real time (CP-R) operating system is a highly efficient monitor designed specifically for real time applications. The Sigma 9 computer accomplishes all of the real time program analysis as well as the batch and interactive terminal analysis. The Sigma 9 also has the capability of outputting 32 parameters on engineering unit scaled brush charts per data stream. The brush table scaling is computer controlled and can be re-scaled by the PES operator during a flight.

Remote PES System

The remote PES System (REMPES), consists of a two way (duplex) microwave link which connects the main ground station at Philadelphia to the Flight Test

terminals at Wilmington, and a simplified schematic is shown in Figure . The main output of the Sigma 9 central processor to the PES consists of information to create plots and tabulations on a CRT, analog stripchart information and summaries on a line printer. In the main ground station, the analog output of the Sigma 9 (normally routed to the stripcharts) is passed through a PCM encoder to a multiplexer (TI). Only one port of a three port unit is used in this direction. The SMT multiplexer carries two way modem communications between the peripheral devices at Wilmington and the Sigma 9. The D3 multiplexer carries two way voice communications. The output of the three units is intermixed in a first level multiplexer and then microwaved to Wilmington.

At Wilmington, the signal is received, passed through three multiplexers identical to those used in the main ground station and routed to the voice communications equipment, the peripheral devices and, via the PCM decommutator, to the stripcharts.

In the reverse direction, the peripheral I/O's and voice communications are mirror images of the main station processes. The PCM data from the aircraft is received through the telemetry link, and after passing through the bit synchronizer is passed through the multiplexer/microwave link to the corresponding units in the computer lab. There it is routed through the Star Lab front end as normal PCM data from the test aircraft.

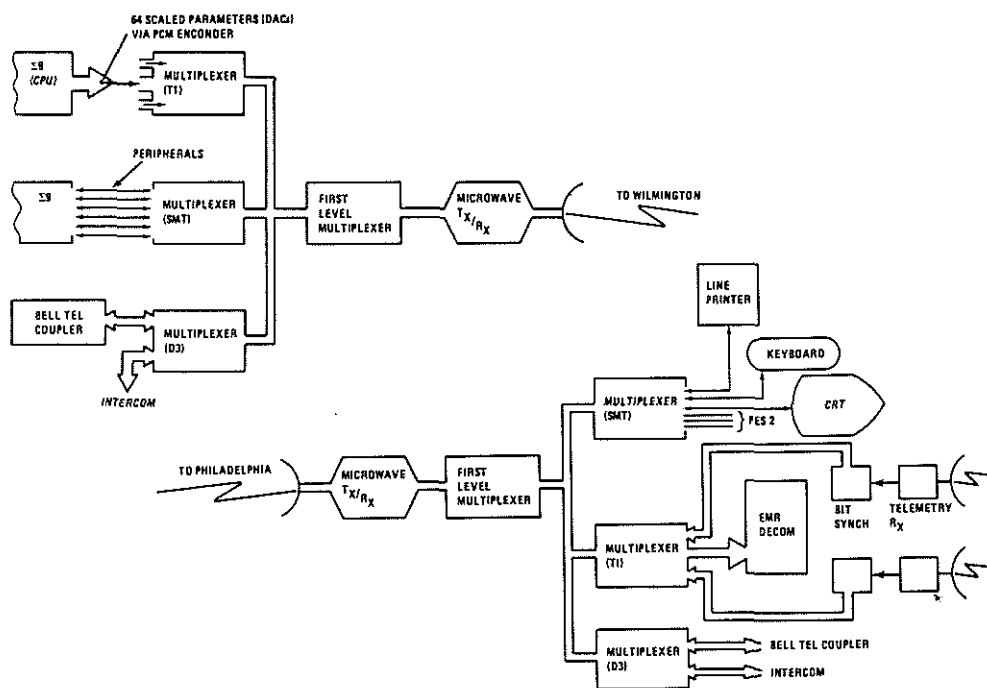

Figure 3. Simplified Schematic-Remote Pes.

Analysis Programs—Methods and Structure

Overview

The areas of primary engineering interest in flight data have been for—

- *Dynamics*-Transforms of time sampled data into the frequency domain are required for motion analysis, mode shape investigations and aero-dynamic stability computations.
- *Flight Loads Analysis*-Every sample is monitored to determine alternating loads and cycle counts for assessment of flight safety and fatigue damage.
- *Performance and Flying Qualities*.

Both vibration and stress data are characterised by relatively large numbers of transducers to analyse. The engineer may be required to choose from among desirable transducers those which he is most concerned with for analysis during flight. The chosen transducers are such that the flight can proceed from one test point to another with confidence in both flight safety and confidence that remaining data is being obtained. Decisions from one flight to another may require: additional transducers analysed after flight, additional plotted output from those transducers analysed in-flight, or comparison of data from a series of flights.

Post-flight processing is provided for in the *Star Lab* system. The application program never need consider the source of the data. With only minor changes in initial log-on procedures, the flight test engineer may use data recorded on 1) telemetry tape of voice, PCM, FM, and time code data, 2) on-board aircraft magnetic tape recorder, or 3) a digitized computer generated tape of engineering unit sample values. Comparison of data trends between flights can be a critical decision making tool for subsequent flights in a development cycle. To provide this capability on a timely basis requires that the calculated results be stored in a computer readable form. The processed flight data base addresses this need.

Later in this paper (Fig. 6) a maneuver menu is shown on which the project engineer has defined the programs of interest in his current series of flights. Multiple entries listing the same program are present for various combinations of plot groups which he has *previously defined using system utility functions*. The selections and specification of plot variables, scales, etc., is independent of the application program to allow the project engineer to optimize the plot grouping and formats for his particular series of flight.

Harmonic Analysis

The on-line harmonic analysis program allows the engineer to analyse during flight three selectable N/rev harmonics for each of 20 transducers. The resultant and phase angles can be plotted on demand

versus airspeed, RPM, time or themselves. As in most maneuver programs, the particular transducers, and harmonics analysed need not be specified until actual execution time. A program feature useful during flight development of vibration isolation devices calculates and plots the ratio of resultants and phase differences for pairs of transducers. Thus, the attenuation across any device can be graphically displayed. Program results are automatically directed to a "replot" file. This feature allows the engineer to regroup his plots or save plottable results for display after the flight without re-running the program.

Internally, the program is designed to acquire a fixed number of 64 data samples from each transducer, sufficient for computation of up to the 12th harmonic of the 1/rev period. The three specific inner summations of discrete Fourier transform for the selected harmonics are computed. By computing and storing the needed summation complex coefficients during program initialization, and using only the summations of interest, significant computation time is saved over Fast Fourier Transform methods. Savings in computational time (CPU bandwidth) are of concern in our system to optimize the overall response on both telemetry data streams.

Moving Block Dynamic Stability Analysis

The aeromechanical stability analysis program computes the system damping coefficient for either of two selectable transducers. The data acquisition function in this method is real time and spools all data samples to a file. The analysis function is performed between aircraft maneuvers, and due to extensive engineer interaction with the program, requires approximately one minute to complete. The transducers chosen are typically critical resonance indicators such as rotor chord bending or airframe acceleration.

The program assists the engineer by performing a spectral analysis on the timeslice of data he selects. The engineer chooses a nominal damping frequency to analyse by examination of the spectral plot. Because the frequency location of spectral lines in a discrete Fourier transform depend on the data collection period and total samples, the selected frequency may not be precisely at a mechanical resonance frequency. To compensate for this, the program adjusts the number of samples in use to maximize the response in an area near the selected frequency. The object is to force a spectral line to coincide with the actual aircraft resonance frequency.

The principle in computing the damping envelope response uses the characteristic of the discrete transform that implicitly assumes a stationary frequency content. The computed response of a non-stationary spectral component will exist in relation to its *average* value through the collection period. The relative change in spectral response at one frequency

can then be found by performing a series of transforms—each displaced in time by one or more samples. The transform order, i.e. blocksize, of samples remains constant. Using recursion formulae, only the response at the frequency of interest is computed.

The time series of damping results, non-dimensionalized to percent, in logarithmic form and referenced to the first resultant of the series are plotted for the engineer's inspection. The interval during damping tends to a straight line. The program computes the damping term as the slope of a straight line curve fit. The straight line least squares curve fit overlays the original damping plot for the operator to visually check the results. Extensive comparisons of the computed damping value with flight data has shown that extremely accurate results are obtained in the flight regimes of greatest interest: lightly damped, near resonant conditions.

Flight Loads Analysis (Real Time)

A prime objective of stress analysis in-flight is to ensure safety of flight and obtain data from which component part life may be determined. All components for which top-of-scatter loads determine fatigue damage may be acquired during flight. Complex cycle counting Bruhn analysis is also performed after the flight for those components where load histograms are needed.

In order to monitor each data sample of up to 32 transducers from the telemetry stream, computer operating systems level routines are used. This allows the application program to acquire the absolute maximum and minimum values occurring in an interval in snapshot form using very little CPU time, and therefore, low impact on other concurrent software functions. The program can automatically sense the start and end of maneuvers, or they may be signalled by the flight test engineer. In either case, the program produces time histories or cross plots of absolute minimum and maximum, alternating load, steady load, and percent endurance limit. Summaries of results for each event processed are available on demand by the flight test engineer. End of flight summaries are available listing results sorted by event for each transducer. Both plots and summaries can be produced during flight or afterward if more convenient. All results can be routed to the "replot" file and to the flight data base.

Post Flight Stress Analysis

The on-line real time stress analysis program is used to process up to 32 transducers of immediate interest to the conduct of the flight. An off-line batch program is used for bulk processing of up to 120 additional transducers in one pass of the program—a capacity normally sufficient to process all stress measurements of interest in a flight. The computations performed are similar to those in the on-line stress analysis. In the batch mode, however, more extensive checking can be

performed on the data. Like the on-line stress analysis, all results are suitable for loading into the flight data base. Telemetry signal dropout and instrumentation noise spikes from any source can degrade the data and lead to erroneous engineering conclusions and invalid fatigue life computations. Single sample errors, typically inconsequential in vibration analysis, can lead to changes in component life through invalid indications of fatigue damage. In the off-line program approximately one million data samples are analysed for every 45 seconds of aircraft maneuvers. Even very low error rates can result in many engineering hours troubleshooting suspect data.

An algorithm is included in the off-line stress analysis to detect and ignore single sample data spikes. The method used is similar to the effect of a rate sensitive filter. In any group of three samples, the first and last are used to interpolate a midpoint. The actual value of the middle sample must fall within a percentage range centered on the calculated midpoint. If the middle sample lies in this range, it is considered a valid sample. If the sample is outside the range, the sample is considered suspect. A possible bad sample is checked for rate of change in value compared to the previous sample. A change of more than 10% of the transducer bandwidth is used as the threshold for sample quality. The bandwidth change limits and window sizes were determined by the examination of the sampling rate with signals of varying bandwidth deviation in amplitude and frequency. Confidence limits of approximately 40Hz with 70% deviation were found to still produce correct wild point detection. This corresponds to a minimum of approximately 5 samples per cycle at the highest frequencies of interest.

Software Structure

Analysis programs may operate at one of two priority levels designated as the flight condition monitor level and the maneuver program level. Software execution priority levels are different for the two program types thereby allowing monitor functions—also priority driven—to proceed independently from the specific analysis functions. Both program types operate concurrently with the flight condition program receiving a higher execution priority. Software controlled scheduled delays are used in both types of program to ensure that the many other functions concurrently residing in the system have adequate opportunity for execution. The typical program logic for processing an aircraft maneuver is shown in Figure 4.

The software tasks concurrently operating in the system at any typical moment during a flight may include:

1. **Flight Conditions Monitor.** An application program computing basic aircraft parameters on a regular basis, e.g., airspeed, running gross weight, CG.

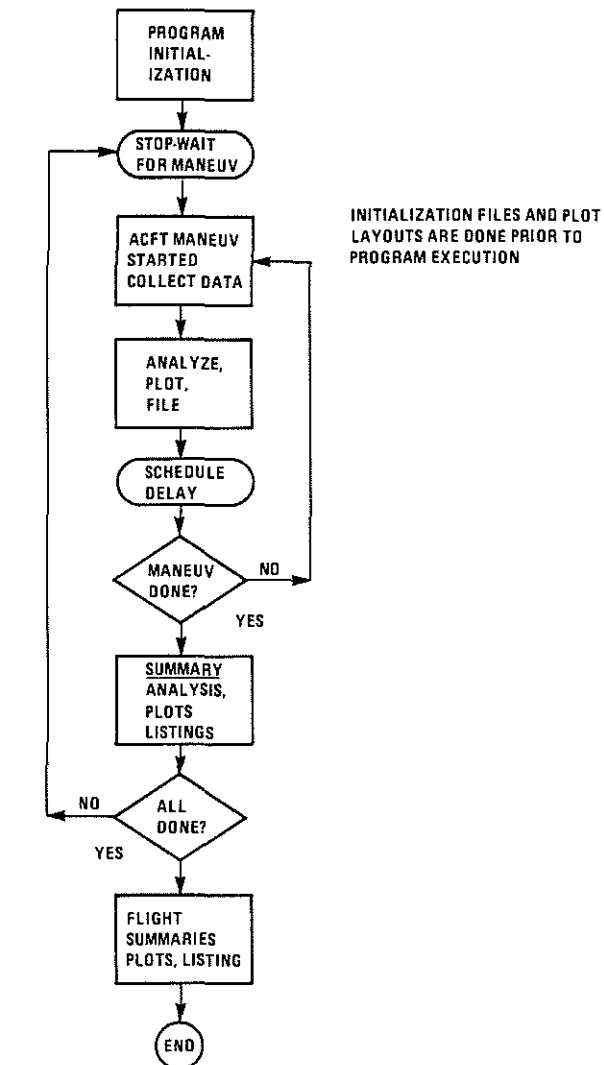

Figure 4. Typical Program Logic

2. **Maneuver Program.** An application computing specific values for which the flight is conducted, e.g., vibration or stress analysis, stability, performance.

3. **Stripcharts.** Up to 32 stripchart pens of computed values or engineering units from the telemetry stream at 300 samples per second.

4. **High Speed Data Scan.** A task used for monitoring telemetry values to determine maximum, minimum, averages, etc.

5. **Plot Control and Update.** A task which manages the data flow to the PES plot screens.

6. **I/O Control Executive.** A message switching task dealing with data transfers between the several programs, the operator, and the various CPU's in the system.

7. Selected Measurements Display. A monitor task scanning and updating selected computed or telemetry values on the PES screen each second.

8. Operating Function Options. A collection of many utility programs initiated on demand by the engineer for definition and control of engineering unit digitized tapes, absolute limit checking, maneuver programs, plot definition and display, control files and others.

A similar set of program tasks concurrently operates to perform the same functions for the second telemetry stream whenever that stream is in use. The system software load with both telemetry streams functioning has up to 36 software tasks concurrently in execution on a priority basis.

Plotted Output During Flight

As noted in the discussion of primary application programs, the principle output in the real time system for direct comparison to engineering predictions is plots. The system includes extensive software facilities for control of plotted output. In general, all data whether directly from the telemetry stream in engineering units, or from calculations in an application program has a name of up to 8 characters. Plotting may intermix any set of data names as either cross-plots or as time histories. The definition of specific plot formats and combinations of plotted data in a single display is reserved for the flight test engineer. The application program normally needs no logic for production of plotted results beyond two simple subroutine calls to define the calculated results data names and descriptions to the system and to make data values available for plotting.

The system allows the engineer to define up to 16 plot traces with each maneuver program execution. The plots can be full screen, half screen, 4 quadrant, or 4 stacked grids. Multiple traces are allowed on each grid with choices of plot symbol. The plot scales are arbitrary and can be changed during execution. Plot definitions may be done prior to flight or during flight and are saved on disk storage for later use. To relieve the engineer from the problem of always needing the right plot display during a flight maneuver, the system allows up to 16 separate display group combinations to be defined for use during any maneuver program. The system buffers and maintains the data directed to any of the plot groups regardless of which is currently on the viewing screen. Thus, some plot groups contain plot formats primarily for monitoring the progress of the flight, while others are formatted to assist decision-making for subsequent flights. All are under the direct control of the flight test engineer and can be displayed whenever he desires.

Operational Usage and Gains Preparation

The data system, while requiring a certain degree of familiarity, is a *priority interrupt* type system which is ideally suited to operation by a flight test engineer and requires no specialized knowledge of computer programming or computer systems. The following is a sequential description of the operations for a particular flight.

The computer is initialized to run flight test analysis from the Telemetry Engineer Station (TES). At this point the computer is configured with the proper instrumentation format and calibration information for the specific model and aircraft on which the test is to be conducted. In actual fact, since the above information, called a flight packet, resides on disk storage in the computer, the computer really configures itself in response to typed "plain English" commands. Once the station is configured, control is passed to the PES operator who establishes radio communication with the instrumentation engineer at the aircraft and initiates a calibration program in the computer. The instrumentation engineer then sends a calibration in the form of five discrete digital steps via the telemetry link. The computer, by the use of an interrupt, uses the fourth and fifth steps to compute the engineering units conversion for each transducer loaded at the TES. The pre-flight calibration is then displayed on the PES screen for review. Figure 5 shows a typical page of this calibration as displayed on the PES.

SELECTED MEASUREMENTS				10 49 42				LIMIT FAILURES		
NAME	UNITS	INITIAL	CURRENT	RBASEIC				NAME	TIME OUT	CURRENT
				MAR 21, 79						
				EVENT 860						
				FLIGHT 708-122						
				MANEUVER NUMB. 1						
FLIGHT TEST CALIBRATION SYSTEM										
OPTIONS: 1 = CHANGE 2 = DELETE 3 = UPDATE 4 = EXIT										
NAME	AD	A1	E2	RCAL	EZ STD	RCAL STD.	STATUS			
2	11150	-172571E 01	545172E 01	2044	3504	0488	0691	ACCEPTABLE		
3	11320	-202160E 02	587461E 02	2044	3504	0500	0000	ACCEPTABLE		
4	12160	-171456E 01	544255E 01	2042	3864	0977	0000	ACCEPTABLE		
5	12180	-171529E 01	543058E 01	2048	3868	0000	0000	ACCEPTABLE		
6	31000	-500312E 01	594795E 01	2060	3168	0000	0000	ACCEPTABLE		
7	31010	-880728E 01	176727E 02	2041	3424	0977	0000	ACCEPTABLE		
8	31020	-440247E 01	893141E 01	2019	3046	0846	1292	ACCEPTABLE		
9	32000	-552070E 02	105238E 03	2058	3611	1292	0946	ACCEPTABLE		
10	32010	-750831E 02	150120E 03	2048	3324	0000	0000	ACCEPTABLE		
11	32020	-619336E 02	129803E 03	2044	3185	0000	1292	ACCEPTABLE		
12	32030	-343800E 02	610563E 02	2042	3903	0977	0846	ACCEPTABLE		
13	32040	-225359E 02	145211E 02	2042	2912	0977	0000	ACCEPTABLE		
14	32050	-664416E 02	133097E 03	2044	3483	0000	0846	ACCEPTABLE		
15	35010	-659126E 01	446378E 02	138	3589	3693	2630	ACCEPTABLE		
16	35020	-340063E 01	330071E 02	472	1606	5426	5801	ACCEPTABLE		
17	35030	125730E 01	-589056E 01	480	2480	0000	0000	ACCEPTABLE		
18	35060	000000E 00	000000E 00	0	1638	0000	0000	NO RCAL		
19	36010	-210784E 02	513042E 02	1574	3517	2342	1761	ACCEPTABLE		
20	36020	-566244E 01	380213E 02	600	1525	8735	6872	ACCEPTABLE		
21	36030	937353E 00	-581673E 01	413	2403	0989	0691	ACCEPTABLE		
22	36060	000000E 00	000000E 00	0	1638	0000	0000	NO RCAL		
23	38020	138922E 00	955000E 02	0	1638	0000	0000	NO RCAL		
24	41000	-319513E 05	679717E 05	1926	2995	1381	1827	ACCEPTABLE		
25	42040	-278080E 05	635444E 05	1797	3318	0891	9000	ACCEPTABLE		
26	43000	-246502E 05	500829E 05	2016	3488	0000	0000	ACCEPTABLE		
27	43010	-249727E 05	499453E 05	2048	3504	0000	0000	ACCEPTABLE		
28	43180	-251486E 05	118492E 06	859	2275	1184	0846	ACCEPTABLE		
29	43190	-470860E 05	314013E 05	2110	3171	0977	0000	ACCEPTABLE		
30	44040	-292255E 05	116118E 06	1039	2197	1564	1827	ACCEPTABLE		
31	44050	-384462E 05	745812E 05	2111	3411	0977	1892	ACCEPTABLE		
32	44060	-216531E 05	733551E 05	1209	2200	0977	1185	ACCEPTABLE		
33	44070	-260764E 05	816253E 05	1733	2913	1092	0977	ACCEPTABLE		

10 49 35 4
EMPTY EOM TO PAGE OR OPT., LINE NUM., EZ, RCAL

Fig. 5. First Page of a Typical Pre-Flight Calibration

There are two advantages to this procedure. First, it allows the test team to ensure that all the important parameters for a flight plan are operational and within calibration tolerance. Second, it scales the computer for the actual PCM counts, thus precluding the necessity of precisely balancing each data transducer channel on the aircraft.

If all parameters are acceptable, the PES engineer selects a menu of maneuver application programs. Figure 6 is a typical menu as it would appear on the PES and contains stress analysis (SEVAL), harmonic analysis (RHARM:2), spectral analysis (RSPECT:L), and performance (H47PWR).

SELECTED MEASUREMENTS				10:48:38			LIMIT FAILURES		
NAME	UNITS	INITIAL	CURRENT	RBASIC	NAME	TIME OUT	CURRENT		
				MAR 21, '79					
				EVENT 560					
				FLIGHT 706-122					
				MANEUVER NUMB. 1					
001	RSPECT:L			SPECTRAL ANALYSIS PROGRAM - MEASUREMENT NAMES					
002	SEVALX:T			SEVAL CONT. SAMPLING, AUTO EVENT 4-78					
003	SEVALX:T			SEVAL CONT. SAMPLING, AUTO EVENT 4-78					
004	SEVALX:T			SEVAL CONT. SAMPLING, AUTO EVENT 4-78					
005	NULLMP			NO MANEUVER PROGRAM					
006	SEVALX:T			SEVAL CONT. SAMPLING, AUTO EVENT 4-78					
011	SEVALX:T			SEVAL CONT. SAMPLING, AUTO EVENT 4-78					
021	REPLOT			GENERAL DATA REPLOTTING PROGRAM, 7-77					
030	RHARM:2			TWO STREAM HARMONIC ANALYSIS, USED WITH REPLOTTING, 7-77					
031	RHARM:2			TWO STREAM HARMONIC ANALYSIS, USED WITH REPLOTTING, 7-77					
032	RHARM:2			TWO STREAM HARMONIC ANALYSIS, USED WITH REPLOTTING, 7-77					
033	REPLOT			GENERAL DATA REPLOTTING PROGRAM, 7-77					
034	REPLOT			GENERAL DATA REPLOTTING PROGRAM, 7-77					
036	REPLOT			GENERAL DATA REPLOTTING PROGRAM, 7-77					
037	REPLOT			GENERAL DATA REPLOTTING PROGRAM, 7-77					
038	REPLOT			GENERAL DATA REPLOTTING PROGRAM, 7-77					
039	REPLOT			GENERAL DATA REPLOTTING PROGRAM, 7-77					
040	REPLOT			GENERAL DATA REPLOTTING PROGRAM, 7-77					
041	REPLOT			GENERAL DATA REPLOTTING PROGRAM, 7-77					
042	REPLOT			GENERAL DATA REPLOTTING PROGRAM, 7-77					
043	REPLOT			GENERAL DATA REPLOTTING PROGRAM, 7-77					
044	RHARM:2			TWO STREAM HARMONIC ANALYSIS, USED WITH REPLOTTING, 7-77					
045	REPLOT			GENERAL DATA REPLOTTING PROGRAM, 7-77					
046	RHARM:2			TWO STREAM HARMONIC ANALYSIS, USED WITH REPLOTTING, 7-77					
047	RHARM:2			TWO STREAM HARMONIC ANALYSIS, USED WITH REPLOTTING, 7-77					
050	EQUAL:1-L			FLYING QUALITIES 4-78					
051	EQUAL:1-L			FLYING QUALITIES 4-78					
052	EQUAL:1-L			FLYING QUALITIES 4-78					
080	H47PWR:T			CH 47 PERFORMANCE PROGRAM (TABLE LOOKUP) 8-78 EKG					
081	RHARM:2			TWO STREAM HARMONIC ANALYSIS, USED WITH REPLOTTING, 7-77					
082	REPLOT			GENERAL DATA REPLOTTING PROGRAM, 7-77					
083	RHARM:2			TWO STREAM HARMONIC ANALYSIS, USED WITH REPLOTTING, 7-77					

Figure 6. Typical Selection of Application Programs

Real Time Analysis

Table II contains a listing and brief description of the application analysis programs. Referring back to the maneuver menu, Figure 6, if program 002 was selected (SEVAL), the system would initialize the stress monitor program; and, as the pilot flew the helicopter through a speed sweep, the PES plotting of (in this case) aft and forward fixed link alternating loads would be created as shown in Figure 7.

In fact, the system creates and stores up to 160 stress plots for selected aircraft strain gaged components which can be recalled for inspection from the "replot file" after the maneuver is complete.

If 046 was selected (RHARM:2), analysis of any three harmonics of 20 accelerometers would be computed and stored for recall while plots of 1, 2, or 4, accelerometers could be displayed on the PES screen as the pilot flies through the maneuver. Figure 8 shows the 3/rev component of two parameters, as they would appear on the PES.

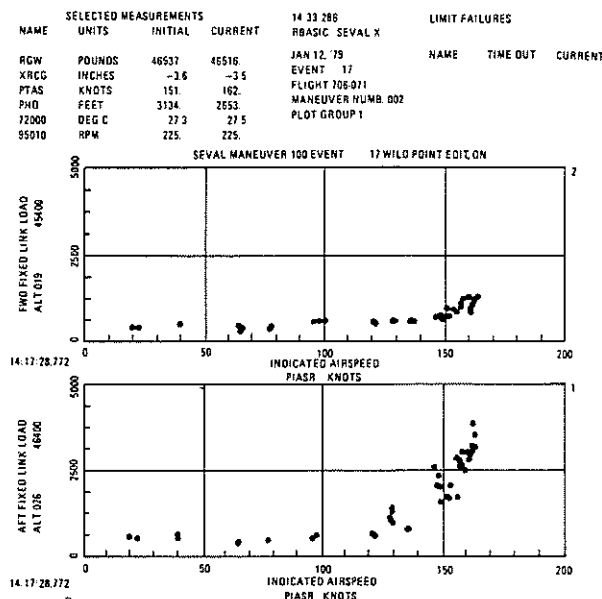

Figure 7. Typical Output From Stress Analysis Program

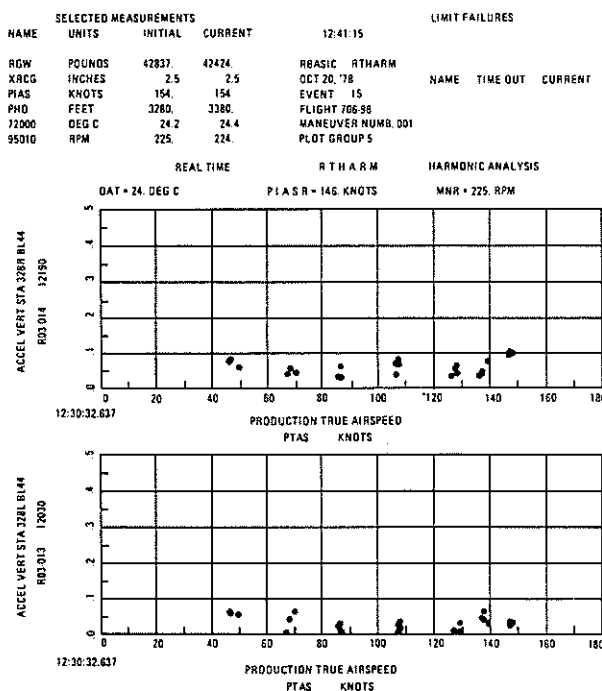

Figure 8. Typical Output From Harmonic Analysis Program

The display during a level flight performance speed increment is shown in Figure 9; while the power required curve obtained at the end of the run is shown in Figure 10.

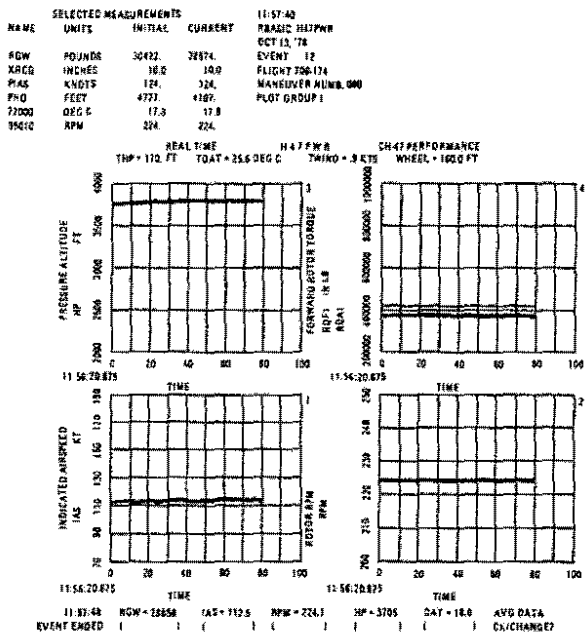

Figure 9. Performance Analysis Time Histories

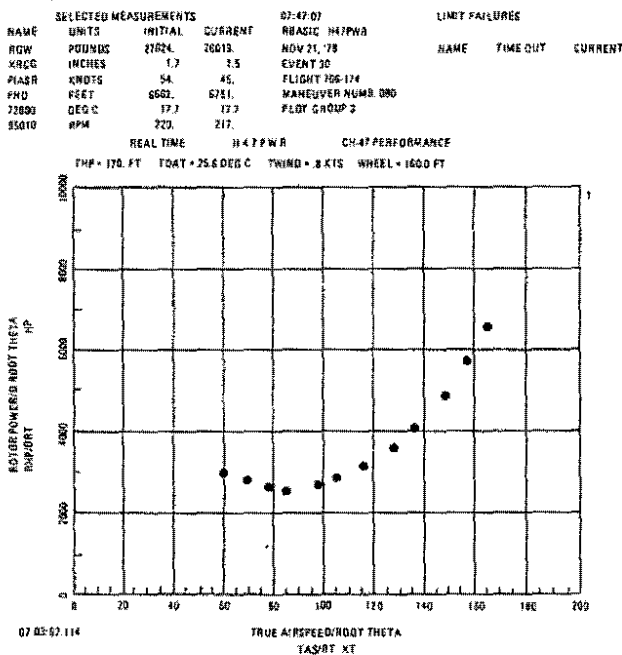

Fig. 10. Power Required Curve

For the aeromechanical or ground resonance analysis we usually employ a stick stirring technique with a target frequency generated by an electronic metronome transmitted via radio for the pilot to phase his inputs by. During the excitation, we monitor a time history of lateral and longitudinal cyclic motion. When sufficient excitation has been developed, the Test Director cuts the electronic signal, and the pilot stops the control input.

A timeslice in the period after the input is stopped is selected for spectral analysis and displayed as shown in Figure 11. The frequency of interest is scanned for the maximum amplitude. This is selected. The PES displays a damping envelope and damping values; and fails the damping time history (Figure 12) to give critical damping ratio. The ratio is listed for both the rotor and fixed system in the PES header.

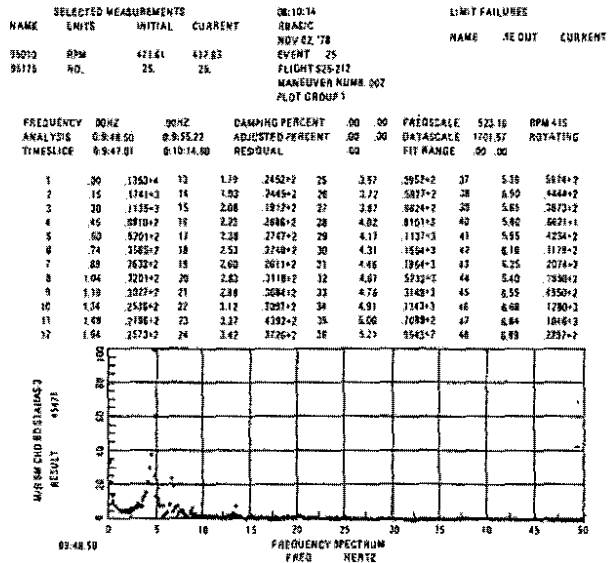

Fig. 11. Moving Block Analysis Frequency Spectrum

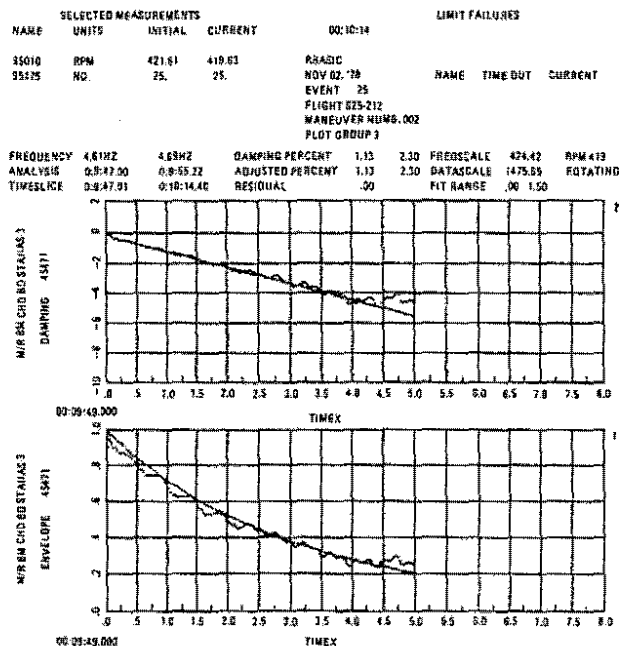

Fig. 12. Moving Block Analysis Damping and Envelope

TABLE II
REAL-TIME APPLICATION PROGRAMS

Program Name	Analysis	Description
RBASIC	Basic Aircraft Parameters	Used as a foreground application program which is designed to be used with all real-time maneuver programs. The program will generate basic aircraft flight condition parameters such as true airspeed, density altitude, rotor speed, etc.
FQUAL	Flying Qualities	FQUAL provides real-time support for static stability testing. The program calculates airspeed and altitude terms at a variable rate up to 10 times per second; permits the user to select any 24 terms (including airspeed and altitude) for time history or crossplotting; and generates a static trim tab which updates by event.
SEVAL	Stress	Provides for calculation and display of the stress analysis values steady, alternating, percent endurance limits, maxima and minima plus a selection of other calculated values. The program produces plotted output during the event and end-of-event and end-of-flight tabular summaries (Figure 9).
RHARM	Harmonic Analysis	Dynamics maneuver program which collects one revolution of data for up to 20 parameters. Computes resultants and phases of three harmonics for each parameter along with optional ratios of parameter results. The output is plots on the PES and also a data file. Figure 10 illustrates a sample resultant versus airspeed plot.
RSPEC	Spectral Analysis	Real-time program which employs fast Fourier transform to identify the frequency spectrum of any ten selected aircraft measurements. Output is PES display of normalized amplitude versus frequency.
RHARM 85%	Harmonic Analysis	Collects 20 consecutive rotor cycles of data and computes three harmonics for max, min, and 85-percent resultants. Special harmonic analysis used to correlate early CH-47A and B data with present data.
H47PWR	Performance	Provides performance calculations in terms of rotor torques, engine torques, fuel flow, and various other parameters. Displays time histories of parameters such as airspeed, altitude, rotor rpm during each event for level flight performance, and rotor rpm, cable tension, and engine torques for tethered hover performance. Speed power polars for level flight and C_T versus C_p plots, as well as tabulated data, are available at the end of the flight.
DAMP	Air and Ground Resonance	System damping analysis for ground and air resonance testing (moving block analysis). The following information is available from this program: <ul style="list-style-type: none"> (a) Time history of the excitation input. (b) Spectral analysis of any critical resonance indicator such as rotor chord bending gage or transmission or airframe acceleration (shown in Figure 11). (c) Percent damping based on the critical resonance indicators (two parameter capability) and envelope of critical frequency versus time (shown in Figure 12).
Out-of-Limits	Limit Checking	Displays six top-priority parameters which exceed present limits (upper and lower) and warns of any other parameters which are out of limit during a flight. Allows for printout of all out-of-limit parameters and values.

Replot	Allows any data stored in the data base to be plotted and hard copied. This feature allows the engineer to do flight-to-flight or aircraft-to-aircraft comparisons.
Fatigue Analysis	Recalls brush analysis data from the data base and computes life calculations based on S-N curves that can be put in at the PES.
Data Base Store	After a real-time operation or EU playback, this program gives the PES operator the opportunity to review data such as stress or harmonic analysis and store the data in the data base. If for some reason a change has to be made to the data such as the event number or maneuver code, the PES operator can do it before storing the data.

Gains

Prior to the activation and current usage of the *Star Lab* data analyzing system, a number of different engineering organizations used a variety of methods of meet computer requirements. Although in some areas this is still true, a great deal of the engineering requirements are channeled through the *Star Lab* Sigma 9. These area are

- **Simulation.** Prior to locating the STAR Sigma 9 and TES in close proximity to the flight simulator, a hybrid computer was used to interface with the simulator. With this system, considerable setup time was required; and the system was not as fast or as reliable as the all-digital computer. In a 2-hour window, which is usually made available within the flight schedule, the flying qualities group can complete analyses or moving-base simulation tasks previously requiring 8 hours. Investment cost of the computer is also approximately one-quarter of the earlier system.
- **Flight Test and Engineer Batch.** Before the use of the ATS for the UTTAS program, Flight Test used a CDC 3100 computer to convert FM magnetic tape recordings to computer-compatible tapes. These tapes, together with all engineering batch processing tasks, were processed on the BCS IBM 370 computer together with financial, business, and outside customer requirements. All flight test data processing is now handled by the *Star Lab* with no requirement to use the BCS 370 computer. Since the *Star Lab* is a dedicated cost center (i.e., engineering pays for the use of the entire system), as much engineering batch as possible is scheduled for the lab since this incurs no additional costs. Currently, approximately 45 to 50 percent of the engineering batch is handled this way.

The gains, however, have been the greatest in terms of increased value of data, enhanced data quality and together with improvements in data acquisition systems, increased productivity as measured by flight rate.

During a development or research flight test program, the final engineering answers are most valuable either during or immediately after a test. This allows for a rapid evaluation of aircraft configuration changes, quality of the test conditions and a comparison of actual versus predicted trends so that approaches to critical limits can be expedited with no loss in safety or control of the test.

The number of personnel involved in data handling to produce final engineering answers for the systems has changed over a 20 year period. Table I shows that today, with a staff of approximately one-seventh the size in 1958, we have improved the data turnaround by a factor of 15.

What is not obvious is that we are now tending to analyse for any given test two to four times the number of measurements we did 20 years ago.

The benefits in terms of flight rate are shown in Figure 13. This shows a flight rate for our CH-47C FRB program of three times the rate in 1958. It is only fair to point out that this rate was attained with a helicopter whose airframe and aircraft systems are highly reliable, having been fully developed over a number of years. But the aircraft did have a new composite rotor blade with changed aerodynamic characteristics from the previous blade. If we were to take our UTTAS and BMR experience, we would expect a flight rate of 2.5 times that rate in 1958 for a new design.

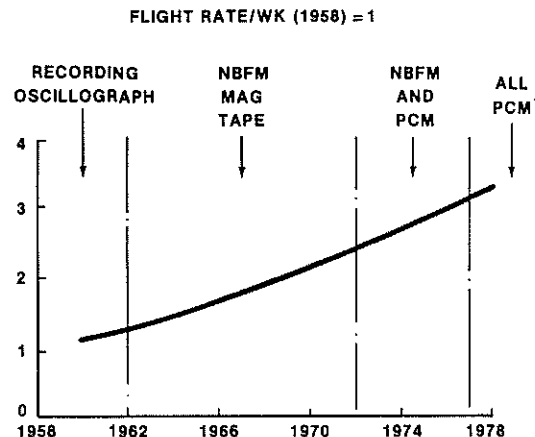

Figure 13. Flight Rate Trend For Type of Data System.

Real time acquisition also has a positive effect on overall data quality. There is generally a rapid identification and correction of instrumentation or processing errors and a resulting increase in engineering confidence in the quality of the data. In this respect, it is noteworthy that an instrumentation or calibration error becomes increasing difficult to confirm and correct with the passage of time. In this, real time processing has served to reduce the manhours spent in validation activities.

Future Development: Short Term

Although the *Star Lab* has developed programs which are used by virtually all of the technology disciplines, we do not feel that these programs will be enough to keep the engineers satisfied with future testing and helicopter requirements. Therefore, as part of an ongoing support of technology, the *Star Lab* is in

the process of developing several new programs which will be used for the commercial Chinook program.

Two of these programs will involve the use of spatial positioning equipment which we intend to use in height velocity testing and airspeed calibrations.

Previously we depended on brush charts and external camera coverage to obtain all of the pertinent data in a height velocity program. Our program will give a CRT display of this information as each point is happening, along with the capability of hard copy and computer printout.

The second program using the spatial positioning equipment will be airspeed calibration. This will eliminate the necessity of surveying ground courses, calibrated chase aircraft (which usually do not have the same airspeed capability as the test aircraft), and offsite testing at a facility which has the equipment to do an airspeed calibration such as the FAA facility we have used at Pomona, New Jersey.

Another program which is in the thinking stage is a mode shape program. This would be a very useful tool for dynamics and will have the capability of showing an entire helicopter mode shape or specific areas of particular interest. We already have a program which does a small portion of this, but because of its limitations, it has not been used as a test tool.

Long Term: Thoughts on Next Generation Data Systems

Since one of the authors of this paper is a data system user, we offer these thoughts from this point of view. An optimum real time data system should be organized to meet the following criteria:

- The CPU core should be used for system configuration, basic system operation, and control of all peripheral equipment, auxiliary processors, or special purpose analyzers.
- For multiple stream operation, applications programs should be, to the maximum extent possible, separated into equipment allocated to the data stream; i.e., simultaneous analyses should not reside on the CPU.
- The central processor should be able to load the data after each event is processed by the peripheral equipment into the data base. This frees more time after the flight for secondary analysis.
- The central processor should take and store multiple aircraft preflight calibrations to be used by any data stream.

To be specific: we think that the next generation of real time system should probably be built around a large minicomputer with the data processing handled by programmable digital signal processors (PDSP).

Each data stream should have the capability of having any number of these PDSP's linked onto the stream so that concurrent parallel analyses—i.e., stress analysis on one, harmonic analysis on another, and aircraft mode shapes on another—could be operating simultaneously.

The PDSP's as well as the PCM decommutator and any other necessary equipment should be configured and loaded from the central main processor. This central processor should have only the information that could be shared by multiple streams such as aircraft calibrations and configuration files. The central processor would also collect and store the output of each of the PDSP's into the data base any time during or after a flight.

Each real time data stream, with the possible exception of shared calibration and configuration files, would be independent of the other. Vertol operational experience with multiple data streams on a single processor, both with the ATS and the *Star Lab* has not been entirely successful. In such systems, the operation of one stream inevitably impacts the processing speed of the other, and in addition, there is a marked decrease in system reliability in a multi-stream environment. With the decreasing cost of hardware and the increasing cost of software, the additional expense of several PDSP's should be more than offset by a much simpler operating system. The reliability of a multi-stream system should be much better than that where the main CPU does all the analysis and routes the data to each stream. Couple this with the fact that due to equipment duplication with PDSP, the availability of at least one stream for real time analysis should be high.

Conclusions

The real time data (or answer) system, combined with the right kind of airborne data acquisition system, has yielded immense gains in terms of:

- Flight test productivity
 - Data quality
 - Team involvement
 - Reduced cost
- } Together these combine to help build a better product.

By using the system as a multipurpose computer, benefits can also be attained in other areas in addition to Flight Test; i.e., Simulation, Engineering Batch, and Terminal Job Entry.

While we have previously discussed productivity, data quality, and cost, we have not addressed the team involvement aspect. This is difficult to quantify, yet it is obvious that if the pilots, flight test engineers, technical discipline specialists, computing support personnel, and, at times, the customer are constantly aware of the final answers from a given test, morale and enthusiasm are much higher than if many of these personnel never see the test results.

In this respect, since the early planning for real time analysis at Boeing Vertol, we have located together to the maximum extent possible the engineers, computer programmers, and computer technologists involved in flight testing. We have not always, due to the test site at which the aircraft was located, integrated the pilots, although this has now been attained. Without the constant dialogue associated with living together and a developed mutual confidence in each other it is likely that we would not have been so successful. One aspect that was touched on briefly earlier in the paper is that the system forces an increase in the capabilities of all the team members involved, whether they are test engineers, technologists, programmers, instrumentation engineers, or data processing personnel. The system also forces more careful, thoughtful, and earlier planning if the hardware and software are to come together to produce the intended results.

While we have attained our objective in terms of increased productivity and quality of answers on-line, we have learned (or are just beginning to learn) something about the limitations of operating sophisticated programs simultaneously. The steps required in terms of increase in core size or the use of special purpose analyzers are discussed in another section of this paper.

Finally, as in most endeavors, fortune played a large part in developing the final system in that we *had* to face the challenge of the UTTAS program, together with:

- Airborne PCM
- Support from company management
- A dedicated and highly competent test team
- The Grumman experience

and, in the end result, the economic constraints which gave us a large-scale central processor and limited peripherals.

Acknowledgements

While not specifically noted in this paper, Boeing Vertol's involvement in developing the current data system has been documented, together with more specific program usage and methods employed to validate results in the following technical papers and presentations:

- | | | |
|----|-----------------------------------------------------------------|-------------------------------------------------------------------------------------------------------------------------------------------|
| 1. | D. Marshall &
H. Steinmann
(BV Co.) | UTTAS Flight Test,
Real Time Data
Analysis Amer Helo
Soc, (1974)
Pre-print No. 864 |
| 2. | K. Lunn, et al
(BV Co.) | UTTAS Flight Test-
ing, The Calverton
Experience. Soc.
of Flight Test
Engineers, Long
Island, N. Y.
Feb 1976 |
| 3. | K. Lunn
C. Hutchinson
(BV Co.)
J. Obbard
(Raytheon) | Realization of a
Helicopter Real Time
Data System. Amer
Helo Soc (1979)
Pre-print 79-50 |
| 4. | C. Hutchinson
H. Steinmann
(BV Co.) | Flight Test Data
Acquisition & Inter-
pretation. AHS Fatigue
Methodology Specialists
Conference, St. Louis, Mo.
(1980) 8-1 |
| 5. | B. Blake
K. Lunn
(BV Co.) | Helicopter Stability and
Control Test Methodology.
AIAA Atmospheric Flight
Mechanics Conference
Danvers, Mass. (1980) |

In preparing this paper the text was typeset and produced by Mr. Jim Knopp on his home printing machine. The illustrations were produced with the assistance of Mr. C. Hutchinson of the Flight Test Engineering Staff and Mr. R. Martin (an MIT student intern in BV Flight Test). We wish to express our thanks to the above in producing a low budget paper.