

Evaluation of an Advanced Display & Control Concept for Helicopter Adverse Weather Flight

Volker Gollnick, Head of Dept. "Cockpit Systems & Simulation"

Email: volker.gollnick@eurocopter.com

Ralph-A. Schmidt, MMI Engineer

Klaus Heidenreich, System Engineer

Eurocopter Deutschland GmbH

Munich, Germany

Abstract

A mission phase related display and control concept for helicopter flight in adverse weather is presented providing all the capabilities to plan and perform a rescue mission to an unknown accident place and to land in a confined area. Baseline for the definition of the display and control concept is a specific rescue mission trajectory ensuring a high level of safety and obstacle avoidance. For this purpose a system concept was developed allowing helicopter flight in controlled airspace and precise navigation. The system also comprises components for obstacle avoidance and data link.

The control and display concept described here is related to the specific mission phases. The described flight tests show a good acceptance of the concept and the practical relevance of the control and display concept.

Abbreviations

ADI	Automatic Direction Indicator
AFMS	Advanced Flight Management System
ATC	Air Traffic Control
AWRH	All Weather Rescue Helicopter
BGS	Bundesgrenzschutz (German Border Guard)
CDI	Course Deviation Indicator
CDU	Control & Display Unit
EMS	Emergency Medical Service
FFK	Fixed Function Key
FMS	Flight Management System
D/GPS	Differential Global Positioning System
HEMS	Helicopter Medical Service
HMIC	Human Machine Interface Computer
HOCAS	Hands On Collective And Stick
HUD	Head Up Display
IFR	Instrument flight rules
JAA	Joint Aviation Authority

JAR	Joint Aviation Regulation
LDC	Look Down Camera
LFC	Look Forward Camera
LSK	Line Select Key
MMI	Man Machine Interface
MRVA	Minimum Radar Vectoring Altitude
ND	Navigation Display
NOE	Nap Of the Earth
OASYS	Obstacle Avoidance System
OCL	Obstacle Clearance Level
OPS	Operational Standard
OWS	Obstacle Warning System
PFD	Primary Flight Display
VFR	Visual Flight Rules

Introduction

Flying a helicopter in adverse weather requires precise navigation and a very good situation awareness of the pilot although outside view is limited. Within the German National Aerospace Research Program in 1995 the project „All-weather Rescue Helicopter“ (AWRH) was launched to investigate a cockpit and system concept which may allow performing rescue flights in bad weather conditions like fog and rain, [1]. The major risk of such flights is related to obstacles like trees or power lines which the pilot does not realize early to avoid.

The latest issue of JAA-HEMS-OPS reduces the flight envelope of a rescue helicopter to roughly a half by requesting a minimum horizontal visibility of 1500 m at day instead of 800 m before. In order to recover the former performance and reliability of airborne rescue services it is obvious, that a mission system has to be developed to fly helicopter in adverse weather.

For this purpose a Display and Control Concept was developed providing to the pilot comprehensive information about the obstacle situation around the flight trajectory and also precise information about the flight state and position.

Similar activities were performed in the early nineties within the American OASYS Program. This program was focussing at military helicopter NOE flight, [4]. The major issue of this program was to develop an

obstacle avoidance system containing active sensors and the development of appropriate MMI.

Also in Japan comprehensive investigations are under way to improve flight safety during adverse weather flights, [5]. The major goals of this program are to improve the ability of helicopter instrument flights, which are assumed as typical for adverse weather flights, and to improve flying qualities, [6].

The Mission

The Emergency Medical Services (EMS) mission defined for a civil helicopter flight in adverse weather is based on the existing air space structure and a proposal for a modified air traffic control procedure. The most critical phase during the mission, which is actually not covered by the European Aeronautical Law, is the descent below MRVA where no radar and communication contact to ATC is guaranteed. Therefore the mission will have to be performed in uncontrolled airspace, where normally only VFR flights are permitted and controlled airspace where IFR flights are possible.

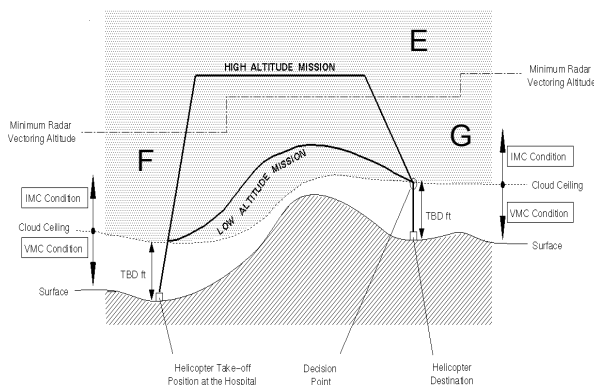

Figure 1: AWRH Mission Profile

Emergency Medical Service (EMS) operations in adverse weather is understood to allow flying close to CAT I conditions with a decision height of 200ft and horizontal visibility of 800m (2500ft). These requirements would bring back the mission envelope given before JAR OPS 3 was issued. Considering this, it becomes obvious that there is a strong need for adverse weather flight mission systems. The definition of this mission profile is driven by the requirement to ensure flight safety at a maximum. Flight above MRVA and the guidance of ATC will protect the helicopter from collisions during departure and enroute.

For the departure from the operation base, e.g. a hospital, a special uncontrolled IFR sector is activated, which forces unknown VFR Traffic to take into consideration higher weather minima or to fly around this airspace. Reaching the controlled airspace the flight will be performed under control of ATC to the

buffer zone, where the helicopter will leave the controlled airspace and where he will return after picking up the patients. During these phases flight safety is granted by ATC and the selected altitude.

At the Minimum Radar Vectoring Altitude (MRVA) the helicopter leaves the controlled area and flies the descent to the first decision height in the uncontrolled airspace. At this point the proceeding mission is actually not covered by Aeronautical Law. If at this point the obstacle detection sensor provides a sight to the ground, the approach to the second decision altitude can be continued, relying on an active RADAR sensor to detect and display obstacles along the flight path. At the second decision height outside view must allow visual contact to the landing site and a landing in VMC. After the departure from the accident site the helicopter will climb back to the buffer zone, which ATC kept clear of traffic for the time required to land at and depart from the accident site. Reaching the MRVA, ATC will pick up the helicopter provide control service for the flight back to the base.

System architecture

The helicopter mission defined before requires a dedicated sensor concept and system architecture, [2].



Figure 2: AWRH Test Bed EC FUTURA

Precision navigation and positioning is realized using an AHRS-supported GPS-System.

Data communication with the ground station is actually based on a ModaCom. A laser based Obstacle Warning System (OWS) is applied for obstacle detection instead of an envisaged radar system.

These main sensors are complemented by an Human Machine Interface Computer (HMIC) and an Advanced Flight Management System (AFMS), comprising an advanced Control and Display Unit (CDU) and an advanced Navigation Display (ND).

The different components are linked using standard ARINC 429 and a CAN Bus [7], which forms part of the mission system.

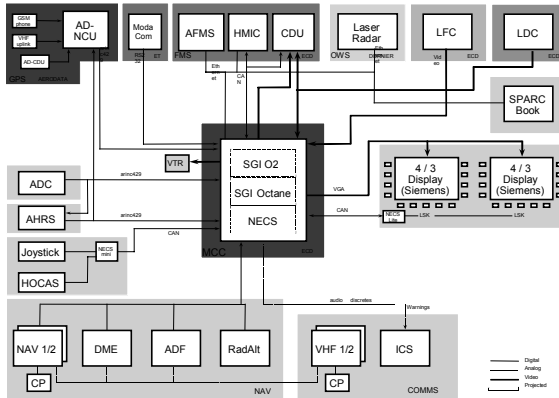

Figure 3: AWRH System architecture

The Display & Control Concept

The display and control concept developed for the AWRH is defined according to the mission and its different phases. It comprises

- An Advanced Flight Management System and a CDU
- A Navigation Display for mission planning and monitoring
- A Primary Flight Display for flight navigation guidance.

According to the individual mission phases all necessary control and display features are provided to the crew, [3].



Figure 4: Display Arrangement in the Cockpit

Two displays are installed in the cockpit panel to provide the navigation display and PFD presentation to the crew. Typically the navigation display will be allocated to the center display while the PFD is presented on the right display. This allows both crew members to monitor the flight simultaneously. The CDU/FMS is located in the center console right below

the center display. So the crew can immediately monitor the inserted waypoints on the ND.

FMS and CDU

A Control and Display Unit (CDU) is provided to the crew to create and manipulate flight routes. The CDU will be preferred for precise flight planning of IFR flight. The CDU is not only the IO-Interface for data insertion and manipulation, but it contains also the FMS computer.



Figure 5: Control and Display Unit

The Flight Management System as part of the CDU is designed for 4-dimensional flight planning and navigation. Also, it was tailored to the needs of helicopter operations and features the following highlights.

- A powerful flight planning module which creates a 4-dimensional trajectory with respect to various terrain, ATC, meteorological conditions, helicopter and pilot constraints.
- An helicopter performance calculation module, which processes many flight and safety relevant data, like ceilings, rate of climbs, hover altitudes, ranges, endurances, optimal speeds, all for all engine operative and one engine out conditions.
- A weight and balance calculation module, which processes weight and fuel figures for the pilot and issues warnings when limits are exceeded.
- A Special Approach Generator, which creates a safe approach path to unknown landing sites, considering the helicopter performance, terrain, weather and human properties.

- A bi-directional interface to the ND, which allows for the acceptance and processing of ND generated constraints and commands.
- An advanced HMI, which is oriented on the tasks a pilot has to perform during the mission, i.e. Preparation of the flight, Monitoring the progress, Communicate with ATC and keep informed about (and manage) the aircraft.

With these features the CDU & FMS represents the device, the pilot needs to plan all relevant parameters for the flight and to react on unforeseen situations. This allows safe operation, regardless of the support of an flight operations center.

When the flight route planning is completed the Navigation Display is used for monitoring the real flight route. In the monitoring mode also a horizontal and vertical view to the actual flight path is provided to the crew.

Navigation Display

Within the Control & Display Concept a Navigation Display was designed allowing the crew to easily create and modify the flight route during a mission and to monitor the progress along the planned route. The Navigation Display is intended to be used especially for VMC flight planning and for modifying and monitoring the flight route during flight.

For this purpose the navigation display provides a preparation and a monitoring mode.

The preparation mode allows the pilot to plan his flight route. The pilot can select a horizontal presentation of a 2D-map display or a vertical view to the trajectory are provided on two different displays. The two display design was chosen to provide as much detailed information about the trajectory as possible. On the other hand pilot workload should have been reduced by using one screen display for one presentation.

For the definition of a flight plan he can select or create the desired waypoints using a joystick, which is mounted in the center console.

This enables rapid planning, when highest accuracy is not required, but time is very limited. On the other hand, if the precise coordinates of the route way points are known, the pilot can use the CDU in the center console to create the flight plan.



Figure 6: Preparation Mode – Horizontal

Extensive flight planning or flight plan modifications are usually required before take-off.

During each flight, the NAV-prepare page also allows to modify easily flight routings. These actions are executed using the joystick by clicking on the waypoint to be modified and thereafter selecting the requested function from the object dependent menu. Waypoint characteristics and functions, like „delete WP“, „VFR departure“, „IFR departure“, „fly by“, „fly over“, „hold at“ are elements of the object dependent menus just as the selection of a departure or arrival route.

The NAV-prepare page is overlaid with aeronautical information. Together with the road map, this form of representation shall perfectly support the crew during search and rescue missions.

Altitude constraints for waypoints can be defined on the vertical view of the NAV-prepare page. A LSK allows to toggle between horizontal and vertical view. Comparatively to the horizontal view, the joystick allows to set the desired altitude constraints.



Figure 7: Preparation Mode – Vertical

During the preparation mode the vertical flight path trajectory will be created according to the actual

obstacle information derived from data link information or map data base.

NAV Monitor Format

A important task for the flight crew is to monitor the ongoing flight progress. Deviations between the planned and the actual flight route in latitude and altitude must be recognized immediately.

The NAV-monitor page offers this monitoring function in a horizontal and vertical view.

The appearance of the NAV-monitor page is similar to the layout of the NAV-prepare page.



Figure 8: Monitoring Horizontal mode

The actual flight route and the helicopter position are overlaid in correlation. The MMI design for the monitoring mode shows a heading up representation of the flight path. The flight path as well as the map move under the aircraft symbol, which is located at the lower part of the ND. Additional information like „heading“ or „distance to the next waypoint“ are indicated at specific locations at the NAV-monitor format.

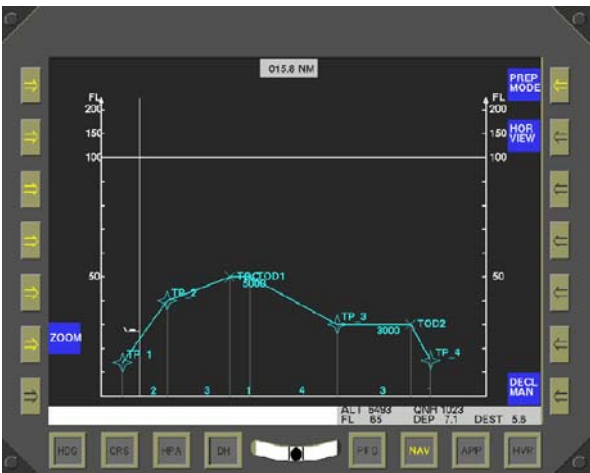

Figure 9: Monitoring Vertical Mode

In the vertical mode, which is considered the important for obstacle avoidance, the helicopter reference line is

left aligned on the screen. A helicopter moves up and down the reference line when the helicopter changes its altitude. The vertical representation of the trajectory moves from right to the left. The up/down movement paired with the right to left movement of the trajectory presents to the pilot a clear and easy perceivable information about the helicopter position with regard to the required vertical profile and allows a quick check of the current vertical state.

The Primary Flight Display

The Primary Flight Display (PFD) provides the basic flight state information, like indicated airspeed, barometric height, torque, heading and variometer. In addition it is designed to provide additional guidance aid for helicopter flight in degraded vision. For this purpose different underlays can be allocated for the related mission phases, i.e.

- 3D-Map
- Obstacle Web
- Tunnel in the sky

It is the basic idea of this concept to use an imaging obstacle sensor like the radar based Heliradar for obstacle detection and enhanced vision. Although such a sensor was announced but is not available today, the PFD display concept allows to change the guidance aids without modifying the display concept itself. Classical flight state instrument representation is used to provide a well known environment for the basic flight state indication in order not to exceed pilot workload. Another advantage of this kind of symbology is given by providing qualitative information about the actual value of a parameter or tendencies about its behavior.



Figure 10: Primary Flight Display Layout

Additional specific information is provided for helicopter flight in limited vision.

The flight director command cues - part of the ADI - displays computed commands to capture and maintain a desired flight path.

The decision height display indicates the selected decision height.

The waypoint information display indicates the name, the bearing, the EET and the distance to the selected waypoint. The desired waypoint, e.g. IFR fix, VFR fix or GPS coordinate, is selected on the CDU.

The radar height and the DH flag are part of the ADI. The radar height appears when passing 2500 ft AGL at the lower part of the ADI.

Selection of the sector mode replaces the full HSI compass rose with an 90° arc format in order to provide a wider view to the underlaid display.

Further indications like ADI, speed indications, altitude information, vertical speed, power setting, waypoint information, NAV source selection, wind and status information remain unchanged.

APP Format

The Approach „APP“ format allows to choose different underlays in addition to the classical PFD. This page should be selected shortly before starting the descent to the obstacle clearance limit which is indicated by the obstacle web and during the final approach into unknown and unclassified landing-sites. This page enables the pilot to navigate and control the helicopter in accordance to the flight guidance symbology and to fly the helicopter „quasi-visually“ in accordance to a sensor image or 3D map underlay.

The sensor image will be - depending on the sensor system - a full screen HeliRadar image or a Laser Sensor image.

An active sensor is mandatory to recognize and identify obstacles on the final approach track, which are not covered by the map data base.

The symbology of the screen center, especially the symbology of the ADI, can be removed for a better sensor view into the landing-site. Symbology of the aircraft symbol and the radar height remain steady. Further information of indicated airspeed, barometric altitude, vertical speed and torque are indicated at the same screen position compared to the PFD page. Keeping the screen center clear of symbology is the reason for indicating the heading information and all bearing pointers at the lower screen edge as a linear tape.

Further flight guidance and obstacle warning symbology can be selected as an overlay. Toggling a LSK allows to switch on and off a „tunnel in the sky“. The tunnel can be used for a safe guidance during arrival and departure at the landing-site. Approaching the obstacle clearance limit can be observed by using an obstacle-web. The appearance of the obstacle-web can also be selected by pushing a LSK.

In addition this information is underlaid by several displays.

APP-Web Format

Several studies for obstacle warning symbology have been performed in the last years:

- color coded obstacle range,
- contrast color coded obstacle,
- obstacle web symbology.

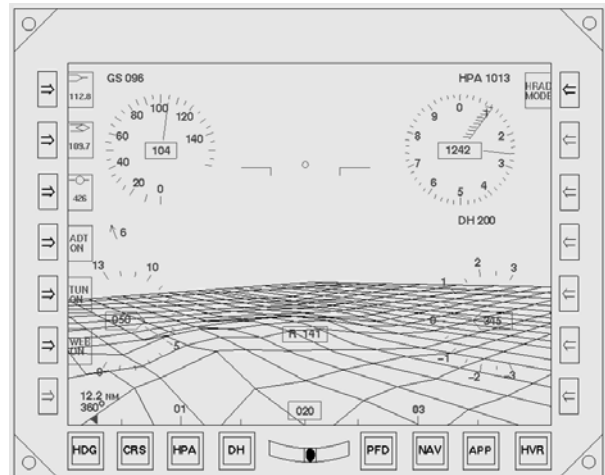

Figure 11: Obstacle Web Underlay

The obstacle web was selected as the most appropriate obstacle symbology in terms of global warning situation (instead of local obstacle warnings) and of an intuitive interpretation of the flight situation.

The web is calculated in a safety height above all obstacles detected by a high resolution radar sensor. The safety height can be selected and changed by the pilot in accordance to the DH input. A rectangular web geometry was selected for a better orientation during maneuver flight. The color of the web is depending on the obstacle height in relation to the helicopter height. Web coordinates, above the helicopter height are colored in red. Other web coordinates are colored in green. A final color design of the APP page will optimize the contrast ratio between the web symbology, the flight guidance symbology and the sensor image underlay.

This display symbology has been only developed and evaluated in the ECD Experimental Cockpit Simulator (DeCo).



Figure 12: ECD Experimental Simulator DeCo

The obstacle web will be colored red to indicate the dangerous flight level. During the simulation evaluation it was found, that this kind of symbology provides good situation awareness to the pilot.

Because the Heliradar is not yet available, it was decided to introduce a laser-radar based obstacle avoidance system, which is not an imaging sensor and its use is limited in bad weather conditions for physical reasons. This sensor provides a rough pixel image of detected items indicating their position and distance which is shown in a color code. This image was not implemented in the display concept.

However the designed display and control concept incorporates the flexibility to introduce or to replace different underlays of sensor images of guidance aids without changing the whole concept.

APP-3D-Map Format

A 3D-navigation based on a digital map data base is provided alternatively to the sensor display. This underlay is used for a three-dimensional navigation, outside of the obstacle clearance limit. The viewing direction and the three-dimensional calculation algorithm of the 3D-map ensures correlation between the map orientation and the sensor line of sight.

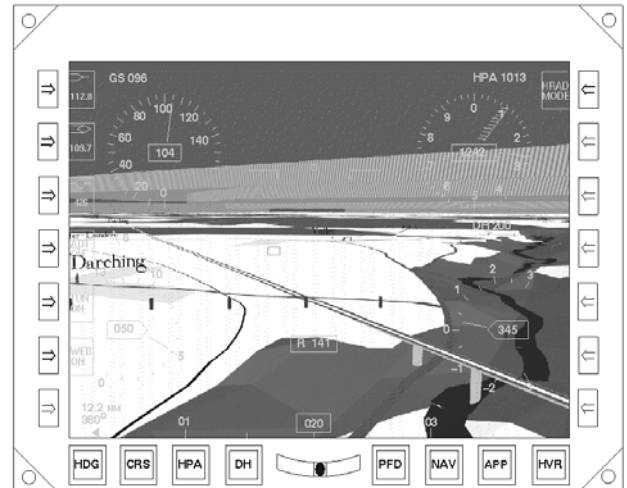

Figure 13: 3D Digital Map Guidance Display

It can be used by the pilot above the obstacle clearance limit for navigation and orientation. The usage of the 3D-map shall merge several advantages:

- Indication of the three-dimensional surface structure of the environment to maintain safety margins to the ground level.
- Appearance of the three-dimensional airspace structure for circumnavigation of restricted airspace in latitude and altitude.
- Appearance of a three-dimensional routing for lateral and altitude guidance.
- Clearly arranged and reduced landmark and topography symbology for improved orientation.

The 3D-map shall be calculated out of a database. However, it is a fact, that most of the used data of the database (like landmarks or topography) reflect a state of the past. New power lines or TV-towers, built up during the last months, are not considered in the database on board of the helicopter. This is the most reason for using the 3D-map above the obstacle clearance limit only.

APP-Tunnel Format

A „tunnel in the sky“ is used by the pilot as a guidance aid during departure and approach. At departure, the tunnel will guide the helicopter to an save altitude above the obstacle clearance limit and vice versa during approach. The tunnel is aligned to the real world environment. The tunnel is calculated by the Advanced Flight Management System (AFMS), taking into account ground surface and obstacles considered in the data base, helicopter performance, forecast and calculated wind speed and direction. Based on this information the AFMS will calculate an appropriate approach tunnel.

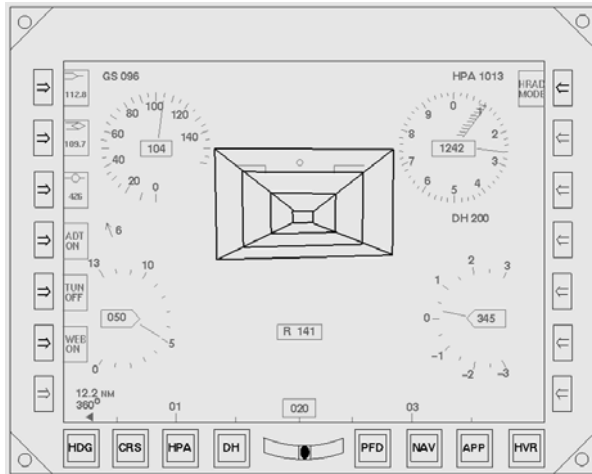

Figure 14: Tunnel Guidance Aid

While the actual helicopter position is measured precisely by DGPS the piloting task is to keep the helicopter symbol within the tunnel.

Mission Phase Related Page Allocation

The page allocation to the left and right display is depending on the pilot's needs and conventions. Both displays are equipped by the same functionality. The page selection is performed manually by the crew. Each page can be selected on each display.

Recommendations of page allocations at various flights are listed in the following paragraphs:

VFR FLIGHT

- a) Conventional VFR Navigation:
NAV page on the left display and PFD page (rose or sector) on the right display will be recommended for conventional VFR flights.
- b) Fly Around of Restricted Airspace:
NAV page on the left display and APP-3D-map page on the right display will be recommended for the circumnavigation of restricted airspace.

IFR FLIGHT

NAV page on the left display and PFD page (rose or sector) on the right display will be recommended for conventional IFR flights.

- a) Departure
NAV page on the left display and APP-sensor page (including tunnel and/or web overlay) on the right display will be recommended for the departure phase of .
- b) Enroute (Low Level)
NAV page on the left display and APP-sensor page (including web overlay) on the right display will be recommended for low AWRH enroute flights.

- c) Enroute (High Level)
NAV page on the left display and PFD page (rose or sector) on the right display will be recommended for high enroute flights.

- d) Approach (above Obstacle Clearance Level, OCL)
NAV page on the left display and APP-sensor page (including web and tunnel overlay) on the right display will be recommended for the approach above the obstacle clearance limit.

- e) Final Approach (below OCL):
Deselection of all overlays will be recommended to get a good view of the sensor image. Flying below the OCL is usually a flight below the obstacle web - a reason to deselect the web. The landing-site must be visible on final approach (OCL corresponds to the DH) - a reason to deselect the tunnel guidance. NAV page or the image of the „look down camera“ (LDC) on the left display and APP-sensor page (no overlay) on the right display will be recommended for the final approach below the obstacle clearance limit.

- f) Missed approach procedure:
NAV page on the left display and APP-sensor page (including web and tunnel overlay) will be recommended for the missed approach procedure up to an safe enroute altitude.

Cruising in Adverse Weather

During cruise level flight a 3D-map display is offered to the pilot with an overlay of the basic flight state information.

The 3D-Map gives an orientation to the pilot when outside view is limited. In the data base not only topographic data are provided but also air space structures are indicated. Such a presentation gives information about restricted areas e.g. if there are military air zones.

Approaching to unknown Area

According to the defined mission profile the helicopter will leave the controlled airspace. During this phase the pilot will switch to an obstacle web display used as an underlay.

Final Approach

The final approach will start at the second decision point at 200ft. The final approach will be performed when the pilot can see the ground. The final approach will be performed in VMC.

Flight Test Results

In January 2001 a flight test campaign was started to investigate the acceptance of the system in flight and to evaluate the benefits of the display concept regarding pilot workload reduction. The flight tests were performed with 2 pilots. Each pilot was more experienced in VFR or IFR flight giving a different evaluation background.

Before starting the flight tests the pilots were trained on the new control and display concept and the envisaged flight test using the ECD experimental simulator. This approach was found to be very efficient and gave a good impression about the real flight task.

During the first flights the 3D-Map display was evaluated as flight guidance aid during cruise. The flight task was defined by several landmarks the pilots have to follow while flying to a certain landing point. Highway crosses or locations were used as way points, rivers or road indicate flight paths. Having performed this task the pilots remarked a high level of compliance between the map display and the outside view. Therefore the pilots felt very confident in the 3D-Map display. This was found to be an interesting and important result, because normally the reliability and consistence of data bases is a big issue.



Figure 15: 3D-Map used in flight

The principle concept to provide underlaid guidance information together with primary flight state information is well accepted. It was recommended to improve the contrast ratio between the flight instruments and the map landscape representation should have been extended. After improving this the 3D map seems to be a very interesting guidance aid for cruise flight above obstacle clearance in limited vision to give the pilot a better orientation and situation awareness when outside view is limited. Considering that also in fog or rain there is some outside view, a 3D map supports the pilot's imagination of what is coming next. Also obstacles covered by the data base will be indicated earlier. However without any active sensor

which provides a good range of sight also in bad weather conditions it is not possible to fly a helicopter within a confined obstacle area.

A second flight tests will be performed, shading the test pilot's wind shield. The objective of this test will be to evaluate the pilot workload and required capacity using the 3D map as a guidance aid in cruise.

Some additional flight test were performed investigating the tunnel-in-the-sky-concept as a guidance aid used together with the 3D map display. While the actual helicopter position is measured using D/GPS the piloting task is to keep the cross pointer within the tunnel.

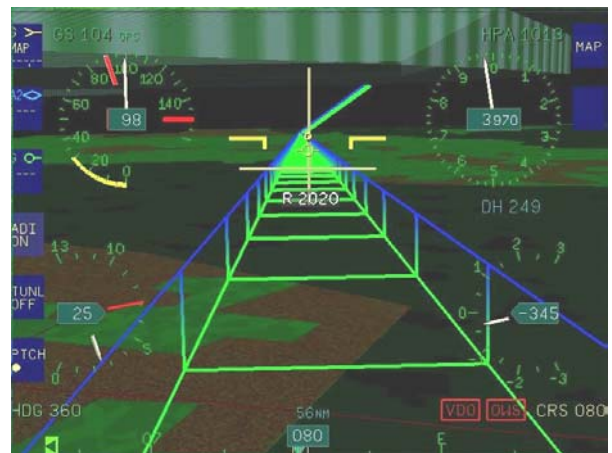

Figure 16: Tunnel Guidance Aid used in Flight

The first trials had shown, that the tunnel width was found to be too small. After enlarging the tunnel width up to 35 m the pilots accepted the tunnel as a guiding aid. Different glide slopes between 3° and 10° were investigated.

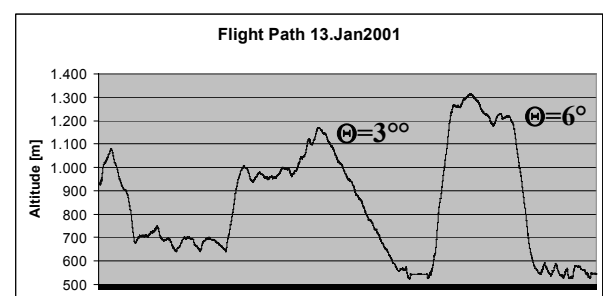

Figure 17: Piloted flight path using the tunnel

The figure shows, that the tunnel as a guidance aid allowed to precisely acquire the required flight path. During the approach the flight path occurred as a straight line. This result underlines, that the tunnel as a guidance aid is very well suited for precise approaches into confined areas. Using the tunnel guidance aid within the 3D-map is appreciated by the pilots improving situation awareness.

The next flight tests will focus at the evaluation of the workload and the influence of the this guidance aid on handling qualities. For this purpose a flight test matrix was defined to get a valid data base.

Air speed	40 kts	50 kts	60 kts	70 kts
Glide slope				
3°				
6°				
8°				

Table 1: Flight Test Matrix

The flight matrix shown above will be performed with the tunnels guidance aids. As a reference classical IFR ILS approach will be flown with 3° and 70 kts. For all trials a detailed handling qualities assessment will be conducted using a detailed questionnaire and the Cooper-Harper-Rating scale at the end.

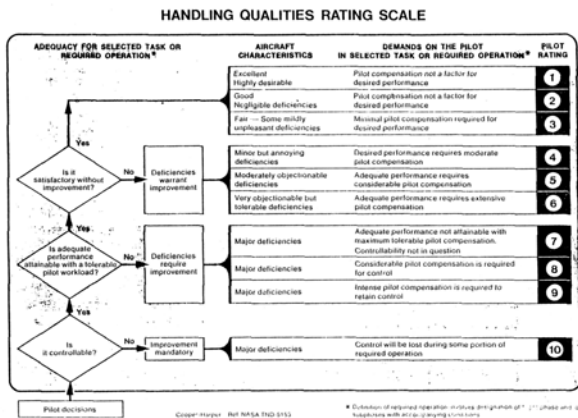

Figure 18: Cooper-Harper-Rating Scale,[9]

The goal is to get detailed and valid information about the impact of the display and control concept on pilot workload and handling qualities.

Outlook

After completion of the trials during phase II of the project a holographic Head Up Display will be developed. The holographic screen will be fixed in the line of sight of the pilot on the front window. The limited field of display of about +/-10° was found as a major constraint for the development of an optimized symbology for obstacle flight direction indication. Another major issue for phase II is the investigation of an appropriate obstacle presentation to the pilot. Because actually no imaging sensor is available and also no sensor is able to detect obstacle under all weather conditions new concepts have to be investigated to provide to the crew valid and confident information about the actual obstacle situation around the flight path. For this purpose digital data bases and OWS data will be fused to provide to the pilot an actual obstacle indication on the map.

Detecting unknown obstacles for sure is the major system requirement influencing the control and display concept. Due to physical reasons it is not possible to detect obstacles with only one sensor. Therefore a sensor data fusion is necessary having a direct impact on the control and display philosophy.

At first a minimum outside view must be given during the final approach.

For the next time no imaging sensor will be available, so that active obstacle detection has to be fused with digital data base information.

Summary

A mission phase related control and display concept was developed for helicopter flight in adverse weather. Flight planning is performed using a navigation display where routes can be edited. The Navigation display provides a preparation mode and a monitoring mode for defining and observing the flight route.

The primary flight display was designed using rose formatted symbology, which is appreciated during flight in limited view because it provides good qualitative information about the flight state.

Three different underlay displays are defined for cruise and approach phase.

The obstacle web display based on digital map data indicates the airspace below to be confined. The tunnel format display provides a very well accepted guidance aid for the final approach.

The 3D map display provides appropriate information about the flight route to the pilots.

For the next phase a new HUD symbology is under development for indicating obstacle areas and the flight state.

During phase II of the All Weather Rescue Helicopter Project the control and display concept will be adopted to the OWS available. The flight path planning will be expanded to calculate a flight path taking into account constraints. Also a sensor data fusion between digital map data and OWS data will be performed considering also the precise flight path measured by D/GPS.

References

- [1] S.Haisch et al.: AWRH, Contract Report Phase 1, Munich, 1999
- [2] S.Haisch, K. Heidenreich, V.Gollnick: „The All Weather Rescue Helicopter – Flight Guidance Concepts for an extended Mission“, (in German) Presentation at the DGLR Annual Forum, Leipzig, 2000
- [3] V. Gollnick, R.-A. Schmidt, K. Heidenreich: „A Display and Control Concept for Helicopter Flight in Adverse Weather Conditions“, 57th Annual Forum of the American Helicopter Society, Washington DC, May 9-11, 2001
- [4] F. Corlucci: “Safety in the OASYS“, Defense Helicopter, March/April 1992

- [5] K. Kobayashi, Y. Kumamoto, et al.: „Development and Evaluation of Precision Approach Profile in IMC for Civil Rotorcraft“, 56th Annual Forum of the American Helicopter Society, Virginia Beach, Virginia, May 2-4, 2000
- [6] K. Amano, K. Kimura, et al.: „A Study to Improve Flying Qualities in IMC for Civil Helicopters“, 56th Annual Forum of the American Helicopter Society, Virginia Beach, Virginia, May 2-4, 2000
- [7] M.Stock: „The AWRH avionics interface system, Technical Note, Stock Micro Computer Systems, Berg-Farchach, Germany, 1999
- [8] R.A. Schmidt: “Operational Concept for the All Weather Rescue Helicopter“, TN-D/EE73-29/96, Eurocopter Deutschland GmbH 1998
- [9] G.E. Cooper, R.P. Harper: „The Use of Pilot Rating in the Evaluation of Aircraft Handling Qualities“, AGARD Report 567, April 1969