

NINETEENTH EUROPEAN ROTORCRAFT FORUM

Paper No. D1

CONFIGURATION AND PROGRAM STATUS OF  
EUROCOPTER'S NEW LIGHT TWIN HELICOPTER EC 135

by

*Claudius Zwicker*

Eurocopter Deutschland

September 14-16, 1993

CERNOBBIO (Como) Italy

ASSOCIAZIONE INDUSTRIE AEROSPAZIALI

ASSOCIAZIONE ITALIANA DI AERONAUTICA ED ASTRONAUTICA



# "Configuration and Program Status of Eurocopter's New Light Twin Helicopter EC135"

by  
Claudius ZWICKER  
Eurocopter Deutschland

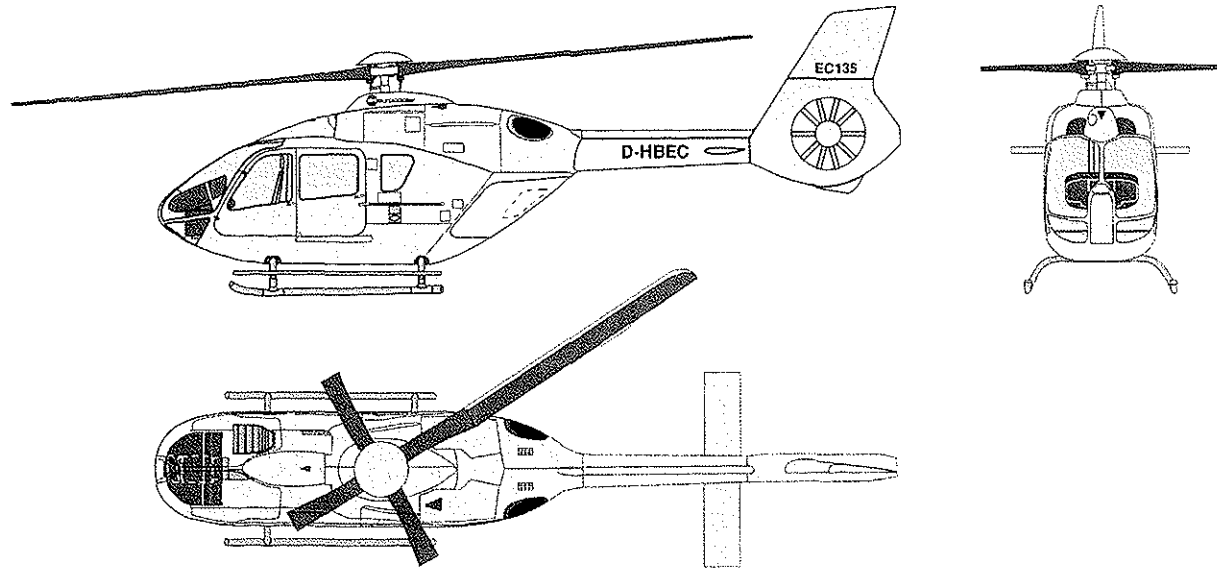

## ABSTRACT

In October 1988 the first flight of the BO108 VT01 took place. This helicopter has been used as a flying test bed to verify the characteristics and performances of the main systems. More than 250 h has been flown with the VT01. Several presentations have been given with regard to development of main systems [1], used technologies [2] or test results [3].

In June 1991 the second prototype VT02 joined the test program. This h/c was for the first time equipped with a FADEC controlled engine (TM 319-1B). Beside fine tuning of the main systems the primary task for VT02 was to develop the engine interfaces and engine control for serial production.

In autumn 1991 an actualized market survey led to different requirements. Especially the need for more seating capacity was clearly recommended. In addition with the merge of Aerospatiale's and MBB's Helicopter Divisions the full range of AS technology has been made available for this helicopter. Eurocopter's new light twin helicopter - now called EC135 - is the evolution of the BO 108 but with

- increased seating capacity without changing the outer dimensions drastically
- a completely new designed Fan-in-Fin anti torque system
- new designed main transmission in terms of housing material and height
- an improved low noise concept
- an improved BMR



The EC135 is also prepared to fulfill the certification requirements of the JAR27 with CAT.A option. E.g. no structural change has to be made to introduce a crash resistant fuel system. The basic design features are summarized in Fig. 3.

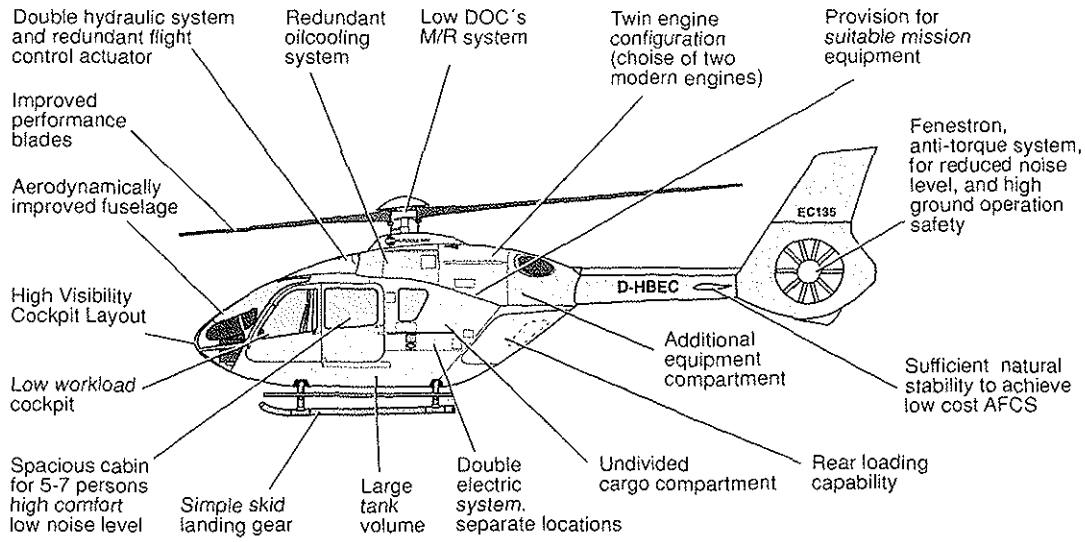

Fig. 3: Basic Design Features

Two main differences to the prototypes can clearly be seen. One is the new Fan-in-Fin anti torque System and the second is the additional window in the side shell necessary for the wider cabin size.

**1.2 Main Dimensions and Cabin Layout**

The Commercial Helicopter Advisory Team (CHAT) in which the main customers and operators of the western world had been involved gave a clear recommendation to extend the seating capacity of the BO 108. The customer must have an advantage in terms of seating capacity compared to the BO 105.

Therefore the cabin of the EC135 has been completely redesigned without dramatically changing the outer dimensions. The main dimensions are to be seen in Fig. 4.

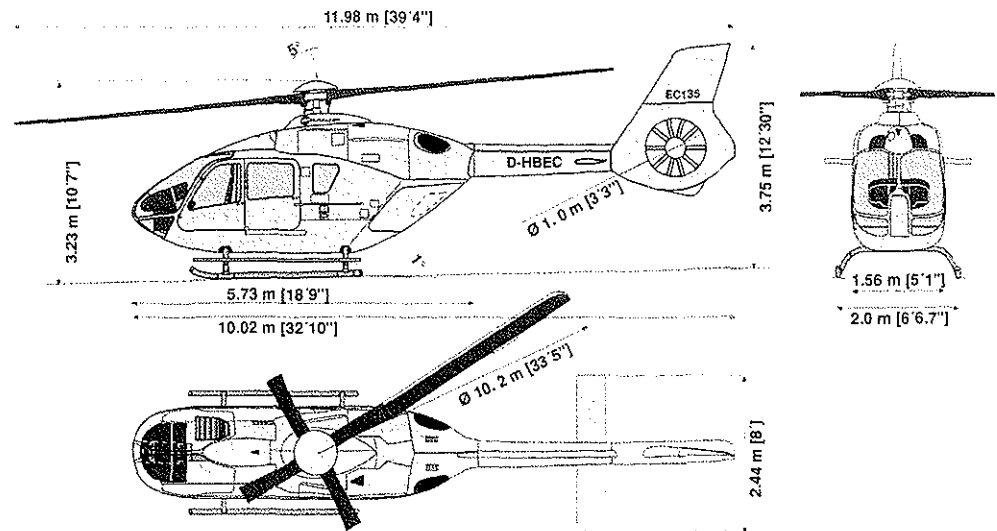

Fig. 4: Main Dimensions

The EC135 remains in terms of outer dimensions a small helicopter. The redesign of the cabin contents include:

- introducing a third seat row with additional windows in the side shells
- raising the transmission deck to give comfortable space to passenger on the 3rd row
- introducing a control post to avoid control rods in the side shells. The control post is located excentric just behind the left side of the pilot so that the pilots elbow will never have contact with the post. It is positioned in such away, that the pilots view backwards to the left (e.g. for winch operation) is not effected. He has the full view of the opened sliding door (Fig. 5). The cross section of the part is only 100 x 90 mm.

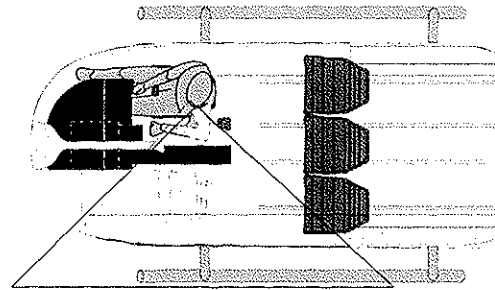

Fig. 5: Positioning of the Control Post

- increasing slightly the width of the cabin from 1.50 m to 1.56m
- giving the fuselage a more rectangular shape in the pax area with increased width and height in the shoulder area
- improving the pilots visibility by
  - „stretching“ the windows over the pilots head without disturbance by a cross bar which gives an excellent visibility in right turns for the pilot
  - reducing the non transparent area of the h/c nose
  - minimizing the size of the instrument panel

Fig. 6 summarizes the new design points

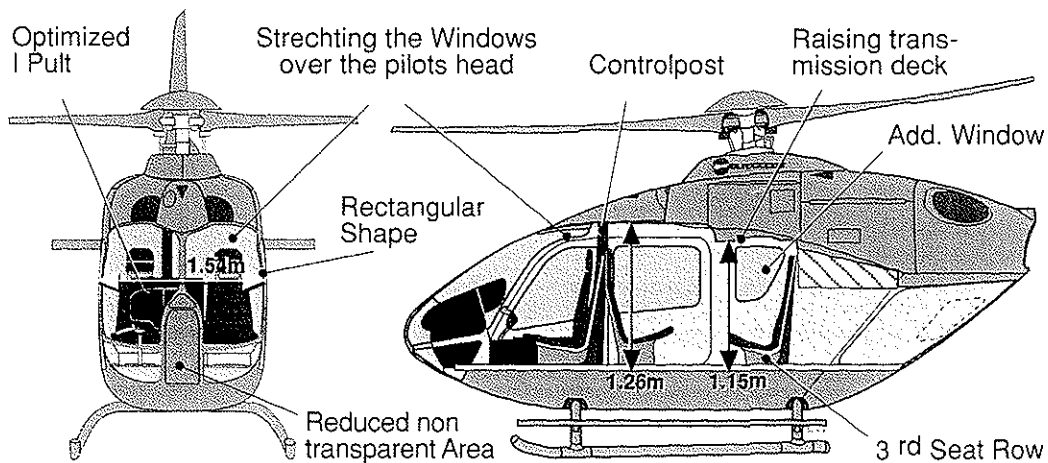

Fig. 6: Cabin Layout Redesign

The advantages of the BO 105/BK 117 layout like

- rear loading capability with two big clam shell doors
  - one level floor
  - good side loading capability by using one hinged and one sliding door on each side without disturbance by a door post
- are valid also for the EC135.

The cabin design gives the customer a maximum mission flexibility for

- pax transport with 7 seats and normal baggage compartment (Fig. 7)
- all versions of VIP transport
- police or law enforcement with 5 seats and an extended cargo compartment
- EMS with 2 litters, 1 pilot, 2 attendees, or 1 litter, 1 pilot, 3 attendees (Fig. 8)
- utility with 1 or 2 pilots with an extra ordinary cargo space in this weight class.

With this design the EC135 is now an even more multi purpose helicopter.

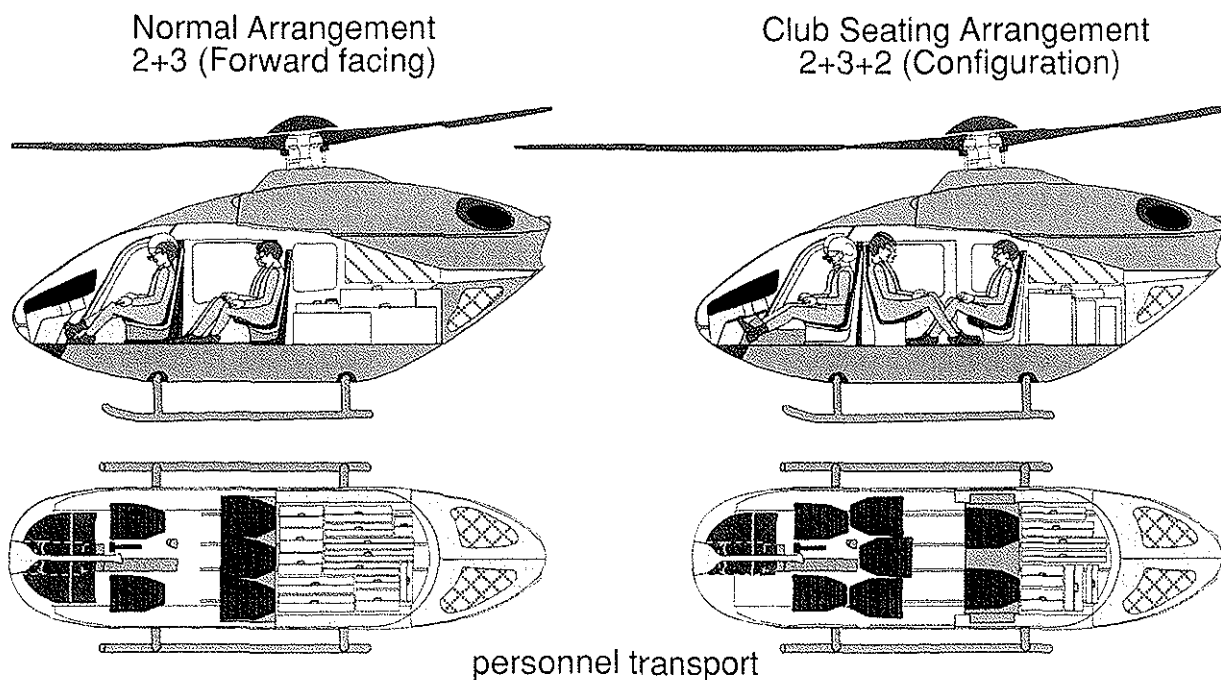

Fig. 7: EC135 Multi Role Cabin

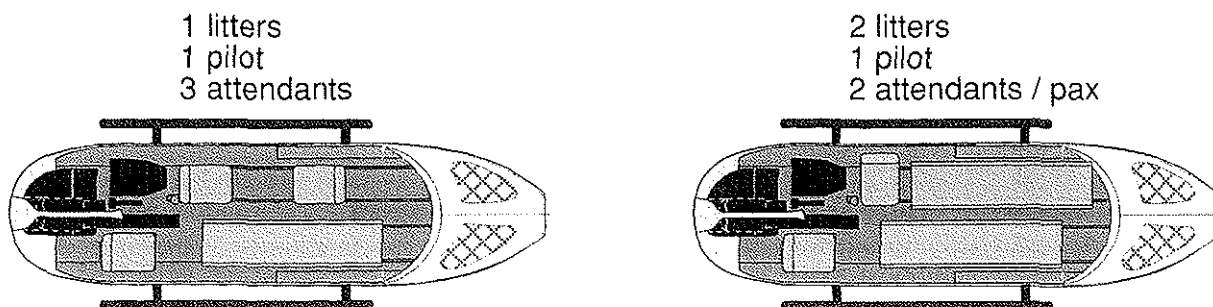

Fig. 8: EMS Version

The complete redesign of the cabin has been verified in a new exhibition mockup (Fig. 9). The response of the customers is exceptionally positive.



Fig. 9: EC135 Exhibition Mock up

A consequence in raising the transmission deck without changing the external dimensions has been a major redesign of the main gearbox. Also the clear requirement of the customers (CHAT demand) not to use magnesium for the housing results in a new housing design.

The MGB design changes include the following (Fig. 12 a, b)

- housing material changes from magnesium to aluminium alloy
- the oil sump has a flatter design
- the titanium plates with the fix points for the ARIS installation are completely integrated in the housing
- introduction of a second oil pump.

The MGB is designed and manufactured by ZF.



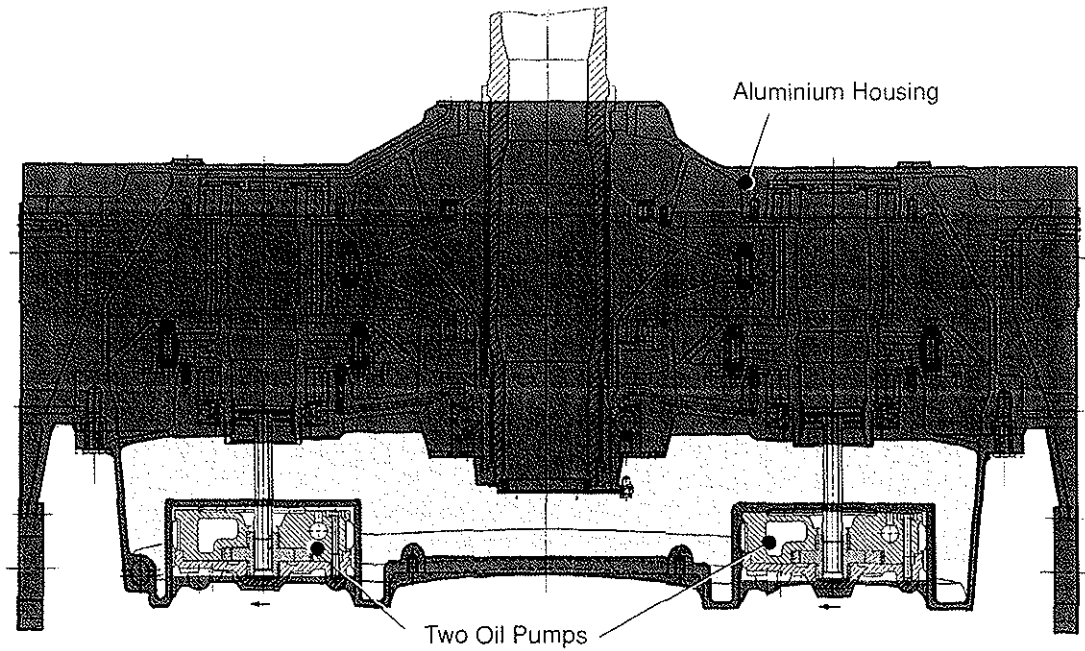

Fig. 12a: EC135 MGB Front View

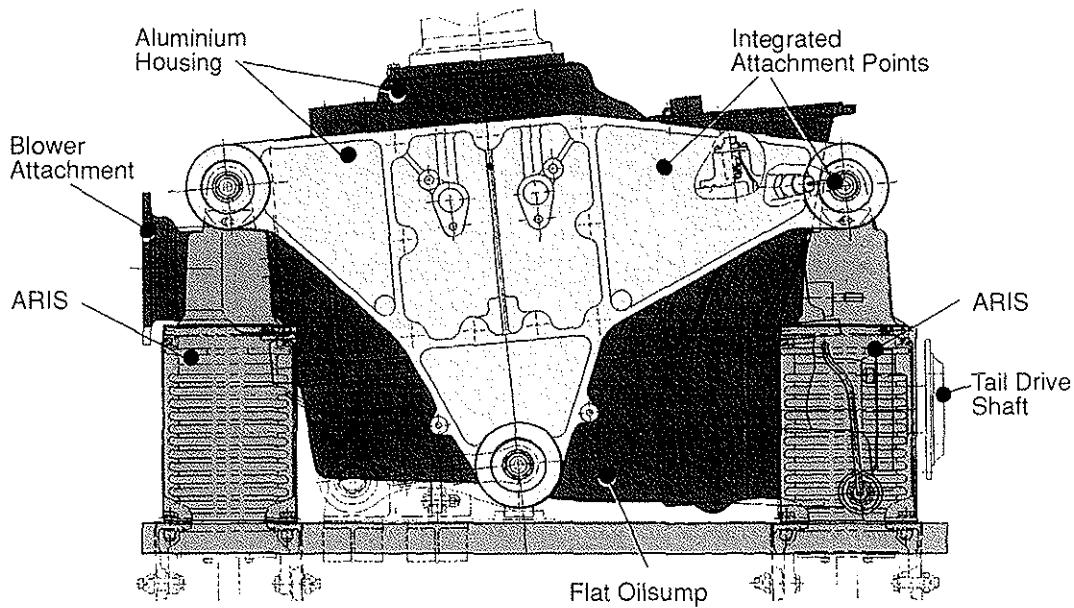
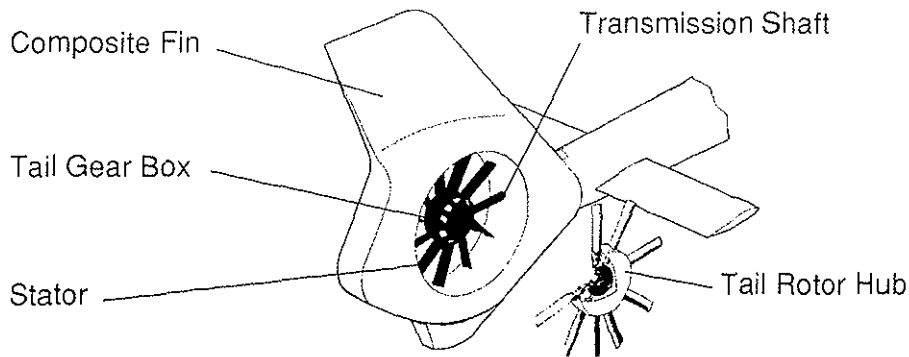

Fig. 12b: EC135 MGB SideView

The JAR 27 CAT A option requires a dry run capability of the MGB of minimum 30 minutes. ZF did a test run with the MGB of the VT02 type and reached over 60 minutes without destroying the gearbox.

### 1.3 New Anti Torque Fan-in-Fin System



The decision of Eurocopter Deutschland to use on the EC135 the new generation Fenestron Fan-in-Fin tailrotor was mainly based on two aspects:

1. The Fenestron is a proven concept and has been recognized as significantly improving the safety level.
2. The external noise requirements are more and more important. This aspect has been very early taken into account in the design of the new generation of Fenestron.

The safety aspect is answered by the concept itself.

The noise aspect is answered by the following improvements.

- phase modulation of the rotating blades (unequal spaced) to eliminate the whistling effect
- optimization of the stator position to the rotating blades
- diameter of the shaft
- improved airfoils

The main characteristics of the new Fenestron are (Fig.13)

- 1 m diameter
- 10 rotating blades
- 10 stator blades + 1 drive shaft
- no hydraulic necessary
- highly improved reliability by using
  - alloy blades with hard coating for erosion protection (30% better in sand than Gazelle blades)
  - increased chord (50 mm) and reduced tip speed will improve the erosion reliability by a factor of 2!
  - dramatical reduction of control loads (no hydraulic!) due to new airfoils with very low  $c_{mq}$ , new position of the pitch horn, increasing the embedment of the two axial bearings and introduction of chinese weights.

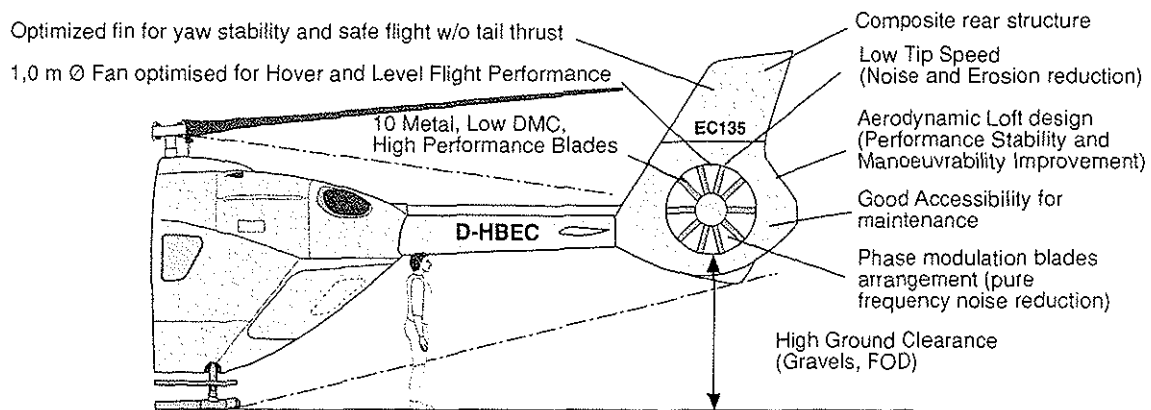

Fig.: 13 Main characteristics of the EC135 Fenestron

In [4] a very detailed presentation of the development and research as well as the test results of the EC135 Fenestron is given.

## 1.4 External Noise

Beside the effects on the Fenestron side, many measures have been taken to achieve the overall noise target of - 6 dB below current ICAO Annex 16 limits. These measures include:

- a lower main rotor tip speed of 211 m/s (at 100%  $N_{Rotor}$ ) which is equivalent with a Fenestron tip speed of 187m/s
- rotor blades with new generation DM-H3 and DM-H4 airfoil sections
- a parabolic tip geometry
- an aerodynamically clean fuselage which requires less thrust for a given speed which leads to less power and collective setting which reduces the blade shape.
- lower rotor hub drag which gives reduced hub wake interference.

The low noise requirements refer to the helicopter near ground (< 3000 ft). In high altitude (> 10000 ft) the noise is not such important. Taking this into account, the use of the digital controlled engines gives an additional advantage. In the EC135 the FADEC has a density altitude input and varies the turbine ( $n_1$ ) speed with this parameter. The dependency of the rotor speed with the altitude can be seen in Fig.14

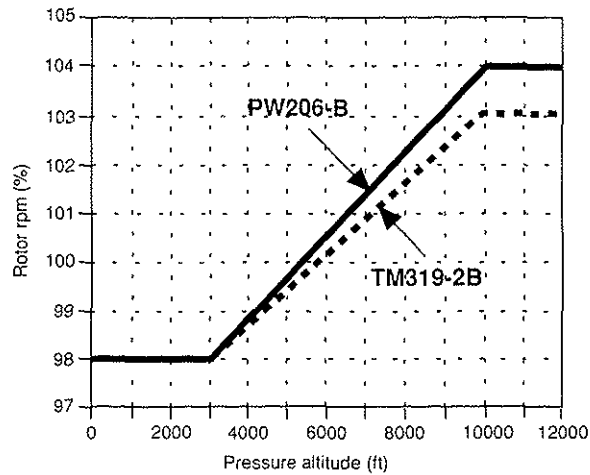

Fig. 14: Variable Rotor speed

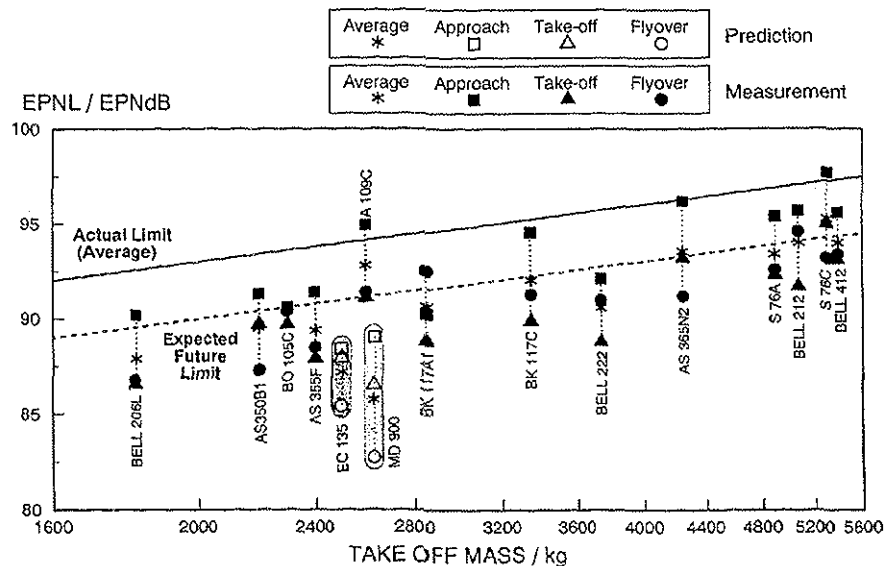

Fig. 15: External Noise Comparison

The result is a noise reduction of additional -1.5 dB at ground level. A comparison with existing helicopters is shown in Fig. 15. It is expected (and measurement with VT02 verified many measures) that the EC135 will be a low noise helicopter.

## 1.5 Improvements on the BMR

The BMR concept stays on the EC135, but several improvements have been introduced (Fig. 16). The diameter has been increased to 10.2 m with a parabolic blade tip. A rotor with these dimensions has already be flown on the VT02.

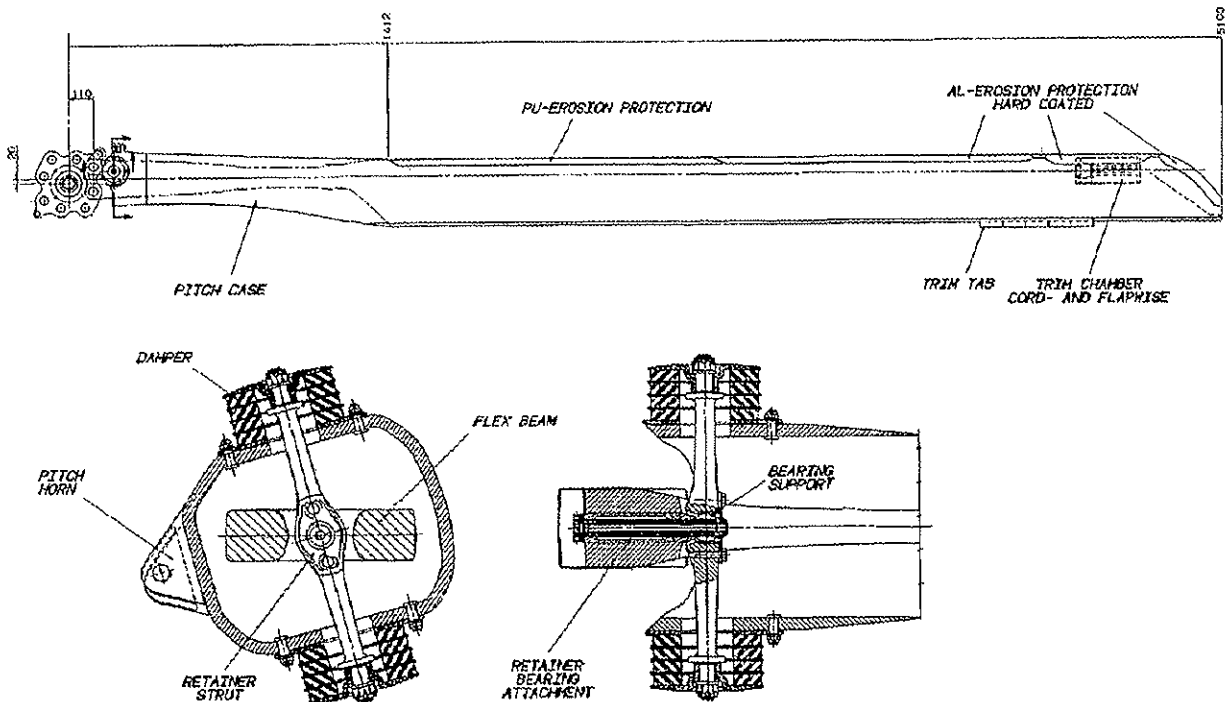

Fig. 16: Improvements on BMR Serial blade

A further improvement will be realised on the erosion protection side. Out of a joint ECD/ECF research and development program for better erosion protection the following results have been applied to the EC135. To get a perfect bonding between the metal strip and the blade an aluminium shield will be used. This reduces extremely the stress spike level in the bonding layer itself (E-Moduli are much less different compared to the combination with Steel or Nickel), has a much easier surface treatment, is weldable and easier to deform. On the aluminium shield a special two phase hard coating protects the leading edge of the blade. This protection will be used on the last 2 meters of the blade. An further improvement is the aerodynamically formed control cuff (drag!) and its attachment to the homogenous part of the blade. This attachment will guarantee a proper work of the elastomeric damper. A chordwise balance chamber and the fine balancing on the top of the control cuff closes the loop of improvements.

## 1.6 Performance

To give the customer/operator not only a quiet and spacy helicopter ECD will equip the EC135 with two powerful engines. One alternative is the Turbomeca Arrius 2B (which is a flat rated 2C Version) and the other alternative is the Pratt & Whitney PW206B (which is flat rated 206A).

The main data of these engines are summarized in Fig. 17 .

	Arrius 2B	PW 206 B
MCP	362 kw	372 kw
TOP	384 kw	388 kw
2.5 min. (OEI)	468 kw	442 kw
30 min. (OEI)	428 kw	388 kw
SFC (SL, ISA 300kw)	<370 $\frac{g}{kwh}$	<375 $\frac{g}{kwh}$
Weight	107 kg	115 kg

all performance values for SL, 25°C

Fig.17 : Engine Main Data

Due to the fact that there are minimal installation differences (only adaptation of harnessing, specific engine instruments and front fire wall adaptation is required) the customer can select his engine type at contract signature. The cowling for example is identical for both engine types. The common characteristics of the engines are:

- integrated oil tanks
- Full Authority Digital Engine Control (FADEC)
- 2 years or 2000 flight hours complete warrenty
- radial air inlet
- big growth potential
- integral rotor burst protection

In case of a double FADEC failure the engines can be controlled by a fully mechanical back up. It is located in form of twist grips at the collective pitch and operates directly the fuel metering unit versus a mechanical flex cable.

With these engines the EC135 will have excellent performance values. Fig. 18 shows the performance for all engines operating.

	Arrius 2B	PW 206B
■ $V_{max}$ (5000ft/ISA) max side ward speed (SL/ISA) max horizontal wind for start (SL/ISA) $h_{max}$ pressure altitude (ISA)	274 km/h	274 km/h up to 40 kts up to 40 kts 6000 m
■ Hover in ground effect (ISA/MTOW)	4800 m	4650 m
■ Hover out of ground effect (ISA/MTOW)	4200 m	4000 m
■ Max rate of climb (SL, ISA)	8,4 m/s	8,4 m/s
■ Max range (5000ft/ISA without reserve)	810 km	800 km

all data for MTOW

Fig. 18 : EC135 Performance (AEO)

The one engine inoperative performance will be (Fig. 19).

	Arrius 2B	PW 206B
■ Service ceiling (MTOW/ISA)	3750 m	3100 m
■ Hover out of ground effect (2000kg/ISA)	2800 m	2450 m
■ CAT A (Clear heliport/SL/ MTOW)	up to 54°C	up to 40°C
■ CAT A (restricted and elevated heliport)		
	MTOW/ ISA	2650 m
	MTOW/ SL	up to 50°C
■ Max rate of climb (SL/ISA)	2,7 m/s	2,7 m/s

Fig. 19 : EC135 Performances (OEI)

The temperature range (OAT) in which the EC135 will be certified is:

normal operating range: -30°C to +54°C

extended operating range: -45°C to -30°C

in this case special cold weather operation kit or provisions have to be used.

The combination of a low drag fuselage, improved performance and a fuel capacity of 700 l results in an excellent payload range diagram (Fig. 20). Baseline for this diagram is that EC engineers will achieve the basic empty weight target of 1340 kg.

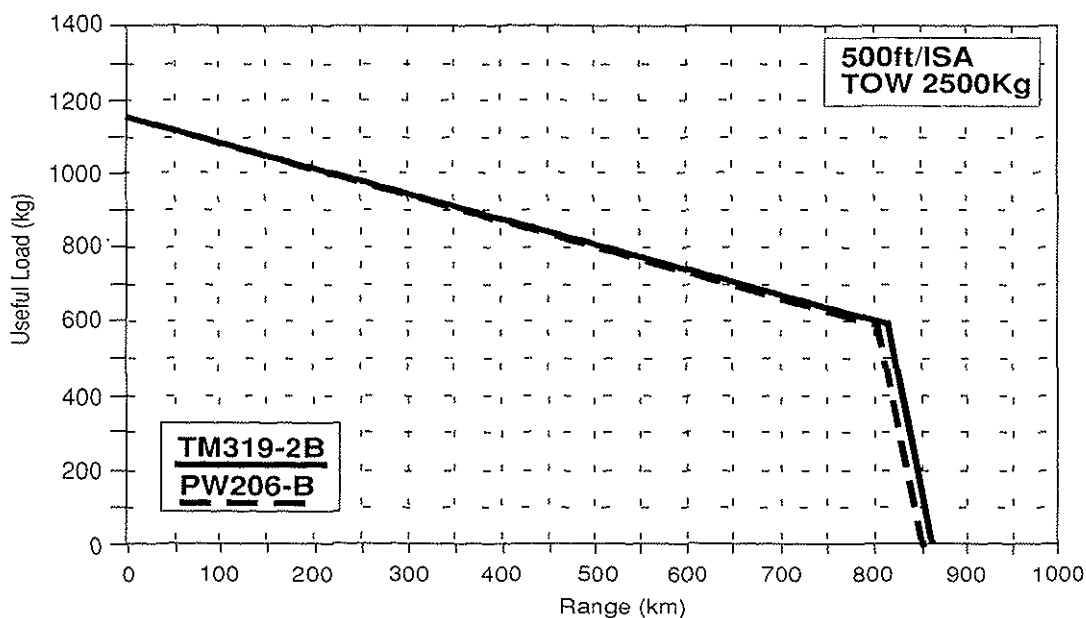

Fig. 20 : Payload Range Diagram

Special attention has been paid to the power consumption of the Fenestron .

Due to the fact, that the thrust capability of the Fenestron is higher than that one of a classical tail rotor (CTR) and the CTR Finblockage is more effective up to 50 kts sidewind than the Fenestron fin drag, the Fenestron is better in this condition (Fig. 21 and Fig. 22) .

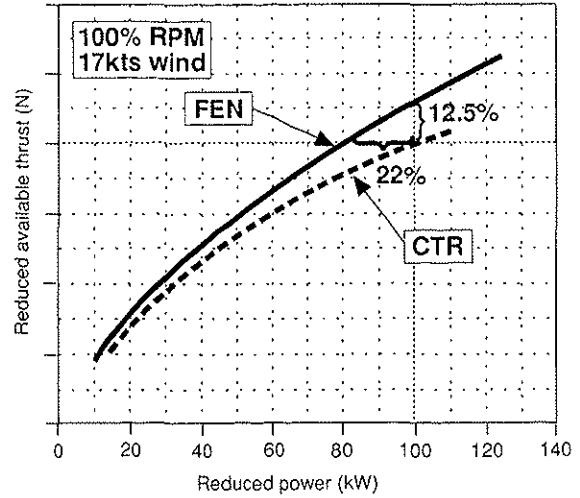
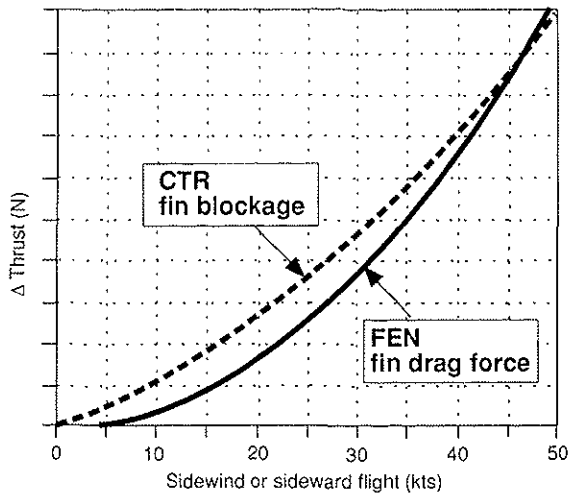

Fig. 21+ 22: EC135 Performance in Sidewind Conditions

For CAT A procedures the Fenestron has advantages for clear heliport and is equivalent for the restricted one (Fig.23 and Fig. 24).

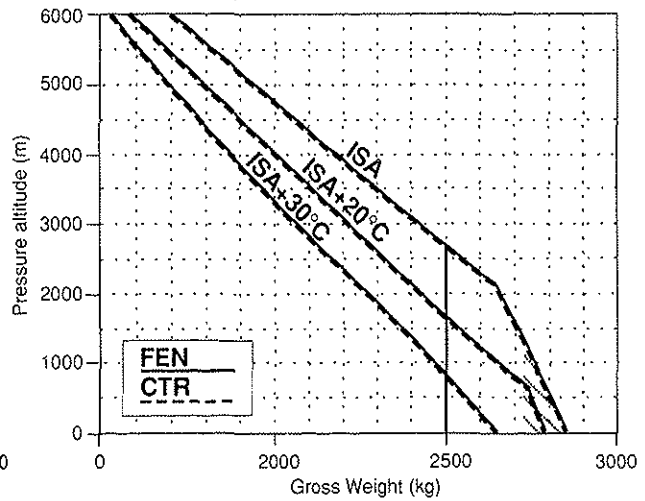
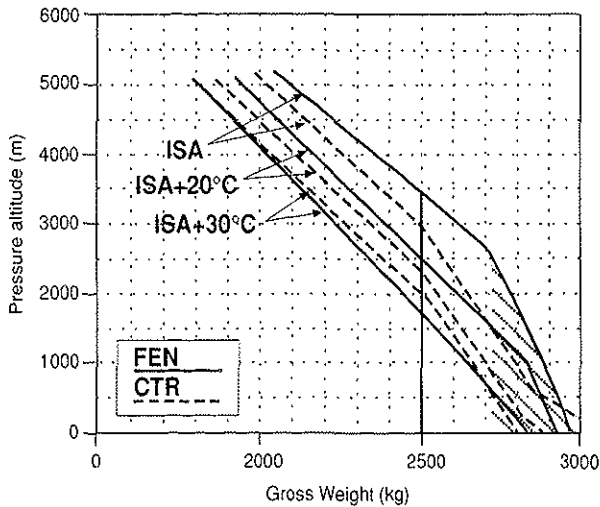

Fig. 23 + 24: EC135 CAT A Performance

The comparison with Max. Rate of Climb sees the CTR as winner. This effects of course the OEI service ceiling. The CTR gives ca. 8% better MROC which leads to 8% more service ceiling altitude (OEI). But due to the well sized overall performance ECD accepted this small disadvantage.

## 1.7 Cockpit Layout

The cockpit layout had been based on three main targets

- max. visibility for the pilot
- minimum work load
- low acquisition cost

The first point (visibility) could be achieved by using a full composite canopy frame which gives increased window area (Fig. 25 ). Special attention had been paid to the nose section. Compared with the BO 108 the transparent area had been well increased. The former requirement of an integrated weather radar had been dropped down for a better front/down visibility. A weather radar can be installed in any case by using a special „nose“. To improve the visibility above the pilot the windows had been „stretched“ far behind the pilots head.

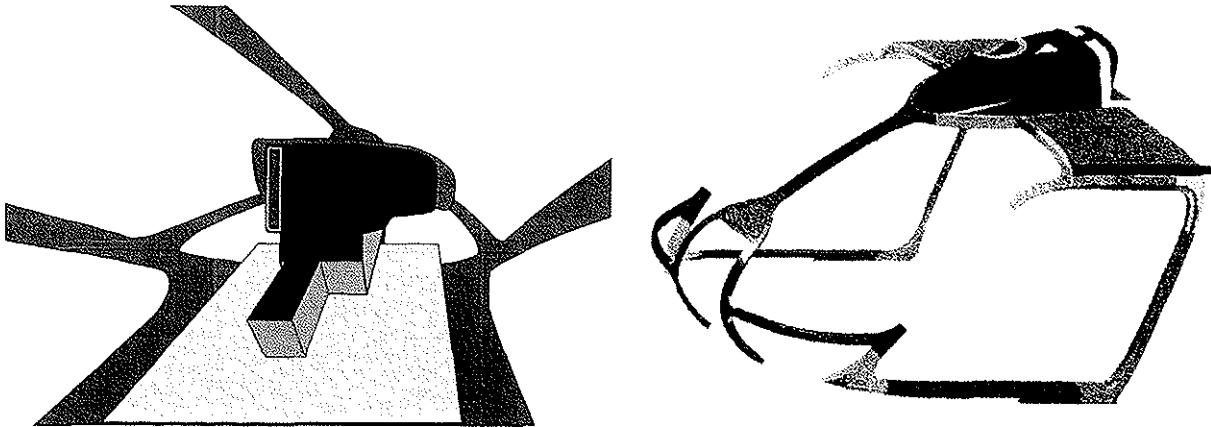

Fig. 25 : EC135 Pilots View

The main disturbance for the outside visibility is the instrument panel. Therefore the EC135 is equipped with a modular instrument panel. Fig. 26 shows the different configurations.

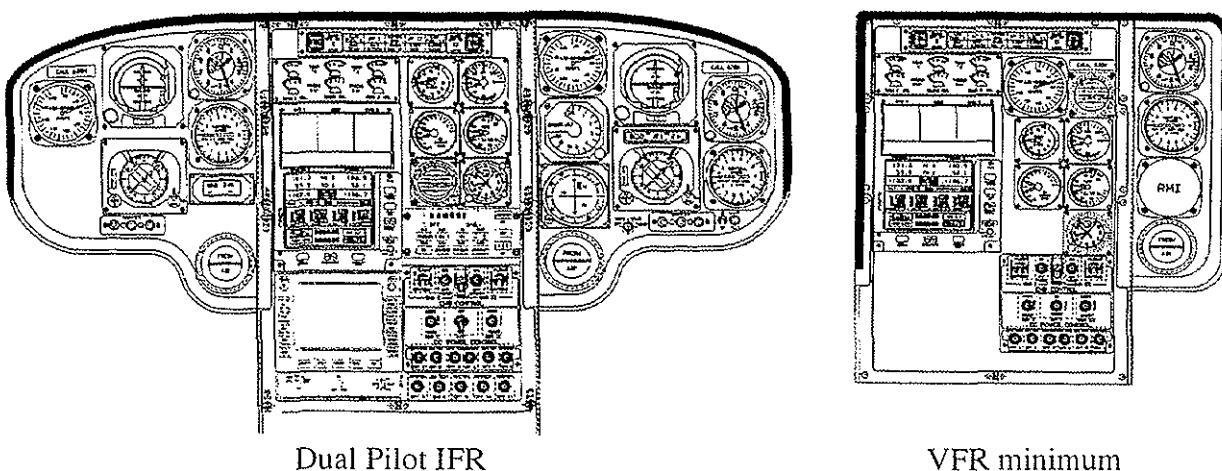

Fig. 26: EC135 Modular Instrument Panel



To drop down the acquisition cost a so called Cockpit Display System (CDS) has been defined.

It consists of

- caution panel
- advisory panel
- engine parameters indication
- indication of the electrical power system
- outside air temperature indication
- mast moment indication
- fuel capacity indication
- $V_{NE}$  for different weights
- as option:
  - cable length
  - hook load
  - radar altitude

Fig. 27 shows the layout

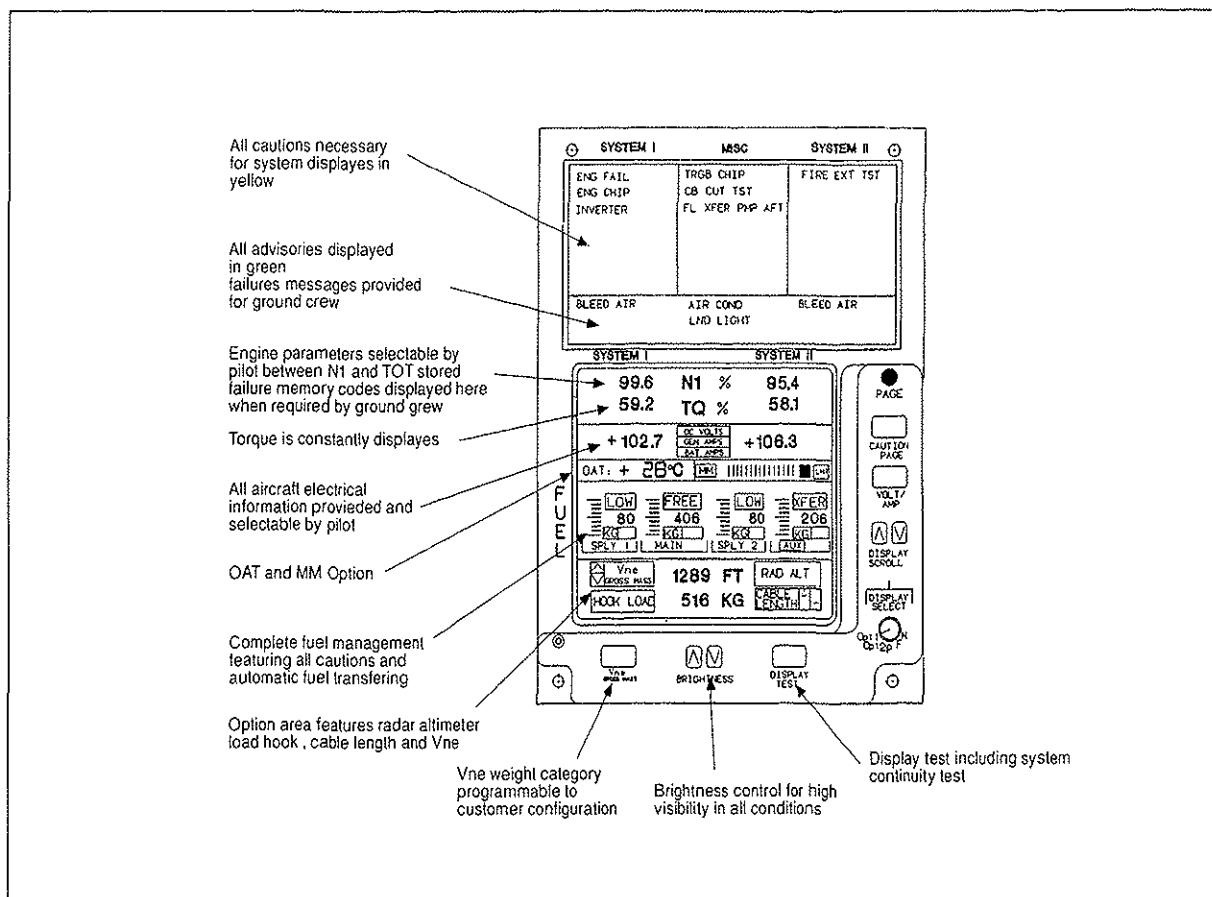

Fig. 27 : Cockpit Display System

EC is in the moment investigating, how a complete display cockpit could look like. The first step could be one display with an First Limit Indicator and the engine/MGB oil pressure and temperature indication.

In a second step two additional displays for the flight management could be installed. The last step could be a full glas cockpit with a 3 axes autopilot.

## 2. PROGRAM STATUS

Fig.28 shows the overall time schedule for the EC135.

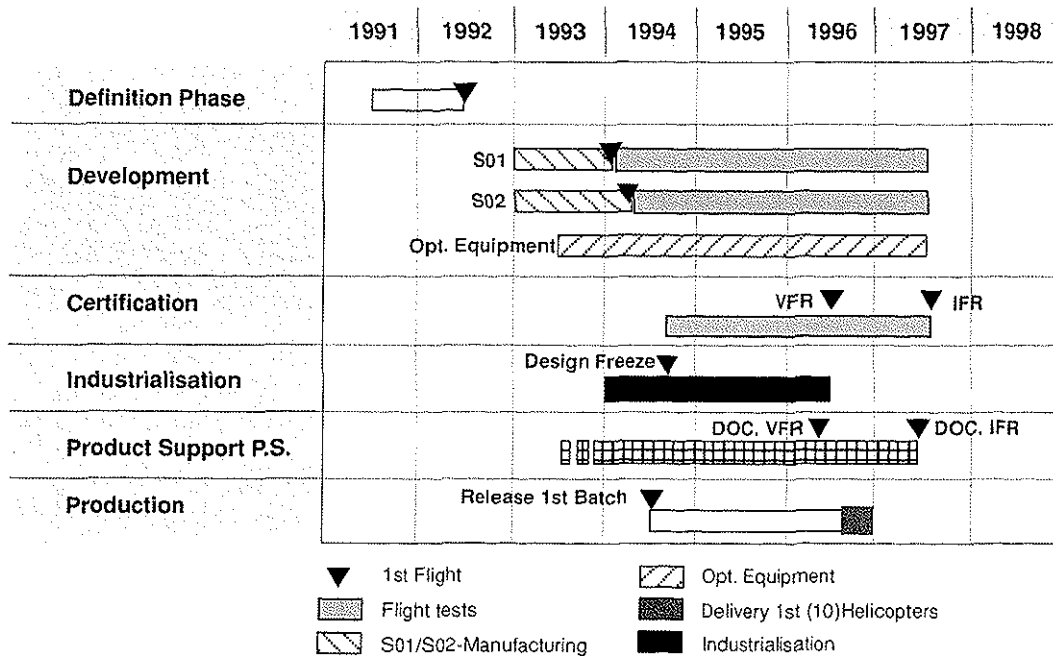

Fig. 28 : EC135 Time Schedule

It foresees the use of two preproduction aircrafts for the certification flights.

The first helicopter (S01) will be equipped with the Turbomeca Arrius 2B engine. Its first flight is foreseen mid February 1994. Basic flight tests will be finished within 5 months. The second helicopter (S02) will have the Pratt & Whitney PW206B engines. Its first flight is scheduled to beginning April 1994. Basic flight tests (mainly engine related) will take roughly 3-4 months.

To give the manufacturing plant enough time for the production preparation it is essential to do the Design Freeze of the drawings in the 3rd quarter of 1994.

To achieve the VFR certification it is necessary to start with the certification flights at mid 1994. The IFR certification is scheduled at early 1997.

To get a fast program and to ensure the first flight of the S01/S02 ECD decided to use an engineering class II mockup. Fig. 29 shows the equipped stage mid 1993.

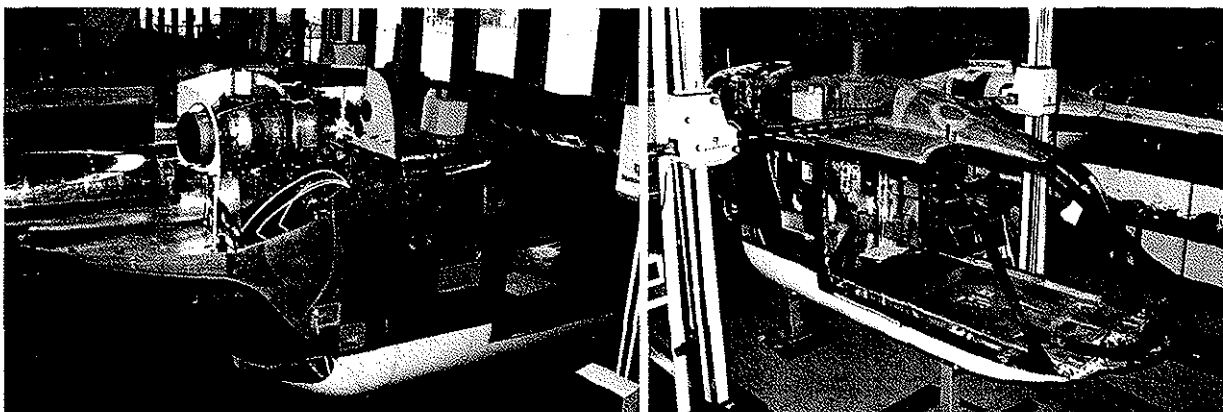

Fig. 29 : EC135 Engineering Class II Mock up

This mockup is equipped with mockups of MGB, hydraulic and engines but with flightworthy components

- all controls before the hydraulic
- electrical wiring
- instrument panel with all instruments
- heating and ventilation devices etc.

These flightworthy components will be transferred directly into the S01/S02. There will be a „prototype“ assembly line with class II Mockup, S01 and S02 in parallel. In this way the final assembly time could be dropped down from 12 months (VT01) to 5 months (S01).

In July 1993 the preassembled fuselage arrived from the manufacturing plant to the prototype shop (Fig. 30 ).

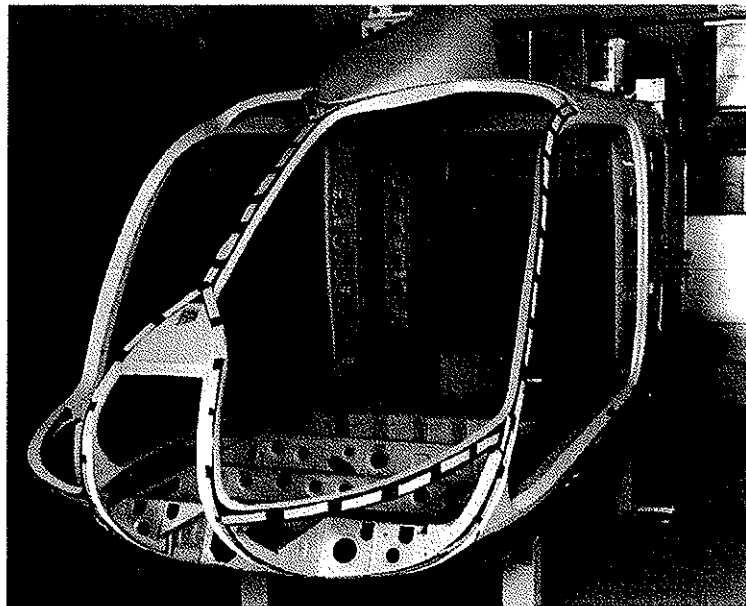

Fig. 30 : S01 Fuselage

The complete tail unit will be installed end October and the first ground runs will take place end of the year.

### 3. SUMMARY

In October 1990 the market response led to a complete redesign of the BO108. The main characteristics are now

- seat capacity up to 7 people
- new anti torque Fan-in-Fin Fenstron
- low noise design by the new Fenestron and the variable rotorspeed
- proven technologies on the BMR
- powerful FADEC engines (PW 206B or Arrius 2B)

With all these changes the first light twin from Eurocopter is called EC135.  
The main targets of this EC135 are

- low DOC
- low acquisition cost
- maximum mission flexibility
- excellent performance

It is planned to use two preproduction helicopters (S01/S02) for the certification flights  
The first flights will be:

S01: February '94

S02: April '94

Certification will be achieved:

VFR: early '96

IFR: early '97

Market introduction will be in mid '96.

## REFERENCES

[1] H.Huber and C.Schick, MBB's BO 108 Design and Development, AHS 46th Annual Forum, Washington D.C., May 1990

[2] H.Frommlet and C.Schick, Modern Technologies for Future Light Helicopters, 11th ERF, London, Sept. 1985

[3] D.Schimke, B.Enenkl, E.Allramseder, MBB BO 108 Helicopter Ground and Flight Test Evaluation, 13th ERF, Amsterdam 1989

[4] M.Vialle, G.Arnaud, A New Generation of Fenestron Fan-in-Fin Tail Rotor on EC135, 19th ERF, Cernobbio 1993