

**ADVANCED HEALTH AND USAGE MONITORING FEATURES  
OF MERLIN HC MK3**

**BY**

**M W HORSEY AND M J STUCKEY**

**GKN WESTLAND HELICOPTERS LTD  
YEOVIL, SOMERSET  
ENGLAND**

**23RD EUROPEAN ROTORCRAFT FORUM**

**SEPTEMBER 16-18, 1997 DRESDEN**

Date: Aug 1997

Ref: EH101/ERFW.002

**ADVANCED HEALTH AND USAGE MONITORING FEATURES  
OF MERLIN HC MK3**

**BY**

**M W HORSEY AND M J STUCKEY**

**GKN WESTLAND HELICOPTERS LTD  
YEOVIL, SOMERSET  
ENGLAND**

**ABSTRACT**

The Merlin HM Mk1 helicopter already has a sophisticated Health and Usage Monitoring (HUM) system. It has an unprecedented degree of integration with the helicopter avionic system and processed HUMS information is conveyed to the aircrew or a Ground-Based Data System (GBDS) according to its nature and status.

The customer for the Merlin HC Mk3 helicopter wishes to build upon the existing HUMS capability of Merlin Mk1. A particular area of interest is the advanced techniques of transmission vibration monitoring that GKN-Westland and others have developed in recent years, some of which are now being employed on a routine basis in commercial helicopter operations.

This paper illustrates the manner in which GKN-WHL are applying their HUMS experience to produce an enhanced HUM system for Merlin Mk 3. It is shown that with a minimum of disruption to the Merlin avionics architecture and on-board HUMS monitoring schedule, more transmission components will be monitored and a greater variety of analysis methods will be employed. Engine vibration monitoring will be introduced and rotor track and balance will become a totally integrated function.

On Merlin Mk3 the GBDS will be replaced by a very much more capable Health and Usage Diagnostic System (HUDS). This will perform the additional health monitoring calculations to support and extend the analyses available on the aircraft and thereby give increased guidance to maintenance personnel on the status of the aircraft and the nature of any maintenance required.

## **1. INTRODUCTION**

The MoD require the EH101 Support Helicopter, or Merlin HC Mk3, to be equipped with a comprehensive Health and Usage Monitoring System (HUMS). They wish to benefit from the advanced features of the HUM system fitted to the Naval variant of EH101, Merlin HM Mk1, but up-graded to reflect the latest HUMS technology as being demonstrated by GKN-WHL and others during the development and implementation of HUM systems on commercial helicopters.

As with any up-grading exercise there have been cost and time restraints and in the present case the up-grading has been constrained by a need to impose the minimum of change to the aircraft avionic architecture. This is particularly relevant to Merlin because the HUM system is not a modular addition but fully integrated within avionic architecture of the Aircraft Management System.

This paper illustrates the manner in which the HUM system on Merlin Mk1 has been enhanced both in terms of health monitoring technology and HUM system integration in order to meet the needs of the MoD for Merlin Mk3.

## **2. BRIEF OVERVIEW OF MERLIN HM MK1 HUMS**

The HUM system on Merlin Mk1 complements an extensive status monitoring facility that provides the aircrew with prioritized alerts when aircraft sensors identify abnormal modes of system behaviour and degraded operating conditions. The HUM system logs any 'warnings' that appear on the Central Warning Panel (CWP) and generates as well as logs 'cautions' that appear on the Electronic Instrument System (EIS). Only essential information is displayed to the aircrew, the majority of status data being recorded and down-loaded by the HUM system for the attention of ground-based personnel.

As well as providing additional status information for the aircrew and maintenance personnel, the HUM system performs health and usage calculations for the engines and transmission system, and usage calculations for the rotor systems and structure. The majority of health calculations are performed on the aircraft and the results are displayed to the aircrew if warranted or requested. Engine health calculations include Power Performance Index (PPI), and 'torque available'. Transmission health is monitored by Quantitative Debris Monitors (QDMs), bearing temperature measurements (critical bearings in the main gearbox) and vibration analysis of primary gears and transmission shafts.

Engine usage is computed on the ground station from down-loaded information relating to Low Cycle Fatigue (LCF), Creep Life and parameter-time exceedances. Transmission usage is computed from down-loaded torque-time information and the usage of critical elements in the rotor systems and structure is computed from down-loaded flight parameter and flight profile information.

Rotor tuning is achieved by the periodic employment of portable proprietary Rotor Track and Balance (RTB) equipment. This equipment also provides an indication of rotor and structural health.

### **3. Enhancements to Merlin Mk1 HUMS**

#### **3.1 Enhanced Transmission Vibration Monitoring (ETVM)**

Merlin Mk1 already has an advanced on-board TVM capability in terms of the on-board computation of vibration health monitoring parameters and the provision of alerts to the aircrew. The main or 'primary' gear train and shafts are targeted and the parameters computed from the frequency domain and time domain manipulations of synchronous time averages of shaft vibration. On Merlin Mk3, this on-board capability will be enhanced to more comprehensively monitor the tail drive shafts in flight and other changes in processing. More significantly, on-board TVM will be supported by additional signal processing on the ground station to extend the range of transmission components to be monitored and to extend the range of analysis techniques and health monitoring criteria to be applied.

As with Merlin Mk1, accelerometer signals will be acquired, processed and compared with thresholds in a near-continuous manner whenever the helicopter is operating within prescribed torque- and rotor speed windows. After a confirmation procedure, threshold 1 or threshold 2 exceedances of any TVM parameter will activate respectively a maintenance or caution message in the cockpit. In the event of a parameter exceedance, the values of all parameters at that time are stored in an exceedance log for trending purposes on the ground station. On Merlin MK3, the signal average files associated with an on-board threshold exceedance event will also be down-loaded for post-flight analysis. Irrespective of an exceedance, parameter values will be stored after each computing cycle on Merlin MK3 rather than the once per hour of Merlin Mk1.

On Merlin Mk1 there is an option for the aircrew to manually initiate the acquisition and down-loading of two complete sets of signal average files. On Merlin Mk3 the air crew will have an opportunity to initiate many more acquisitions (up to the capacity of the down-load device). In addition, there will be an automatic acquisition of complete sets of signal averages and samples of 'raw' vibration time histories for down-loading at hourly intervals, against optionally a two-engine operating or three-engine operating forward flight condition.

Ground station support for Merlin Mk1 TVM is principally the validation, display and trending of parameter values down-loaded from the aircraft, and the display of maintenance actions associated with any parameter exceedances. With Merlin Mk3 these facilities are retained but with the support of a considerable amount of extra signal processing. The on-board processing will be repeated but using an extended range of analysis routines and health indices. The processing will not be restricted to the primary gears and shafts but extended to encompass accessory gears and shafts, and transmission bearings. [Two extra accelerometers will be fitted to enable the monitoring of all bearings that support the tail drive shaft]. The on-board signal and processing checks will be supplemented on the ground station by further processing and scrutiny of snapshots of transducer signals gathered at the time when any on-board checks flag an alert.

### **3.2 Engine Vibration Monitoring (EVM)**

An engine vibration health monitoring capability will be introduced on Merlin Mk3. Two accelerometers will be fitted to each of the three engines and utilising two existing Tacho's per engine. The acquisition and analysis procedures will be similar to those employed for enhanced TVM. The focus of attention on the engines will be the compressor and turbine disks and shafts and the shaft support bearings.

An added feature for EVM will be the acquisition and analysis of frequency spectra at transient engine speeds. These spectra will enable a comparison to be made between the current installed vibration characteristics of each engine and those at the time of the original installation. The spectra will represent engine vibration in a form more familiar to maintenance personnel and the engine manufacturer.

### **3.3 Rotor Track and Balance (RTB)**

It was an important requirement of the customer that the portable equipment used for gathering rotor track and balance data on Merlin Mk1 be replaced by a permanent installation and the data acquisition and analysis activities integrated with other HUMS functions, including the analysis of down-loaded RTB data on a common ground station. Data is required to be acquired automatically by default but with an option for aircrew initiation. The eight accelerometers and two azimuths used for Merlin MK1 are again utilised, but the optical blade tracking camera is replaced by one suitable for permanent installation.

These requirements have been met on Merlin Mk3 with the most advanced RTB technology available. The optical blade tracking camera is embedded in the nose of the helicopter and has in-built signal processing to accomplish all of the data integrity checking and blade lead-lag track calculations. These results are appended to corresponding samples of blade vibration, the latter being gathered automatically in any of eight predefined windows of aircraft operation.

RTB processing on the ground station culminates in an unambiguous instruction to maintenance personnel of the nature and magnitude of any necessary adjustments to the set up of the main and tail rotors. It is not necessary that a complete set of RTB acquisitions are achieved in any flight as the rotor performance is trended over a sequence of flights and any omissions in the acquisition set can be estimated by comparison and extrapolation.

### **3.4 Structural Vibration Monitoring (SVM)**

On Merlin Mk1 the portable RTB equipment acquires vibration signals from an array of accelerometers over the structure of the helicopter. It then produces frequency spectra of the vibration at these locations for subsequent analysis purposes. Any changes in these spectra over the thresholds of normal variation are identified and interpreted as a possible indicator of a change in structural integrity, for example that induced by fatigue cracks or looseness of bolted assemblies.

The same SVM capability will be provided on Merlin Mk3 but using permanently installed instrumentation and signal acquisition and on-board pre-processing integrated with other HUMS functions. Final analyses and interpretation will be undertaken on the HUMS ground station.

#### **4. EHUMS Instrumentation**

Figure 1 shows the location of sensors that will be employed to gather vibration health data for Merlin Mk3 HUMS. The only change to the transmission instrumentation is that associated with the provision of two extra accelerometers on tail drive shaft hanger bearings. As mentioned elsewhere, there is a new requirement for 2 accelerometers per engine and the permanent installation of an Advanced Optical Blade Tracker (AOBT). All other accelerometers and azimuths are already present on Merlin MK1, but will have modified applications.

#### **5. Avionics Changes**

In order to handle and efficiently process the increased volume and diversity of down-loaded HUMS data the capability of the Merlin Mk1 avionics system has had to be enhanced. The enhancement may be regarded as an extension and up-grading of the on-board TVM function (see Figure 2).

On Merlin Mk1, the acquisition and processing of TVM data is managed by an Aircraft Management Computer (AMC). The AMC gives acquisition instructions to a Sensor Interface Unit (SIU). The SIU performs any necessary signal conditioning and fully processes the health monitoring data to the point where the values of health monitoring parameters, data files and status information are prepared for onward transmission. The AMC accesses the TVM data and compares the values of health monitoring parameters with pre-defined thresholds. The AMC triggers appropriate messages to be displayed to the aircrew such as caution messages on the EIS and/or HUMS status information on pages of a Common Control Unit (CCU), the CCU being the interface between the aircrew and maintenance personnel with the AMC. The AMC also controls the transfer of HUMS data for down-loading via a Data Transfer Device (DTD) to a 1 MB Data Transfer Cassette (DTC).

HUMS data is managed in a similar way on Merlin Mk3 but the SIU used for TVM has been redesigned to accommodate more input channels, faster and more diverse signal processing and preparation of more part-processed data files for down-loading. The processing capability and memory of the AMC has been increased and it now controls the transfer of data to a 40 MB PCMCIA down-loading card.

The on-aircraft HUMS functions can be modified either via the PCMCIA card or by an AMS software release, depending upon the nature of the changes.

## **6. Ground Station**

The ground station on Merlin Mk1 is referred to as the Ground Based Data System (GBDS). The GBDS processes health and usage data that has been down-loaded from the aircraft on the Data Transfer Cassette or has been entered directly by the aircrew and maintenance personnel. The aircrew use the GBDS to comment upon and confirm the serviceability status of the aircraft, and to formally hand over the aircraft to the maintainers. The GBDS informs the maintainers of any scheduled maintenance actions that are pending and any unscheduled maintenance activity that is needed in response to HUMS arisings. Any inspection arisings and repairs or alterations to the aircraft are logged and a log card is produced to accompany any component removed from the aircraft for repair or overhaul. There is communication between the GBDS and other systems including other ground stations, spares provisioning, logistic support and repair and overhaul organisations.

On Merlin Mk3 the ground station is referred to as the Health and Usage Diagnostic System (HUDS). The GBDS functions are retained but extended to accommodate the greater volume and variety of health monitoring data down-loaded from the aircraft as mentioned above. Correspondingly, the capacity of the Data Transfer Cassette has been increased.

## **7. Confidence**

Finmeccanica (Agusta) have designed and are responsible for the on-board TVM facility on Merlin Mk3 as on all variants of EH101. They have qualified their techniques through an extensive programme of test rig and aircraft monitoring. The rig testing has included seeded fault testing of critical transmission components as well as the monitoring of transmission rigs during the normal course of transmission testing and development.

GKN-WHL will be providing the signal processing algorithms for ETVM and EVM. These will be a derivative of algorithms that GKN-WHL have developed for commercial helicopter operations and which are currently being implemented on many helicopter types world-wide. The algorithms are being further refined in order to benefit from first-hand experiences with the monitoring of EH101 over a long period of rig and aircraft testing.

Algorithms for Rotor Track and Balance are being supplied by MJA Dynamics, another organisation who are intimately involved with the development and implementation of the technology in integrated helicopter HUM systems.

## **8. Conclusion**

Merlin Mk3 will have a HUM system that is generically similar to that employed on Merlin Mk1 but with an enhanced capability and a greater integration of HUMS functions.

Changes to the aircraft avionics system will be reduced to a minimum and mainly concern the acquisition of additional data for analysis on the ground station. The extra sensors and enhanced on-board processing capability required to perform these acquisitions will not only benefit ground station activities but be utilized to expand the on-board health monitoring functions inherited from Merlin Mk1.

The extra processing capability within the HUDS ground station in combination with the additional health monitoring data down-loaded from the aircraft will provide a very much more comprehensive assessment of the health of aircraft components and also of the status of the monitoring systems themselves. Amongst the benefits will be a clearer directive to maintenance personnel of the implications of any condition alerts registered on the aircraft and additional health information to that computed in flight. The health monitoring routines will be implemented in such a manner that, should the need arise, techniques can be transferred between ground station and aircraft with the minimum of inconvenience and re-qualification.

## **9. Acknowledgements**

The authors wish to acknowledge the support and enthusiasm of the MoD and in particular SH(EH101)ILS in endeavours to advance the technology of helicopter health monitoring.





GKN Westland  
Helicopters

### TRANSMISSION AND ENGINE

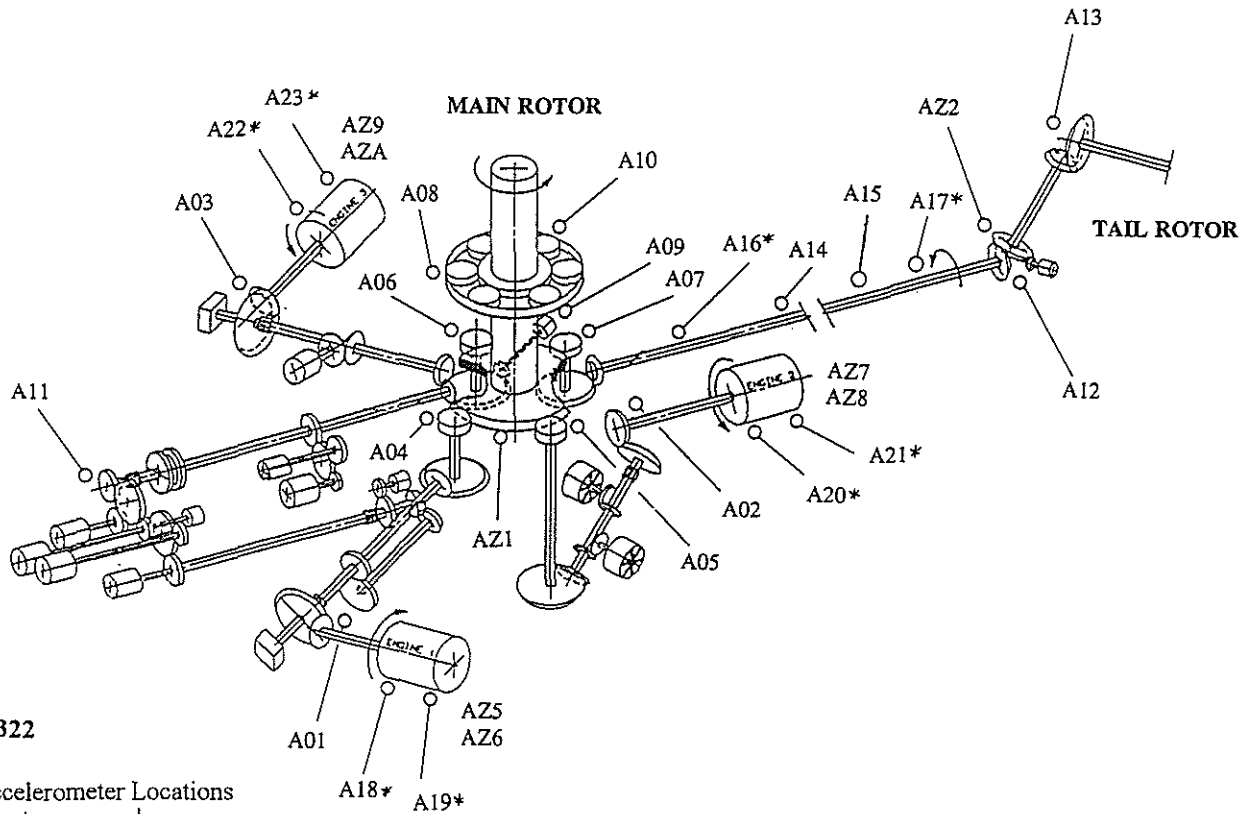

RTM322

Accelerometer Locations

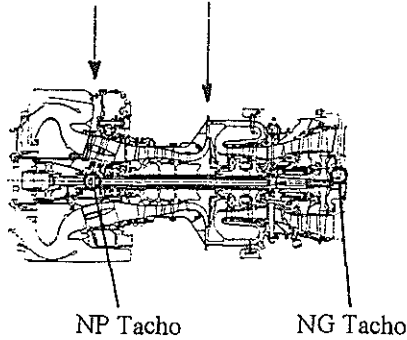

### STRUCTURE AND ROTORS

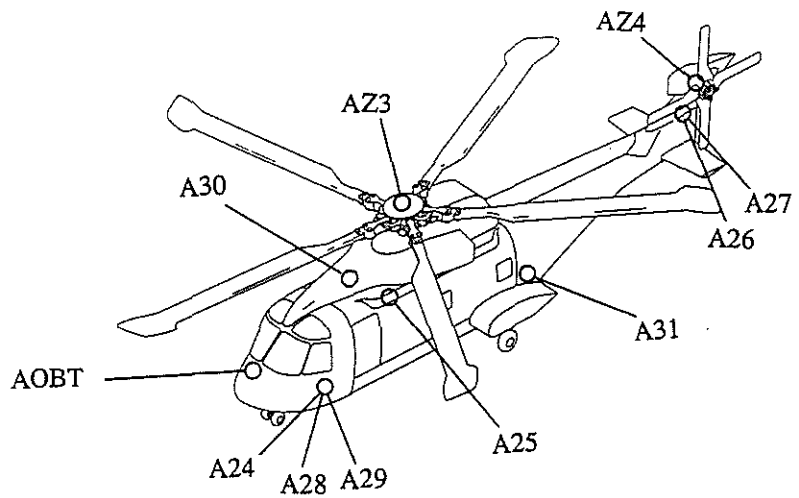

A = Accelerometer  
AZ = Azimuth / Tacho  
AOBT = RTB Camera  
\* = Additional Sensor for MK3

## EH101 MERLIN MK3 - ENHANCED HUMS VIBRATION MONITORING SENSOR LOCATIONS

FIGURE 1



GKN Westland  
Helicopters

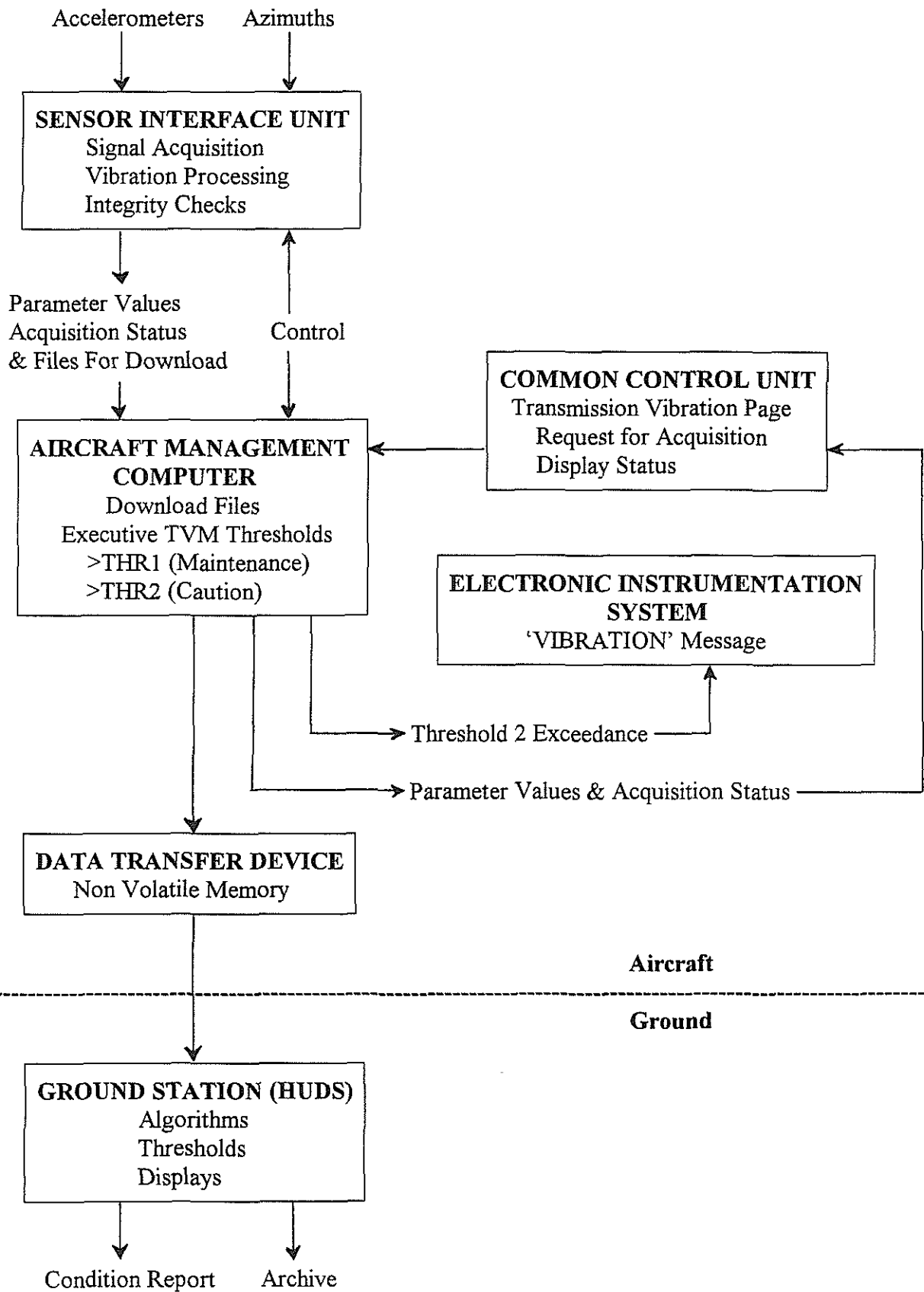

**EH101 MERLIN MK3 - ENHANCED HUMS  
INTEGRATION OF EHUMS WITH MERLIN MK1 TVM**

**FIGURE 2**