

TWENTYFIFTH EUROPEAN ROTORCRAFT FORUM

Paper No. F4

HELICOPTER MODULAR AVIONIC CONCEPTS

by

Alan Perkins
GKN Westland Helicopters Limited
Yeovil, Somerset, UK

SEPTEMBER 14-16, 1999
ROME
ITALY

ASSOCIAZIONE INDUSTRIE PER L' AEROSPAZIO, I SISTEMI E LA DIFESA
ASSOCIAZIONE ITALIANA DI AERONAUTICA ED ASTRONAUTICA

1. INTRODUCTION

GKNWHL have been conducting studies and assessments over a number of years concerning the development of flexible, integrated, modular helicopter avionic systems. Future avionic systems are expected to have evolved from the federated types, seen on platforms such as Merlin Mk1 and Heliliner, to integrated modular types in the next generation of future maritime, military transport and civil helicopters. This move is the result of a number of pressures on the aerospace and avionics industry to address issues such as controlling life cycle costs, overcoming obsolescence, and providing increased functional performance and flexibility within tight budgetary constraints.

Future developments in aircraft avionics also have to take into account the rapidly changing microelectronics market. Aircraft in service now and those due to enter service in the near future are faced with the prospect of electronic component obsolescence and subsequent supportability problems. The problem is made worse by semiconductor manufacturers withdrawing specialist support for the small volume market that avionics represents to concentrate on the high volume commercial markets driven by the expansion of personal telecommunications and computing. This paper examines some of the key issues that GKN Westland Helicopters (GKNWHL) have been addressing in their efforts to understand the changes that will be necessary for future systems and to identify an effective solution. Like many other companies in the aerospace community, GKNWHL are looking at the concept of modular avionics for the solution. This paper considers how the modular avionic concept could be applied to future versions of the EH101 helicopter.

2. MODULAR AVIONICS

Modular avionics promotes the use of common, standard components. The concept involves defining standard software components and a limited range of common hardware modules. The modular approach encourages the use of "open standards" which are expected to come from the commercial market and are ideally long lived. The standards are required to fit in a framework, see Figure 1, with well defined hardware and software interfaces as appropriate between the application, operating system, hardware drivers and hardware. These open standard interfaces enable elements of the system, in particular the hardware, to be replaced by newer designs and thus deal with obsolescence.

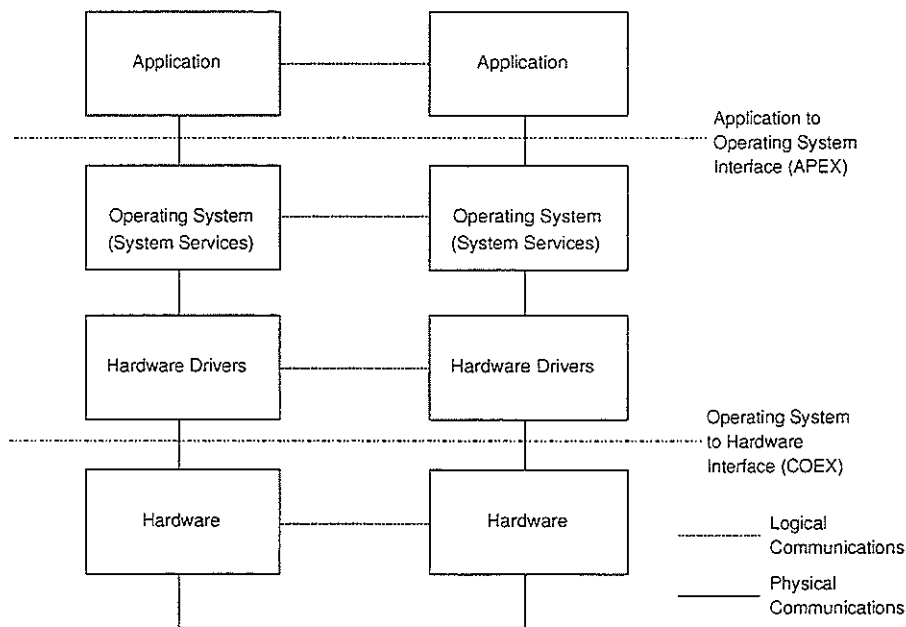

Figure 1 Framework for Open System

The standard components are designed for use across a range of platform types and are thus interchangeable and reusable. This is of particular benefit to a multi-role platform such as the EH101 where a number of versions could be in service with the UK armed services and civil operators. For a platform that may be in service for up to 30 years, the flexibility offered by a system that conforms to the open system framework is particularly important.

Modular avionics means different things to different people, it not only promotes the concept of common hardware and software with established interfaces defined by the framework, but presents a number of other options and challenges as well. These include:

- greater functional integration – requiring techniques to protect functions from each other if they are running on the same hardware module.
- mixing solutions from different vendors – the infrastructure created for the modular system should enable software functions from different vendors to be hosted on the same hardware module, or at least in the same enclosure.
- reconfiguration – enabling the introduction of maintenance free operating periods.
- new packaging concepts – enabling space and weight to be minimised.
- the use of “smart” localised resources – taking the digital domain out to sensors and effectors.
- incremental qualification and certification – allowing changes such as the addition, modification or removal of functions to be achieved without having to undertake significant re-test of the system.

The above list, the framework and the “openness” are the key elements of a modular system. The problem faced by aerospace companies is how to realise a modular system and which of the modular features listed above should be implemented. The drivers for this are cost and ability to meet operational requirements. The usual model for this position is represented by the cost versus capability curves as shown in Figure 2.

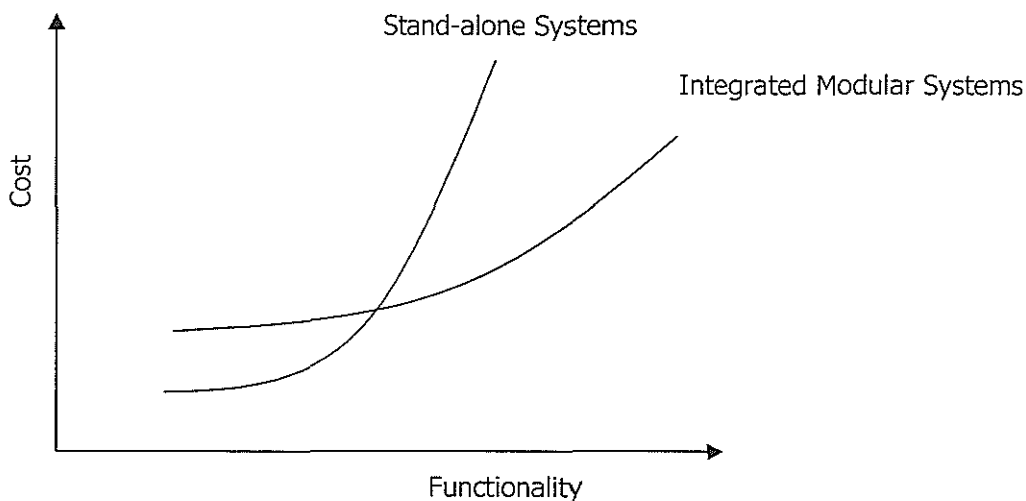

Figure 2 Cost Versus Capability Curves

The curves suggest that investment in moving from a non-modular system to a modular system will result in cost savings in the longer term as capability can be enhanced in the modular system at less cost than in a non-modular system. GKNWHL, through their studies, have been testing this relationship to understand whether the promised advantages will be realised.

3. BACKGROUND

An example military EH101 system is shown schematically in Figure 3. It comprises a core element which is broadly common to both civil and military variants and features:

- Aircraft Management System
- Electronic Instrument System
- Automatic Flight Control System
- Navigation System
- Communication System

These core systems are interconnected in military variants using a combination of MIL-STD-1553B and ARINC 429, and in civil variants using ARINC 429.

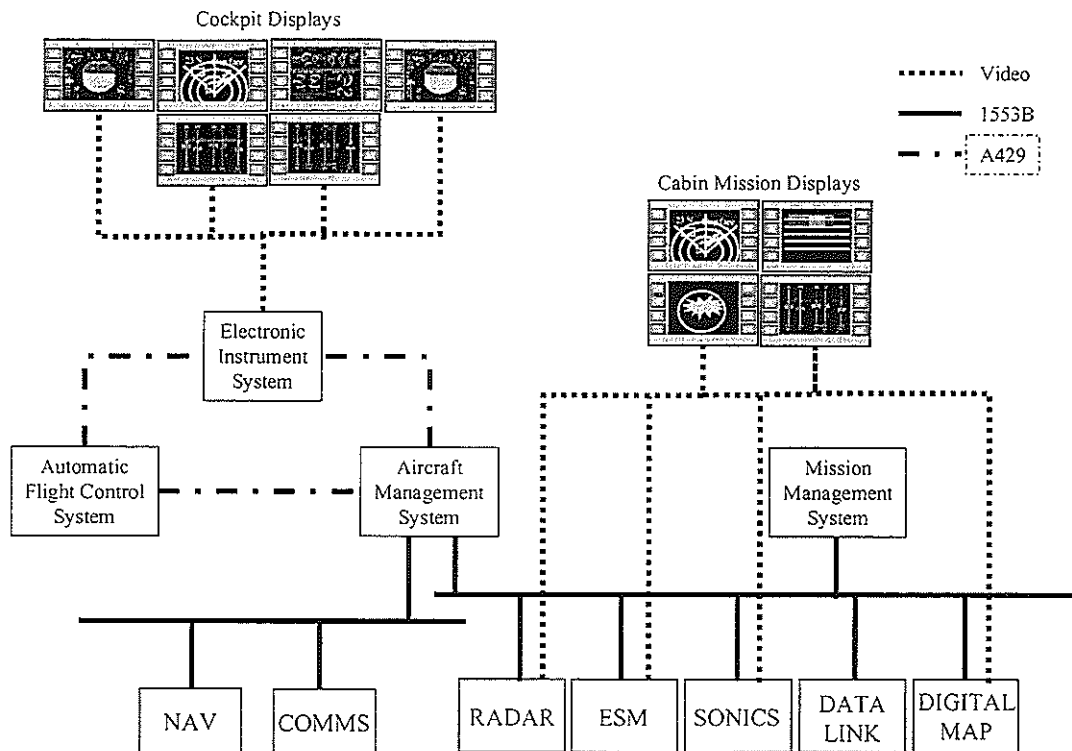

Figure 3 Current EH101 Architecture

Some of the variants, principally the military, feature a mission system fit. It is conceivable that a non-military variant could have a mission system of some form, perhaps a radar console in support of fisheries protection for example. The two EH101 variants entering service with the UK armed forces are the Merlin HM Mk1 and HC Mk3.

The Merlin HM Mk1 mission system features:

- Mission Management System
- Radar System
- Active Dipping Sonar
- Sonics System
- Data Link
- Digital Map
- Electronic Surveillance Measures

The Merlin HC Mk3 mission system features:

- Forward Looking Infra-red
- Defensive Aids

These mission systems are interconnected using a combination of MIL-STD-1553B and ARINC 429.

All EH101 variants feature complex video distribution systems managed by the Electronic Instrument System for the flight displays in the cockpit and from mission related graphic generation devices for the mission displays in the cabin and the cockpit, these can be seen in Figure 3.

3.1. FUNCTIONAL INTEGRATION

Avionic systems have become evermore sophisticated, with aircraft such as the Royal Navy's Merlin HM Mk1 incorporating radar, sonics (both active and passive), electronic surveillance measures, digital map and data link in the mission system. The task of managing these resources requires careful system design to ensure that workload is manageable, both in the cabin and the cockpit. For future systems with greater functionality, it is expected that the crew interface and support systems will develop to ease the workload. The result is functional development which requires ever closer integration of the various systems, particularly through the mission management system. GKNWHL's aim is to ensure that the functional integration is achieved in a cost effective manner and is supportable in-service, accommodating changes as a result of customer desires and technological development.

3.2. FLEXIBILITY

Flexibility is a key requirement for future aircraft, and this is particularly the case for helicopters. Customers are looking for products that are:

- Cheaper to acquire and operate.
- More flexible in use, to maximise the return on a relatively expensive asset.
- Easy to modify and adapt to take on new roles and satisfy changing requirements.
- More effective, without increased cost.

GKNWHL perceive the EH101 as providing a very flexible yet adaptable asset. Avionic system development towards a modular avionic solution is seen as potentially enhancing the flexibility by enabling rapid changes of role with the removal of equipment when the role change requires it, even with the higher level of functional integration expected of future systems. An IMA system would support this change in configuration through the developments in the software architecture with well established interfaces, particularly between the application and operating system, and with configuration management functionality within the operating system. Thus a change from an anti-submarine warfare role to a search and rescue role would see the removal of equipment from the cabin to provide additional space. The reversal of the role would involve re-instatement of equipment. In both cases there would be a need to run quick and effective test routines to validate system operation in the changed role.

The flexibility required of the avionic system extends to the sensor equipment fit itself. There is the need to be able to offer customers the option of fitting their preferred sensor systems, while retaining the overall integration and ultimately performance of the complete platform. The choice of sensor fit is very often driven by the desire to support specific industrial organisations and to provide a degree of offset that will help secure the sale of the helicopter. Once again, the software architecture will play a key role in enabling application software to be readily adapted.

4. SOFTWARE ISSUES

The framework for open systems shown in Figure 1 supports a software architecture that encourages the development of applications which exhibit independence from the hardware platform. The key feature of such a software architecture is the application interface, as shown in Figure 4. There has been much work to develop this application interface which in the long term will enable software re-use. The operating system that underlies the interface is also expected to support multiple applications in protected partitions, ensuring that at run-time, memory protection is achieved which guarantees the integrity of the applications.

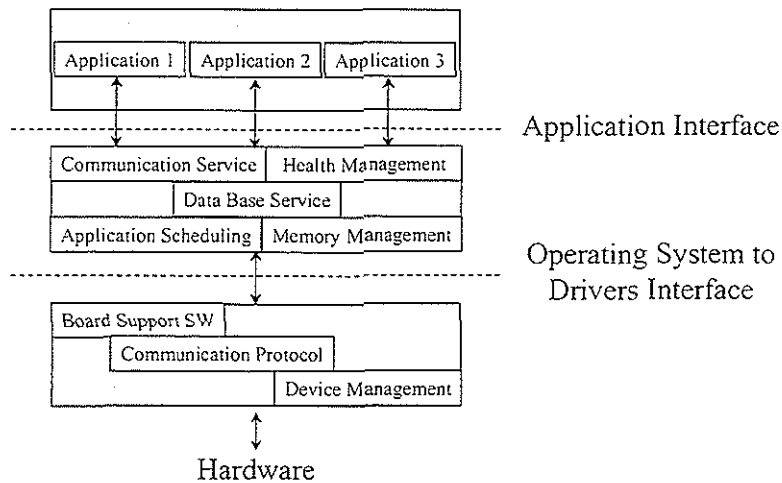

Figure 4 Example Software Architecture

5. MODULAR AVIONIC SYSTEM PROJECTS

Integrated modular avionics has been the subject of much study and some trials, with efforts taking place in the UK supported by the Ministry of Defence and by the Department of Trade and Industry through the CARAD budget. There have also been considerable efforts in the US, where platforms such as the F-22 Raptor the RAH-66 Comanche and the Boeing 777 have led the way with modular avionics systems. The key elements of these modular systems are:

- Common modules – both hardware, software and communication
- Common interfaces – ideally conforming to an open standard
- Functional integration
- Reconfiguration
- New packaging concept

The various modular avionics system projects present a number of options to the avionics system designer, making the task more difficult in determining the route to implementing a modular system from the currently available systems or those under development. Some of the options include the adoption of truly commercially derived technology (i.e. VME), the US military modular technology as proposed for F-22 and RAH-66 (although the commonality between these two platforms has been difficult to maintain), civil IMA as defined in ARINC 651 and its associated documentation and the European military solution being pursued through the Allied Standard Avionics Architecture Council (ASAAC).

5.1. US PROGRAMMES

The US military technology, based around the Standard Electronic Module type E (SEM-E) supports the key elements of an IMA system, but is based around two data bus standards that are unlikely to find continued support beyond the F-22 and RAH-66 programmes. These standards are the AS4704, High Speed Linear Data Bus and the AS4711, PI-Bus, both developed through the Society of Automotive Engineers. Developments in support of the Joint Strike Fighter will determine the long term viability of these bus standards, but it seems unlikely that they will feature in that programme.

5.2. ARINC EFFORTS

ARINC standardisation of IMA through the 600 series has not yet provided the infrastructure to fully support the development of IMA for civil aerospace systems. The Boeing 777 took the first step, but again the use of two data buses, ARINC 629 and ARINC 659, bespoke aerospace

solutions, has not been followed by other aerospace companies. The cost to connect to ARINC 629 is considered by many to be prohibitive and neither are truly open standards.

5.3. ASAAC

The work being undertaken as part of the second phase of the ASAAC programme is focussing on making best use of commercial technology and is therefore hoping to ensure that elements that will be "standardised" are effectively already open standard solutions for which an avionic variant can be easily defined. The only drawbacks with the ASAAC solution are target platform and timescale. The target in the UK is the Future Offensive Airborne System (FOAS) and its in-service date is 2018. GKNWHL perceive the need to employ IMA in the nearer term and need to ensure that any solution adopted is not at variance with the developments in the ASAAC programme.

5.4. COMMERCIAL VME

Finally, VME and supporting commercial software is being given some impetus through two UK aircraft programmes, - both the RAF's Harrier GR7 and the RN's Harrier FRS2 are receiving mission system upgrades which will see the introduction of ruggedised VME and commercial operating systems. This is an interesting first step to an integrated modular system, enabling additional functions to be brought into the mission computer, but does not introduce other features of a modular system such as reconfiguration and a new packaging concept.

5.5. GKNWHL PROGRAMMES

GKNWHL have recently completed one and are involved in a second programme which focuses on the concept of Integrated Modular Avionics. The first programme, supported by a grant from the UK Department of Trade and Industry, was the PACTS-21 (Platform Applications for Commercial aircraft Transport Systems for the 21st Century) programme, involving collaboration with key UK aerospace companies including BAe Airbus, Smiths Industries Aerospace, Marconi Electronic Systems and Lucas Varsity Aerospace. The second is a UK Ministry of Defence supported programme called ReACH (Realisable modular Avionics Common across Helicopters) which is being conducted in collaboration with the Defence and Evaluation Research Agency (DERA) based at Farnborough together with Marconi Electronic Systems (MESL).

5.6. PACTS-21

The PACTS-21 programme had a civil aircraft focus, for which GKNWHL chose to examine the civil variant of the EH101, Heliliner. Through this work, GKNWHL examined a number of key issues and developed a simple commercial based modular rig. The key elements of study were:

- Asynchronous Transfer Mode,
- Future Avionic Architectures,
- the Systems Engineering process for complex systems and
- a Case Study to bring the elements together.

It has already been suggested that one of the problem areas for future modular systems is to adopt a data communication network that is an open standard solution and is long lived. Added to these the data communication network should also provide growth in terms of bandwidth and connectivity. Asynchronous Transfer Mode (ATM) is seen as a potential solution to the communication problem, providing a packet switching technique which has been devised to support a range of services including video, audio and data. GKNWHL have used ATM as the transfer mechanism between single board computers in their modular rig.

A packet switching network provides the opportunity to unify the network type within the avionic system, removing the need for separate backplane, data and video interconnects. The designer has the option of segmenting the system into different functional areas. Thus an ATM switch could provide circuit switch type operation (still using packets) in support of video data transfer and pure

packet switch operation within the core of the system, as shown in Figure 5. In the mission area, which was not studied in the PACTS-21 programme, mixing the high bandwidth segmented data with lower bandwidth messages is a possibility.

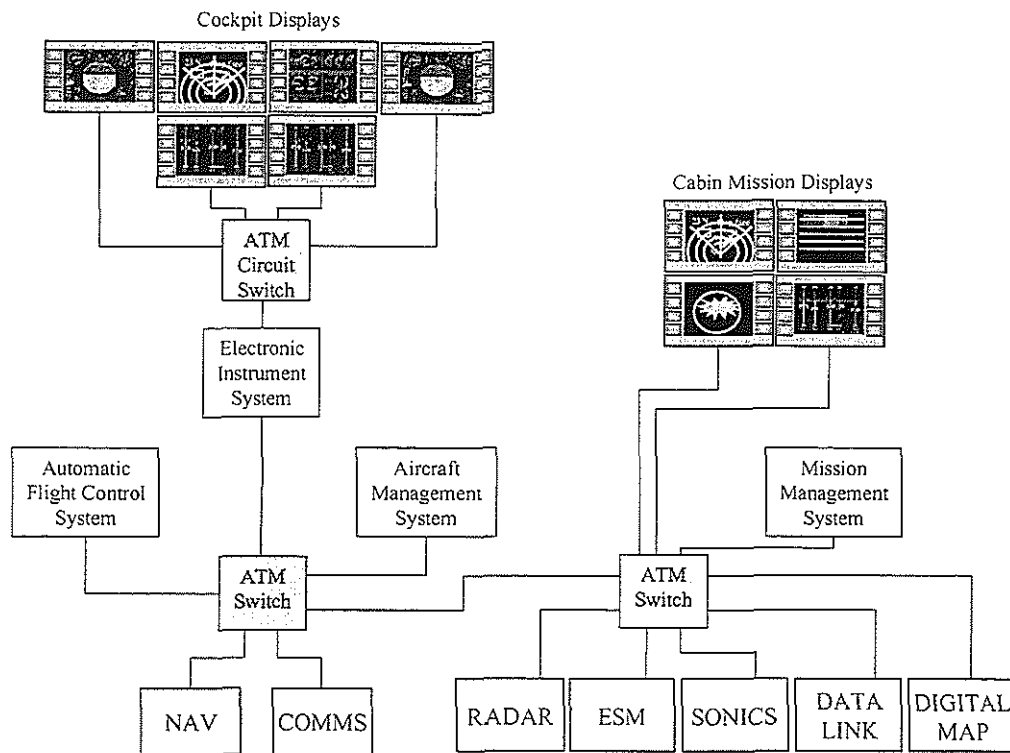

Figure 5 ATM Connected Architecture

ATM is not the only data communication systems option, alternatives are switched ethernet variants, Fibre Channel and Scalable Coherent Interconnect. It is likely that the first aerospace project to choose one of these networks will drive others to follow suit.

The PACTS-21 programme also enabled GKNWHL to examine the use of computer aided system engineering tools to support the systems engineering process in the development of complex systems. It is clear that if system designers are to succeed in their task with ever more integrated systems that good requirements management, function definition, design analysis and test/certification tools are necessary to manage the programme. GKNWHL were able to:

- capture and analyse requirements and link them into a functional definition using tools such as System Architect and RDD100.
- to analyse elements of the design using tools such as BONEs and Statemate and
- to implement the behaviour of a chosen function (the Communication-Navigation-Surveillance/Air Traffic Management described in ARINC 660A) in Statemate and use its autocode facility to produce an application onto the modular rig. An integrated software development environment, Rational Apex was used to support this process.

One of the important lessons learned from this exercise is that much work is needed to improve the flow of information through the set of tools that can support the systems engineering process for modular systems. This flow of information is important to record and trace design decisions and to support the certification process.

5.7. REACH

The ReACH programme has a military focus, taking Merlin HM Mk1 as the baseline helicopter and Merlin Mk2, Future Amphibious Support Helicopter (FASH) and Future Light Battlefield

Helicopter (FLBH) as the future target platforms. The main objective of the programme is to measure the worth of introducing IMA into these target platforms. The key stages of the programme are:

- Requirements and functional definition of the various platforms.
- Definition of *realisable* technology and architecture.
- Assessment of performance and costs of the system.

GKNWHL are responsible for the requirements and functional definition for which RDD100 is being used to manage the process. The tool is being used to capture the baseline requirements for Merlin HM Mk1 and then to record changes that are required in the form of additional, modified or removed functions.

Marconi Electronic Systems (MESL) have undertaken the technology and architecture scheme study which has identified technology that is realisable now or in the near term. The term realisable is specifically used as the aim is to understand what could be used in aircraft in the next few years and to understand how it will develop with time. One of the important goals is to ensure that the ideas developed in ReACH are not out of step with those of ASAAC. MESL's work in ReACH has involved defining the modules for a near term system and expanding upon their use within a processing group. This would for example, take the architectures shown in Figure 3 and Figure 5 to that of Figure 6 which shows a simplified form of the architecture with modular processing groups.

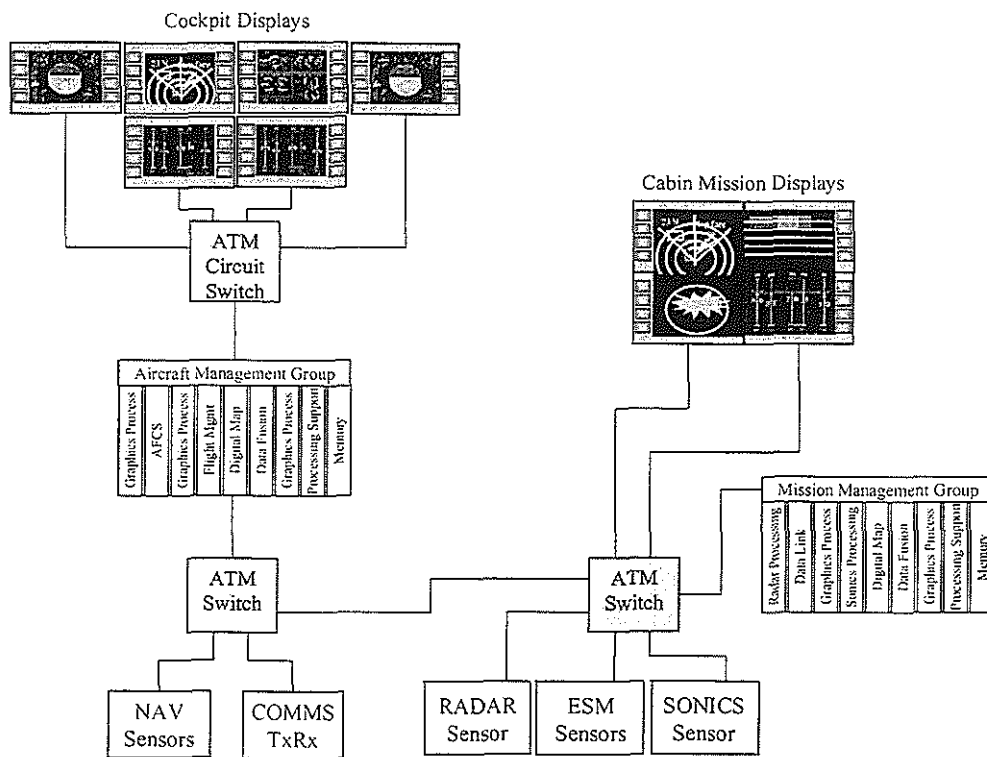

Figure 6 Architecture with Modular Processing Group

DERA and GKNWHL will take the functional definition and map the functions to the architecture scheme devised by MESL (not necessarily using ATM as the interconnect). The fully mapped architecture is then in a position to be analysed using tools available at DERA, in the form of performance models developed for SES Workbench, and at GKNWHL using Price H™ and S™ as well as Arena® to determine development and manufacturing costs as well as life cycle costs.

The architecture shown in **Figure 6** is not special to helicopters. The area that requires specific attention for helicopters is that of packaging of the new modular elements.

6. NEW PACKAGING CONCEPT

There has been much work on the various modular avionic programmes to devise methods to package and install the common modules, providing the necessary infrastructure to connect, remove heat and protect the module from the environment. The heat removal requirements of some module designs has led to the proposed use of liquid cooling via heat pipes. The modules also rely on edge ribs to remove the heat from the components and wedge locks to hold the module in place. Wedge locks are a hindrance to the removal of heat. By looking at the uses that the sides of module are put to GKNWHL have identified an alternative approach to packaging – the clamp stack approach.

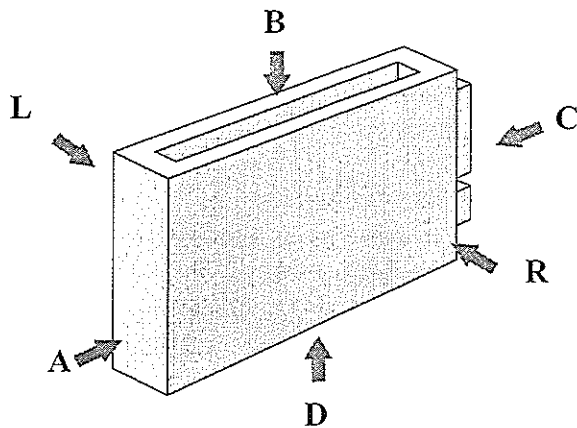

Figure 7 Module Side Names

Side **A** gives access for inserting and extracting the module to the rack.

Sides **B** and **D** provide access for the coolant.

Side **C** is taken up by the connectors.

This leaves sides **L** and **R** to be used for mounting.

The clamp stack modules are held in place by clamping forces applied at either end of the module set. The resulting arrangement frees the path for heat flow, removes heavy heat sinks and wedge locks and edge ribs and has a reduced parts count. The modules rely on float mounted connectors.

This module packaging arrangement has considerable advantages for helicopter systems as it is expected to be up to 50% lighter than conventional packaging designs.

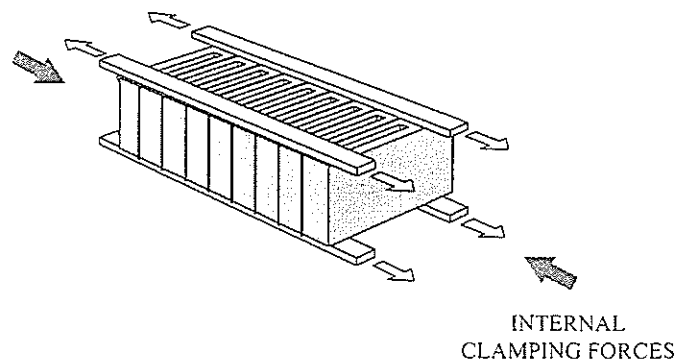

Figure 8 Clamp Stack Arrangement

7. RECONFIGURATION

It was suggested in Section 2 that with a modular system it is possible to introduce the concept of maintenance free operating periods (MFOP), that is the avionic system is able to tolerate faults and hardware failures for specified periods of time. These periods of time are designed to align with major maintenance activities of other aircraft systems. The MFOP is achieved by providing spare resources, common modules, within the avionic system that are available to a number of the avionic functions. This is in contrast to current practice where duplicate, complete line replaceable units (LRU) are provided one as a backup for another. In this case, the resources in the spare LRU are not available to other functions in other LRUs.

The technique of using spare, unassigned resources in a modular system is generally termed reconfiguration, see **Figure 9**. Two distinct forms of reconfiguration can be considered, static and

dynamic. Dynamic reconfiguration is designed to occur during avionic system operation in flight while static is targeted at recovering the functional capability of the aircraft on the ground.

Developments in the performance of built-in-test systems, enabling accurate fault detection, identification, location and isolation are vital. Work at GKNWHL has involved identifying techniques that can be applied at the various layers of the system framework, at the application, the operating system, drivers and hardware.

Some of the built-in test techniques identified included:

- syndrome pattern matching; the use of diagnostic look-up tables derived from failure mode and effect analyses, modified to include environmental information from temperature and stress monitoring devices and operational experience.
- boundary scan testing; a well established technique for testing digital circuitry which relies on the components embodying boundary scan facilities.
- n-version programming; where multiple variant versions of a software application are used to detect the failure of a software function by the comparison of the outputs of the different versions.

The application of reconfiguration, particularly in its dynamic form is considered high risk, and will probably be limited initially to non safety critical systems, specifically in the mission system. The action of reconfiguration must be pre-defined at the design stage in order that the appropriate test and validation of the effect can be fully determined.

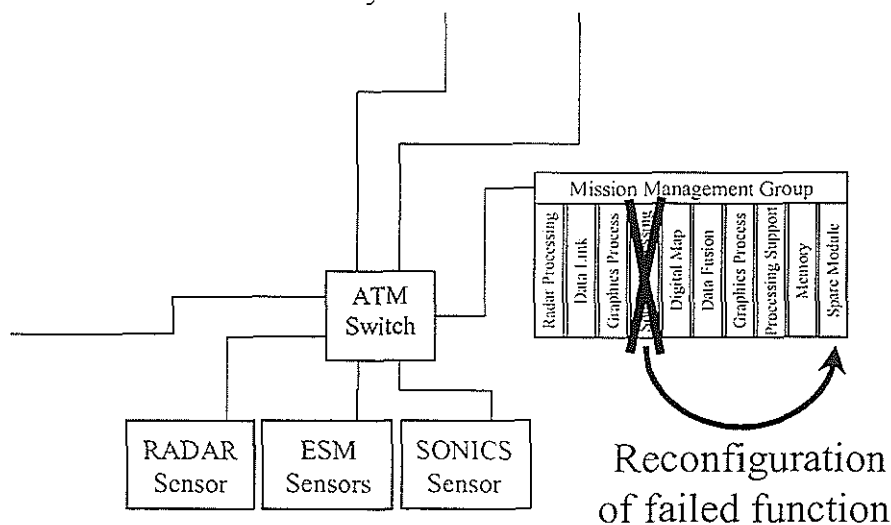

Figure 9 Reconfiguration of a Processing Group

8. EXTENDING THE DIGITAL DOMAIN

There is an opportunity with the introduction of modular avionics to extend the digital domain to all parts of the aircraft. The modular approach seeks to bring processing functions to the centre of the system enabling resources to be shared effectively between these functions and take advantage of spare modules to support the reconfiguration strategy. On the other hand, the placement of a particular modular component away from the centre of the system is designed primarily to reduce weight, but also improve system reliability. This component is termed a remote data concentrator (RDC) and has a number of specific uses. As its name suggests, it provides a means to gather up sensor data, normally of a low bandwidth, in a remote part of the aircraft and transmit it in digital form over a data network to the central processing resource. The RDC can also contain functionality which can provide local control of a system element and thus becomes a "smart" RDC.

Work by Lucas Varity within the PACTS-21 programme was particularly concerned with the use of smart RDCs in fly-by-wire actuator control architectures. Lucas focused upon the use of a generic smart actuator controller which was designed to be fitted to the secondary actuators of a fixed wing aircraft offering a light weight, low cost solution to the control of these systems.

GKNWHL's work on the use of RDCs in helicopters has not shown their use to be beneficial for sweeping up low bandwidth sensor signals. This is partly because there are actually few remote locations on a helicopter and the weight of an RDC is currently expected to be greater than the amount of wiring it is likely to replace. GKNWHL are likely to retain low bandwidth sensor interfacing within a modular rack. Efforts to reduce the number of types of analogue and discrete signal through standardisation may make the use of RDCs in helicopters more attractive.

9. QUALIFICATION AND CERTIFICATION

The topics of qualification and certification are important issues to be addressed when proposing a change in avionic system design from a federated avionic system, characterised by strict functional and physical partitioning to an IMA system with complex integration. The expectation that an IMA system can simply be implemented with common hardware and software from different vendors is obviously a naïve one. It is important to consider the route to qualification and certification from the outset of the design process, making use of computer aided system engineering tools to manage the process and show traceability of requirements and design decisions to the tested article and providing support for safety analysis.

There is a change in philosophy required to certificate future IMA systems. It is unlikely that the current safety analysis techniques associated with federated systems will be appropriate to IMA technology in particular when the issue of commonality raises the probability of common mode failure. It follows that a significant advance in the certification process is required to enable the exploitation of this technology. The term "incremental certification" is being associated with the process by which certification may be achieved for highly-complex systems. This will allow elements of an IMA system to be certified in isolation, for example the hardware and application software would be certified as independent components. This approach aims to limit the cost of re-testing a complete system that has been modified, for example with the introduction of a new processor to replace an obsolete one or a new avionic function. Any enhancements to the certification process will need to address the following issues:

- Software portability; application and operating systems,
- Software partitioning; integrity of multiple applications (e.g. navigation, communication) being performed on the same processing module,
- Configuration control; the run-time allocation of functions to available resources,
- Mixing of applications with mixed criticality.

The Society of Automotive Engineers has produced aerospace recommended practice, ARP4754, titled Certification Considerations for Highly Integrated or Complex Aircraft Systems which discusses the subject from a total life cycle aspect.

10. CONCLUSIONS

This paper has addressed a wide range of topics concerned with modular avionic systems and what is particularly important for its introduction in helicopters. Obviously, the fundamental principles behind IMA for helicopters does not vary from that of fixed wing aircraft, either military fast jet or civil airliner. However, the helicopter is renowned for its flexibility and presents particular challenges for IMA if this flexibility is to be fully exploited. GKNWHL are continuing to develop their understanding of IMA principles in collaboration with other UK companies and research organisations and are also looking forward to working with Agusta and other European companies on the forthcoming Framework 5 programme, PAMELA.