

SIXTH EUROPEAN ROTORCRAFT AND POWER LIFT AIRCRAFT FORUM

Paper No. 67

INTEGRATED MULTIPLEX
FOR THE
AGUSTA A-129 ATTACK HELICOPTER

J. I. OHLHABER

Senior Systems Engineer, Advanced Systems Staff
Harris Government Information Systems Division
Melbourne, Florida USA

September 16-19, 1980

Bristol, England

THE UNIVERSITY, BRISTOL, BS8 1HR, ENGLAND

ABSTRACT

The author has led design teams investigating electronic system integration for several aircraft and helicopters. This paper presents the results of the most recent and most extensive integration study for the Agusta A-129 helicopter and the work planned toward reducing this to practice as a result of a development contract award from Agusta to Harris Corporation for the system development and initial production. The system will utilize a MIL-STD-1553B data bus system, multimode cockpit displays, digital flight control with backup fly-by-wire, and armament management; all controlled through a central processor system.

INTEGRATED MULTIPLEX FOR THE AGUSTA A-129
ATTACK HELICOPTER

By: Jack I. Ohlhaber, Senior Systems Engineer
Advanced Systems Staff
Harris Corporation, Melbourne Florida, USA

1.0 Introduction

A new generation in electronic system integration has begun with the A-129 Italian Light Attack Helicopter being designed and built by Construzioni Aeronautiche Giovanni Agusta. Although many advances are planned in the A-129, the major step in this author's view has been the commitment, by Agusta, to fully integrate the electrical and electronic subsystems to improve performance, survivability and supportability. This step will make practical use of the most modern technology available including high intensity CRTs, special symbology generators, redundant MIL-STD-1553B data bus and digital data processing to consolidate and interchange data among all systems. The system which accomplishes this is called the Integrated Multiplex System (IMS) and is being designed and initially manufactured by the Harris Corporation, Government Information Systems Division under contract to Agusta.

The system integration effort of this Agusta/Harris program is focused in four major areas; all of which have been simplified and are able to cross-communicate with one another:

- Mission Electronics - Optimized interconnection of all mission equipment including radios, navigation equipment, and weapons management which provide for change and growth as well as efficiency.
- Utility Systems - Handling of electrical power distribution, power plant monitoring and control caution and warning and integration of other general airframe related electronics. This provides workload reduction and wiring efficiency.
- Flight Control and Stability - Including motion sensors, digital stability augmentation system, and Flight Director functions.
- Cockpit Control and Display - Including integrated Flight Management, radio control, instrumentation and workload reducing automation.

All of the above, as well as other electrical and electronic areas will be integrated together using redundant MIL-STD-1553B data bus communication and centralized data processing.

These integration measures are expected to increase pilot effectiveness by giving him better controls and displays with more usable information and increase aircraft performance, survivability and reliability. In addition, the flexibility of the aircraft to meet new missions and use new or different generations of avionic and mission equipment is dramatically enhanced. Because of this integration, there will also be large savings in life cycle cost and hopefully in initial production cost as well.

This paper will address the specific design approached used to form the baseline system and program plans and progress toward accomplishment of this integration.

2.0 The A-129 Aircraft

The A-129 aircraft will serve multimission roles. As indicated pictorially in Figure 1, several variations of Attack and Scout missions are projected for the future. Presently, the Harris IMS design centers around the Attack configuration; however, the inherent flexibility of the system makes even broader applications practical.

Table 1 summarizes principal aircraft features for prime mission configurations.

3.0 Integration Approach Taken

Successful aircraft integration can be simply stated as tying all mission and avionic equipment together so that it can operate most "efficiently" and so that unnecessary or overlapping hardware and functions can be eliminated.

However, the requirements implied by the word "efficiently" are enormous. Some implications are: simpler interface with crew, safer, more survivable, lighter, more reliable, easier to maintain, high accuracy, easily expanded or reduced, simple to change or modify, usable with a wide variety of avionic and mission equipment "sensors", new, old, and future, and of course lower in cost.

I have been intimately involved in the search for a solution which meets these requirements for over 17 years, and am here to report that there are a lot of approaches that do not work. But the good news is that there is at least one that does. This approach is based on a set of system architecture rules that demand complete flexibility in servicing past, present or future

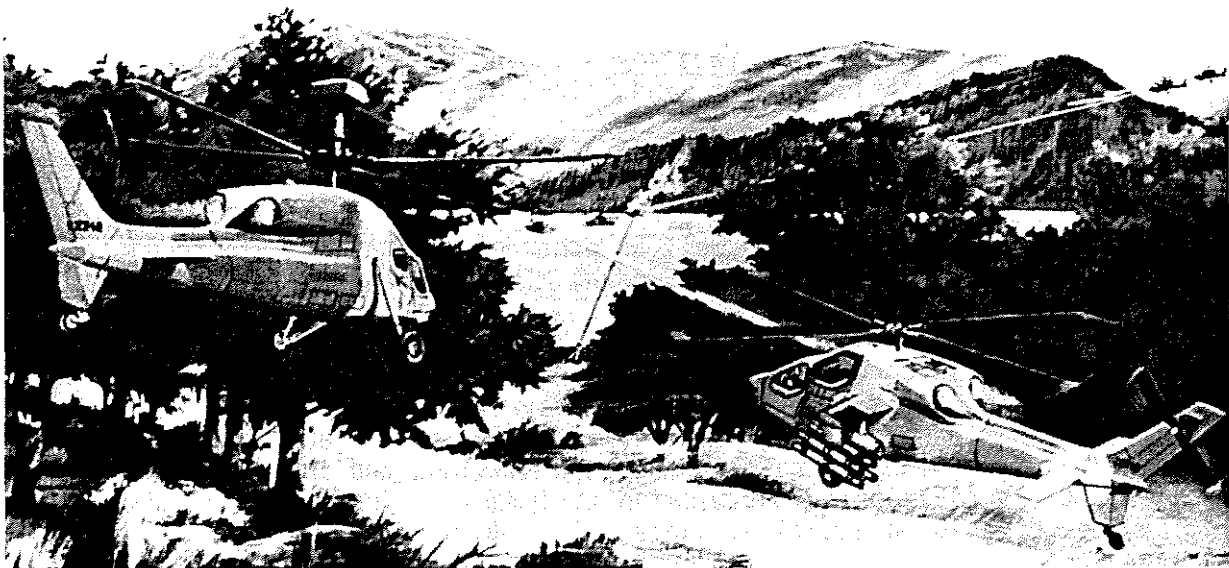

Figure 1. A-129 Multimission Aircraft

Table 1. A-129 General Characteristics

Single rotor, 4 blade (fiberglass) articulated

Crew of two, tandem seating

Armament: 8 tow missiles or 52 rockets (or combination) w/options for machine gun pods and external fuel tanks. 4 armament/stores stations on stub wings.

Mission gross weight with tow missiles - 8000 lbs (3665 KG)

Max level flight speed - 143 kts (263 kph)

Range - internal fuel - 283 nm (525 km); external fuel - 450 nm (830 km)

Endurance - internal fuel - 3.0 hrs.

Electronics - full electrical/electronics integration including flight controls and displays using redundant MIL-STD-1533B central processing and fault detection.

Navigation - digital automatic, 3 dimensional Kalman filter combined: air data, rate gyro, Doppler, radar altimeter, inertial reference growth provisions to Omni, Tacan, MLS.

Flight control - primary single mechanical, dual digital electrical fly-by-wire backup.

avionics and mission equipment. The major point in the efficiency of this architecture is that it requires very little industry standardization. This seems counter to popular military and national policies but is an essential fact if the system is to be useful for a new generation of equipment, aircraft and missions which have not been created yet. If followed, these rules will guarantee good efficiency (possibly 80%) in most applications.

It is absolutely true that standardization is necessary within a given system for common functions and it is desirable to have standardization between many different aircraft to gain any of the remaining 20% in efficiency. Useful areas to apply common standards include: data buses, interfaces, circuit cards, power supplies, housings, software languages, modular software approach, and CPU architectures. However, we can never forget that a flexible architecture is the prime objective, and it is necessary that the standardization be done in such a way that it can be easily changed to accommodate inevitable advances. For instance:

- It should be possible to remove plug-in data bus modules to convert from MIL-STD-1553B to a higher speed optical data bus which is inevitable.
- It should be possible to interface existing radios of almost any type to the chosen data bus.
- It should be possible to remove present microprocessors and replace these with faster or more efficient units.

Building this kind of flexibility into the architecture may appear inefficient but in fact it guarantees that the best, most efficient hardware

can be used over the 20 to 30 year life of the airframe without being burdened with an obsolete "standard" interface.

4.0 Architecture Rules Used

A complete discussion of these architecture rules is beyond the scope of this paper but in summary they are listed below and indicated in Figure 2.

- (1) Choose sensors (radios, transmitter/receivers, Doppler navigation TR's, inertial sensors, electronic power controllers, cockpit switches, displays, proximity sensors, etc.) to suit the application and cost.
- (2) Interface or adapt all sensors to a common data bus with sufficient speed to handle all data (such as MIL-STD-1553B).
 - (2a) Make the data bus at least dual redundant depending on a vulnerability analysis and spacially separate.
- (3) Perform all logic, processing, navigation, threshold, flight control functions in a central IMS computer where possible.
 - (3a) Make the entire system computer at least dual redundant depending on a vulnerability analysis and spacially separate.
- (4) Functionally modularize all software in a top-down structured program so that modules may be altered without affecting other sections. This requires additional memory but the flexibility is essential.
- (5) For the present, video generation should be integrated as best as possible with symbol generators. Data for symbol generation should come from system computers.
- (6) Packaging enclosures for adapter and processor circuitry are decided based primarily on physical location and survivability requirements for the unit functions.
- (7) Additional redundancy for sensors is provided based on vulnerability analysis by accessing adapter circuits in other system units from critical sensors.

A more comprehensive treatment of this process emphasizing steps toward optimization may be found in paper by Mr. Dave Kanaly (Ref. 1).

5.0 Systems Proven

This general approach was begun in 1969 and based on a multiplex system using a 1 Mb/s Manchester coded data bus which was the basis for the present MIL-STD-1553B. This system was used by the author on the fully Integrated Multiplex System for the B-1 aircraft by Harris. The Harris Electrical Multiplex system as it is known was designed into the original aircraft and each prototype aircraft. The system has accumulated over 2,500 flight hours and has proved totally successful in meeting these requirements.

Later applications of this same architecture were used to a limited extent in the US Navy McDonnell F-18, USAF General Dynamics F-16, U. S. Army AH-64A Attack Helicopter by Hughes and the U. S. Coast Guard Short Range Recovery Helicopter by Aerospatiale.

ARCHITECTURAL APPROACH

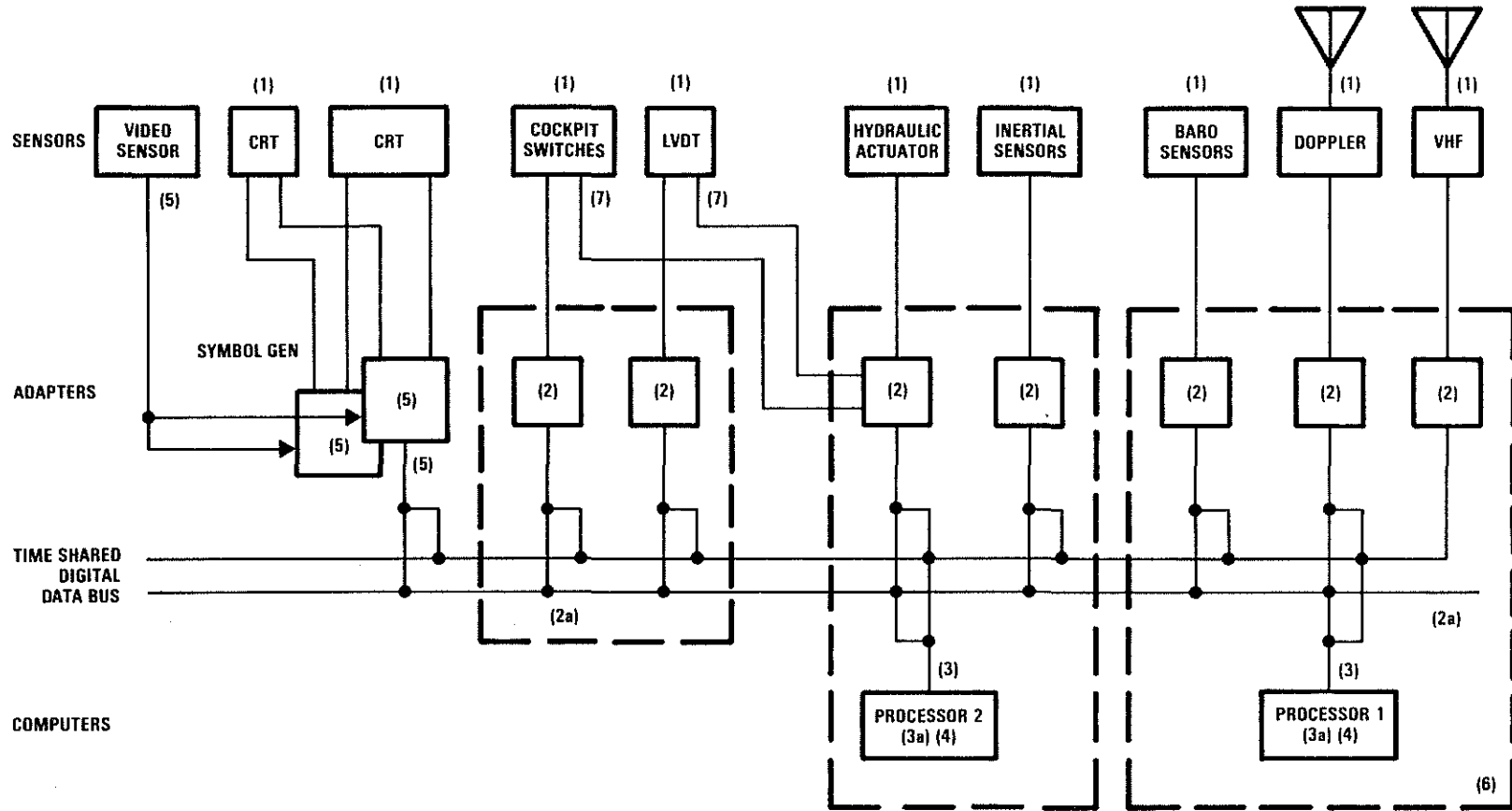

Figure 2.

In general, use of Integrated Multiplex techniques has been quite limited. This is at least partly because the advantages offered by full system integration are far more useful and attractive when applied broadly to a new aircraft design where full advantage can be taken in cockpit design, reduced mission avionics, reduced wiring and simpler installation and checkout requirements. The A-129 is just such a design opportunity.

6.0 A-129 IMS Program Baseline

The integration approach discussed above was applied to the A-129 by Harris Corporation in one of the broadest and most comprehensive integration studies undertaken to date. This study was awarded by Agusta to Harris in February of 1979 and established the IMS baseline for the A-129. The effort culminated in a competitive award to Harris Corporation in July 1980 for development, initial production and production options for the IMS.

The baseline configuration for the A-129 integrates a wide variety of functions as indicated in Table 2. Some key items are discussed below.

Table 2. Typical Functions Served

- | | |
|--|---|
| ● Integrated Helmet Display and Sight System | ● Automatic Data Links |
| ● Pilot Night Vision/FLIR | ● Provision for Jammers |
| ● Aircraft Performance Monitor | ● Armament Management |
| ● Multimode Primary Flight Displays | ● Target Acquisition System Interface and Computation |
| ● Three (3) Dimensional Automatic Navigation | ● Stability and Navigation |
| ● Four (4) Axis Autopilot | ● Survivability Equipment Control |
| ● Backup Fly-By-Wire | ● Radio Communications Control and Display |
| ● Fuel Management | ● Electrical Power Switching and Management |
| ● Engine Instrumentation | ● Caution and Warning Collection and Display |
| ● Intercommunication | |

The aircraft performance monitor pulls together data on actual engine performance, air temperature and pressure, fuel load weapons remaining as well as aircraft fault and damage assessment to make an accurate calculation of aircraft ability to hover in ground effect, clear obstacles at selected distance, climb, etc. These can be selected for display on the CRT.

The navigation aids are coupled to the flight director and include Doppler, simple air data, radar altimeter, orthogonal accelerometers and vertical and directional gyros. Other aids which can be coupled include omni, TACAN, global positioning system, microwave landing system and a positive ground radar control link.

The 4 axis digital autopilot and three dimensional flight director and flight director - coupled systems allow many control options including:

- Manual flight
- Stabilized manual flight with attitude and course retention
- Automatic climb and flight to one of ten selected flight plans or segments
- Automatic hover hold

Redundant, backup fly-by-wire is provided. A mechanical linkage operates normally in addition to IMS stability augmentation. In the event of a mechanical malfunction, either of two separate (redundant) IMS wire control paths will couple the crew controls to the hydraulic boost actuator. Most of the remaining functions are self-explanatory.

The resulting system configuration is shown in Figure 3 and major IMS units are shown pictorially in Figure 4. The most recent cockpit arrangement for the front panels is shown in Figures 5 and 6. The intention is to display essential information on the CRT as close to the windshield as possible to reduce possible disorientation when referring to the displayed data. As noted in Figure 3, the CRT displays are driven from separate symbol generation units.

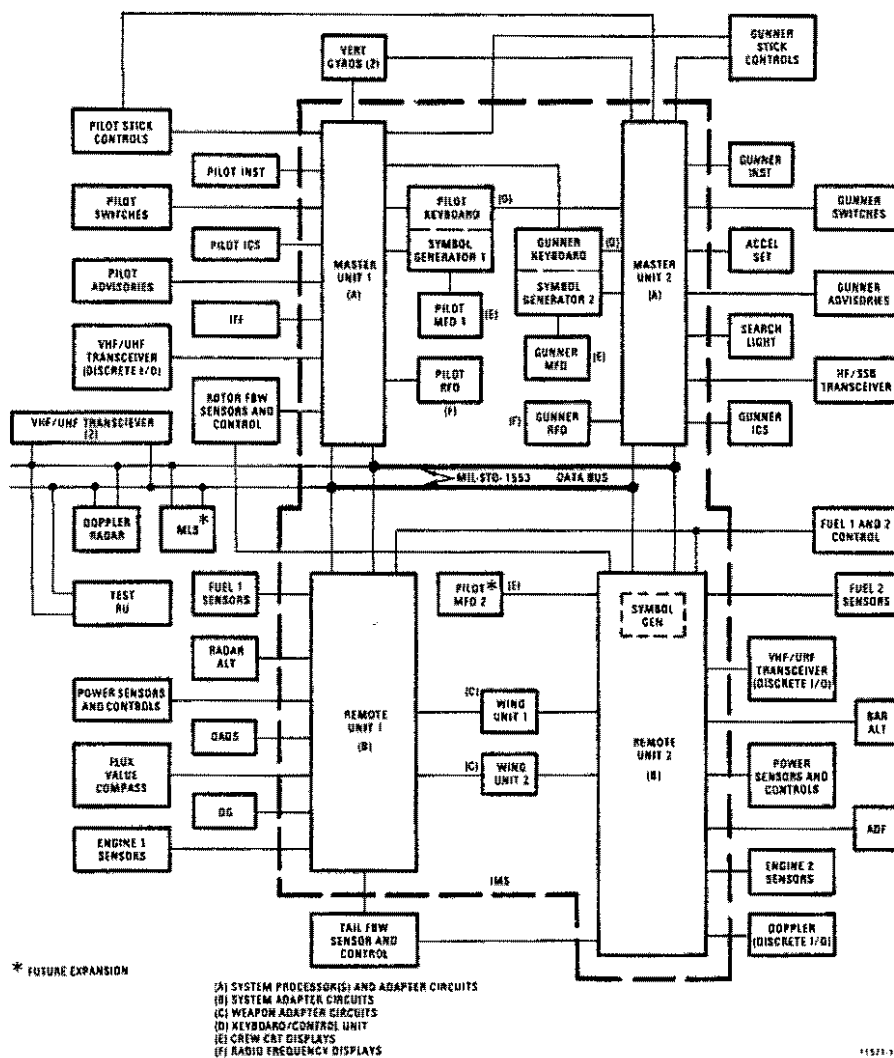

Figure 3. IMS System Configuration

IMS PICTORIAL

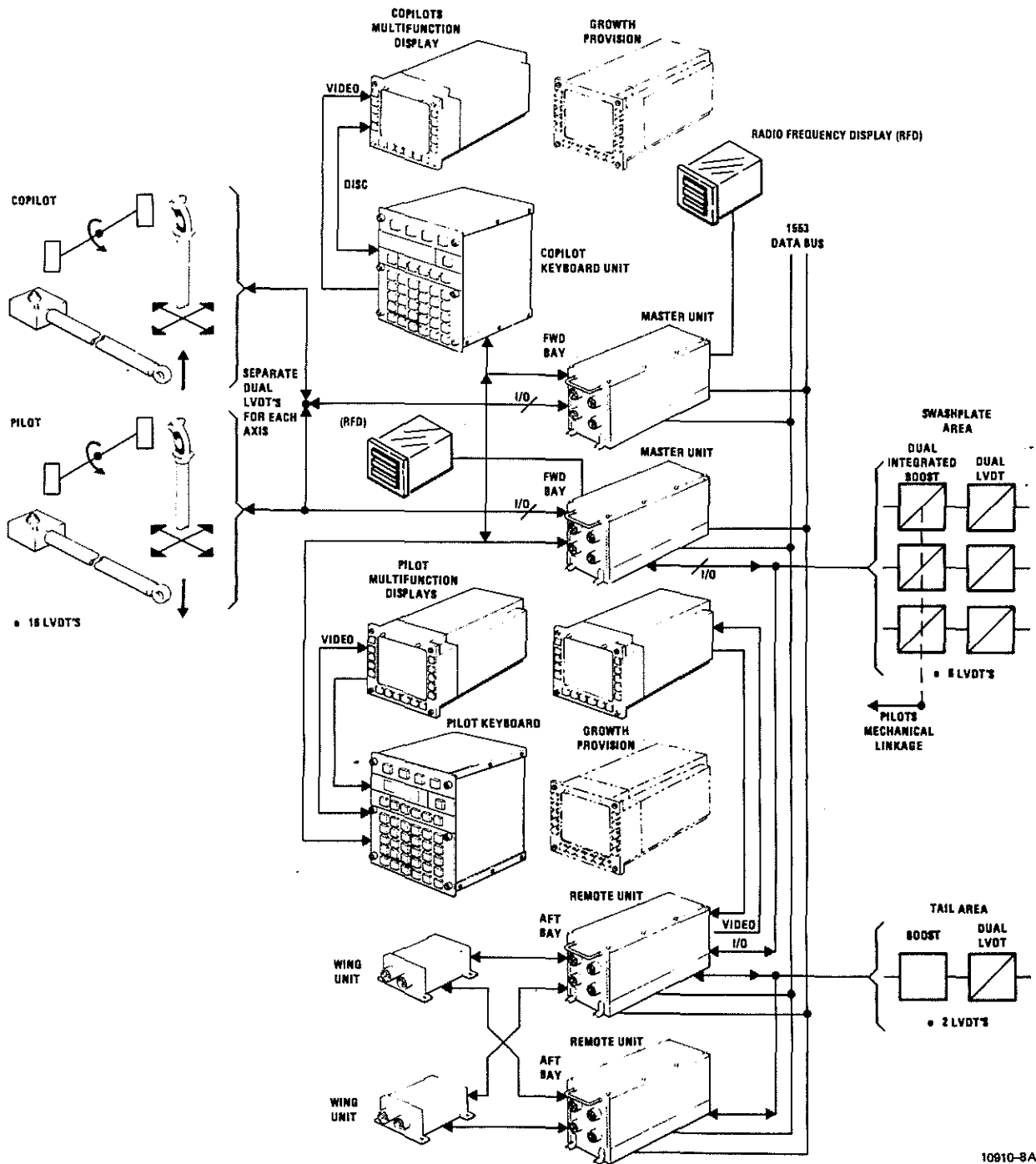

Figure 4.

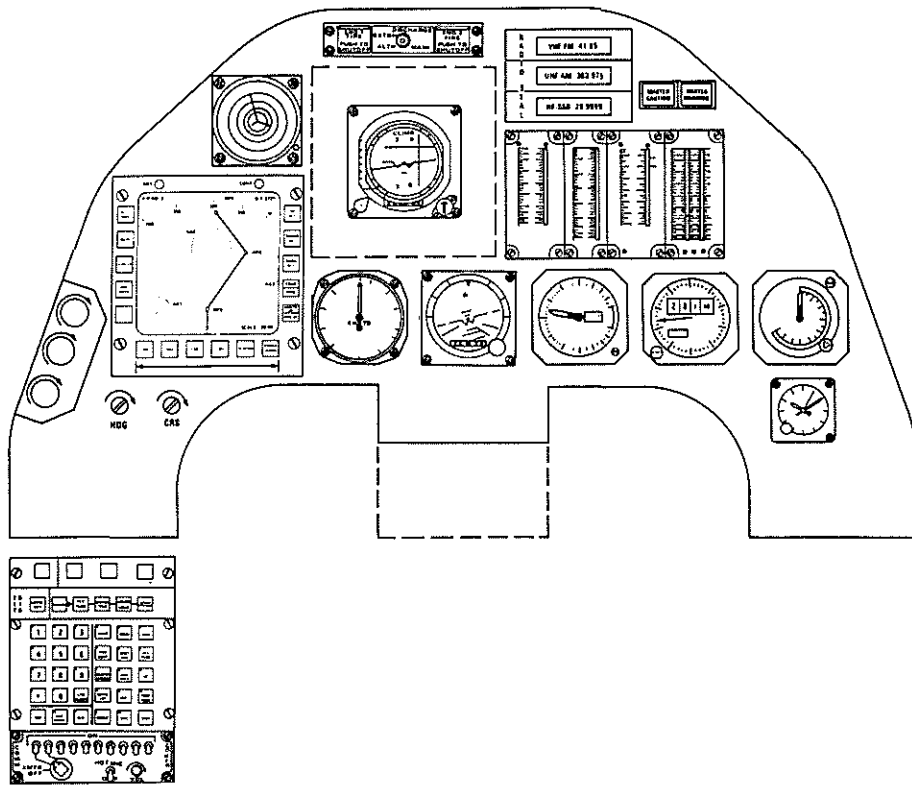

Figure 5. Integrated Pilot's Cockpit Panel

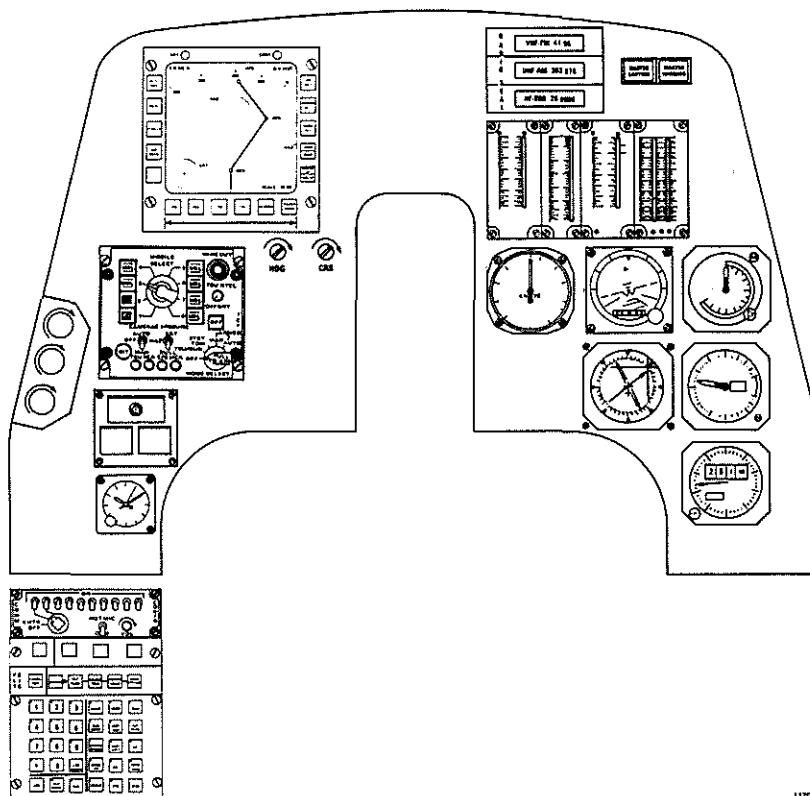

Figure 6. Typical Observer/Attack Gunner Panel

7.0 Program Plan and Status

Figure 7 shows the general program plan for the A-129, IMS development phase. Key points of this program are:

- The baseline development is based on over a year and a half of study.
- The hardware design (line 4) has already begun and produced master and remote units and a test display unit brassboard. Housing designs and brassboard circuit cards are shown in Figures 8 and 9.
- The Zilog Z8000 CPU's have been completed in brassboard card form (upper center Figure 9) and basic operating software has been completed.

The brassboard hardware will be used in preliminary A-109 flight test and then fully developed for the A-129 configuration as shown (line 4).

Work is underway now to prepare digital flight control algorithms (line 2). These will be simulated and then flown on a aerodynamically similar A-109 beginning in the 11th month of the program to prove the basic design and optimize the algorithms.

Flight control software will be included as one of many operational modules for each functional operation noted in Table 2.

Summary

The Harris Corporation and Agusta have embarked on a program to fully integrate the A-129 Helicopter electrical and electronic system as well as cockpit instrumentation. The development is based on over a year and a half of joint work and analysis and is moving quickly to an initial flight test in the A-109 and then to full A-129 flight test at 30 months. We believe this is a major design and technology improvement toward a better aircraft for both the suppliers and users. Some ultimate characteristics are projected in Table 3.

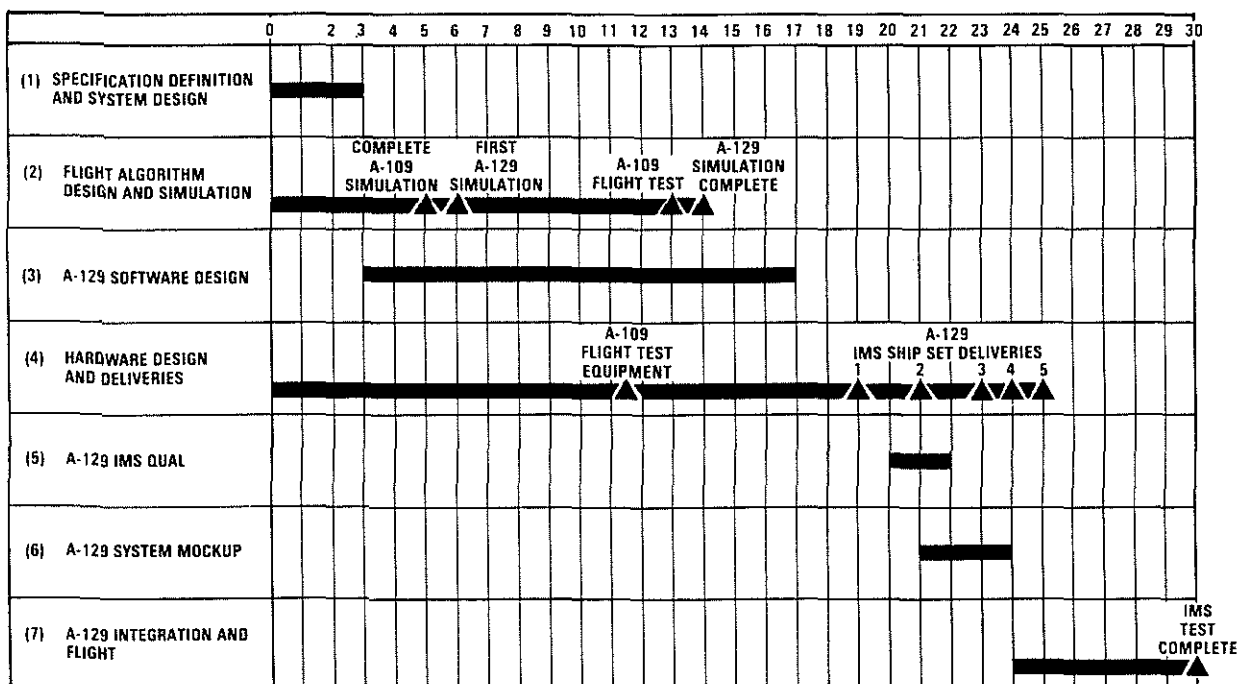

11703-4

Figure 7. Schedule

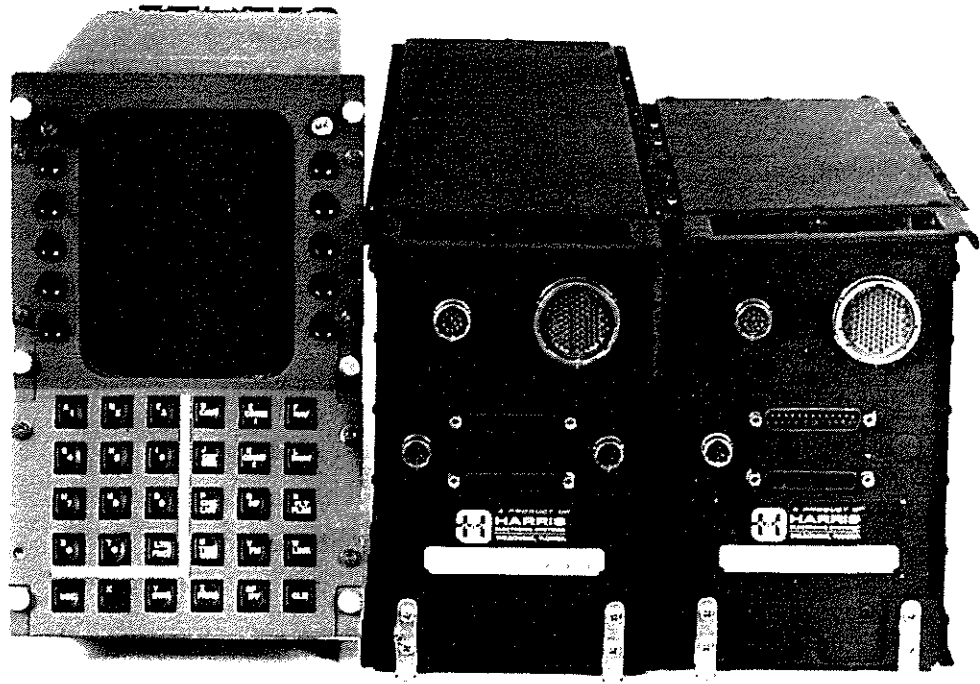

79-4899-2-1

Figure 8.

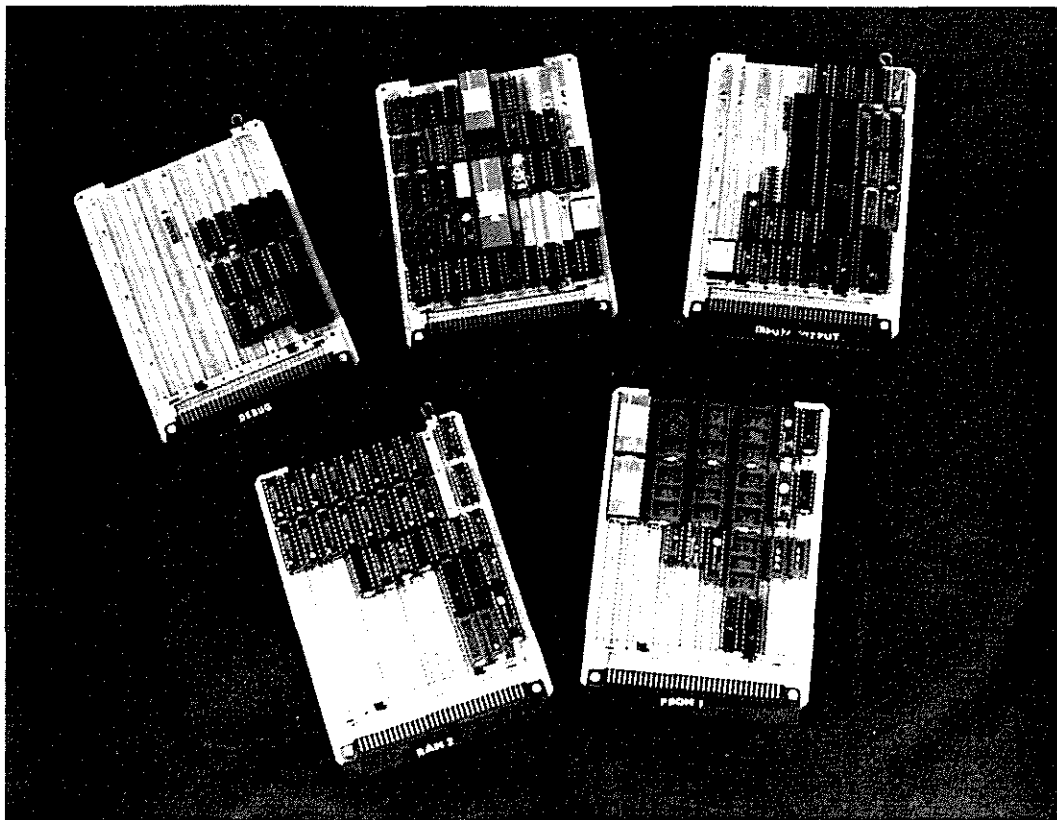

79-4691C

Figure 9. Minimum System Card Set

Table 3. Projected IMS Application Results

Parameter	New Attack or Scout Aircraft
● Integrated Multiplex System Equipment Weight	133 lbs. (60.5 kg)
● New Weight Saving to the aircraft over a conventional configuration	120 lbs. (54.5 kg)
● Improvement in Battle Survivability	over 3:1
● Mission Reliability (between mission alerts)	660 hours
● Piece Part Reliability	200 hours
● Reliability Improvement Factors	5:1
● Memory Required	62K words
● Modular Memory Utilization	48 percent
● Processor Utilization	360 kop (40%)
● Data Bus Utilization (MIL-STD-1553 B)	45 percent
● Pilot workload reduction (estimate)	4:1

REFERENCES

1. "Achieving the Full Benefits of Integrated Multiplex in the 1980's" by D. B. Kanaly, Harris Corporation; 36th Annual Forum of the American Helicopter Society, Washington, D.C. - May 1980. Print # 8015