

REFERENCE : EP04

**TITLE : HELICOPTER GEARBOXES : NEW REQUIREMENTS, NEW TECHNIQUES**

AUTHORS :

Pierre MARET - "Mechanical Competence Centre" - EUROCOPTER

**SUMMARY**

Over the last fifteen years, the requirements regarding technical performance, reliability, safety and maintenance costs have evolved considerably. In view of the economic constraints associated with the competitiveness of the market, the technologies employed for the older generation helicopters are no longer adequate to satisfy the latest performance requirements.

This paper presents on the one hand the approach adopted by Eurocopter and the new technologies employed in the production of modern gearboxes, and on the other hand describes the demonstrations and the results achieved with recent gearboxes (Tiger, Colibri, EC 135) during endurance testing, operation following loss of oil and the improvements achieved in terms of simplified maintenance.

**1. NEW REQUIREMENTS**

The gearbox is the indispensable link used to transmit the power from the engines to the rotors. It is one of the heaviest components on the helicopter, both in terms of weight and in terms of development, production and maintenance costs.

In addition to the economic constraints associated with the competitiveness of the market, which call for reduced development lead times and production costs, comes the need to satisfy the ever more demanding regulatory requirements, increased performance levels and reduced operating costs.

• **Regulatory requirements**

The regulations and procedures, which take into account the millions of flight hours flown, are constantly changing in order to increase the level of safety and achieve the  $10^{-9}$  target as the rate of occurrence of a catastrophic accident per flight hour.

In the particular field of gearboxes, among the most significant regulation changes over the last 10 years, comes the FAR 29 CAT. A (FAR 29.927 c amdt. 26) requirement to be able to operate for 30 minutes and then land following loss of lubricating oil, the damage tolerance requirements (FAR 29.571 amdt. 28) and more

recently, the introduction of fault analysis in the context of "design assessment" (FAR 29.917 amdt. 40).

• **Increased performance levels in terms of weight and reliability**

The increase in operational capacity of helicopters demands savings in weight for a given transmitted power, and enhanced reliability : reduced removal rates, monitoring and fault detection systems...

• **Direct operating and maintenance costs (DMC and DOC)**

Analysis of helicopter operating costs shows that the Main Gearbox (MGB) is one of the most costly items.

For this reason, one of the major objectives on the MGB is to increase the reliability over an extended operating period : increased time between overhauls (TBO), "On Condition" monitoring.

The cost reduction also involves simplifying the maintenance and therefore the gearbox components.

Although the 43 million flight hours accumulated over almost 50 years represent a considerable pool of experience for the new gearbox

designs, the techniques employed for the older generation helicopters are no longer able to satisfy these requirements.

This has led EUROCOPTER over the last fifteen years to develop and refine new techniques which hinge around three aspects :

- design optimisation,
- materials and processes,
- monitoring and fault detection means.

## 2. NEW TECHNIQUES

### 2.1 Design optimisation

This optimisation is based on heavy use of simulation and calculation of the gearboxes covering various fields such as :

- geometric modelling : digital 3D modelling under CATIA V4 of the gears, shafts, casings in order to optimise the overall process from computer aided design, through geometric modelling for simulation and calculation applications, to programming and machining.

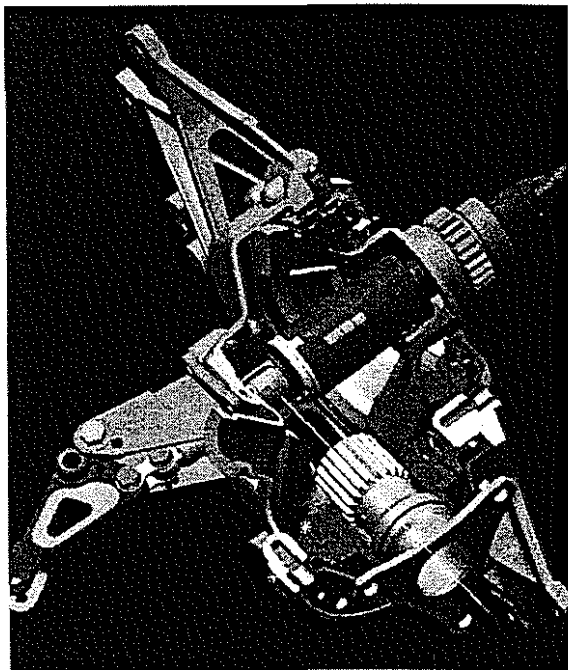

Figure 1 : Tail Gearbox

- MGB behaviour under load : in order to achieve perfect design of casings for optimum loading of bearings and gears under all helicopter flight conditions and main rotor bending moments.

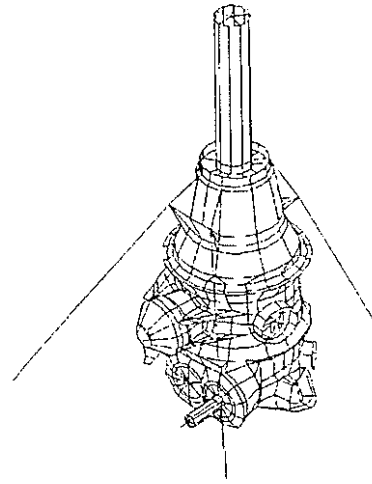

Figure 2 : MGB model for simulation of behaviour under load

- gears : simulation and optimisation of running patterns under load, taking into account deformation of casings, web elasticity and geometric defects, for both spiral bevel and spur gears.

Additionally, these tools enable the setting parameters to be determined for the gear tooth grinding, therefore ensuring faithful and rigorous production of the tooth flanks defined by simulation.

Figure 3 shows computer simulated pressures exerted on spiral bevel gears, before and after algorithmic simulation, and the result achieved during testing of the actual gear pattern : this shows the very good performance of current gear design optimisation software.

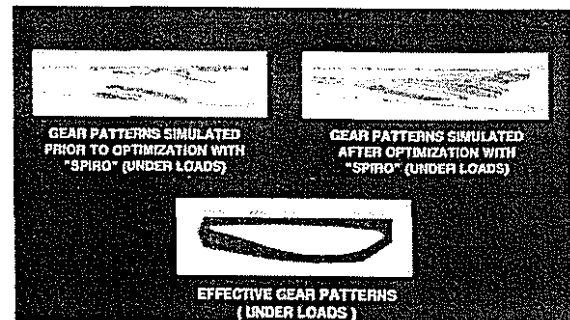

Figure 3 : Gear pattern design optimisation/ test results

- bearings : study of the load and pressure distributions on rolling elements taking into account the deformations of the casings and shafts, the assembly conditions and the

temperature gradients in order to optimise the internal geometry with respect to the operating conditions.

- thermal and oil cooling modelling : oil cooling is fundamental to gearbox reliability, and thermal cartography is employed in the design process for determining oil flows and positioning the oil jets, as well as to evaluate thermal deviations.  
Figure 4

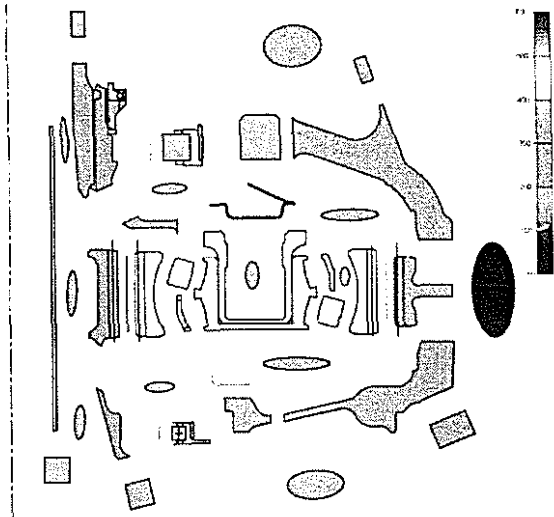

Figure 4 : Thermal imaging of an epicyclic gear

Other than the modelling aspect, optimisation also involves the study of architectures, designs and new assembly methods, integrating several functions into the same component in order to keep the gearbox as simple as possible and to eliminate problems encountered in operational service of the fleet.

The most typical examples for gears are the elimination of bolted assemblies which are a source of fretting corrosion which can result in fatigue cracks, and the use of electron beam welding. Another example is the use of bearing races machined directly on the gear, thus eliminating any potential problems of fretting and creeping of the races, whilst at the same time reducing the number of parts and saving weight.

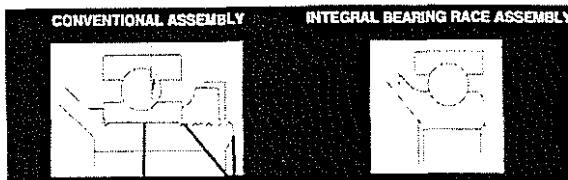

Figure 5 : Comparison between a conventional bearing assembly and one with an integral bearing

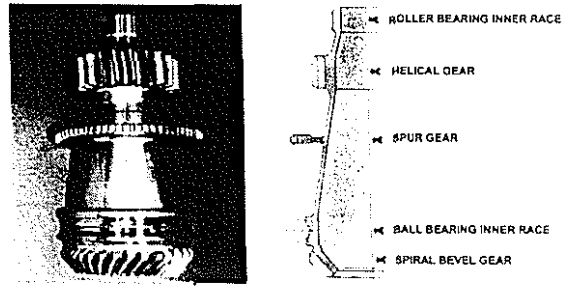

Figure 6 : Extensive integration : Tiger MGB Tail take-off pinion

This type of assembly naturally requires a material and heat treatment suitable for the integration of the different functions.

## 2.2 Materials and processes

The most significant advances made concern the "Deep Nitriding" technology for gears and bearings, and the introduction of the new WE43 magnesium alloy combined with an improved type of anodising (HAE process) for casings.

- Nitrided gears and bearing races :  
Over the last 20 years, 32CDV13 steel gears nitrided to a shallow depth (0.3 to 0.4 mm) offered a good cost/performance compromise for gears. The development of a "deeper" nitriding process proved that this technology could also be highly effective for roller and ball bearing races. Using these capabilities and properties, it has now become possible to design and manufacture industrially, complex shaped gears with teeth and bearing tracks connected by thin wall webs, as in the Tiger MGB tail take-off pinion (fig. 6).
- WE43 magnesium alloy casings :  
EUROCOPTER have attempted to improve corrosion resistance through the use of more efficient protections, new alloys which are less sensitive to corrosion and more damage tolerant. This has led to the selection of the new WE43 magnesium alloy, and the adoption of a new type of anodising protection (HAE) sealed with varnish. Results are very good in the highly corrosive salt spray atmospheres specified by the severe test standards applicable to naval helicopters. The results achieved with WE43 Mg alloy have exceeded even those possible with A357 aluminium alloy.

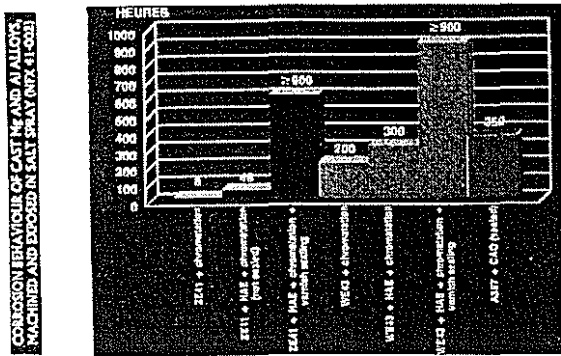

Figure 7 : Corrosion behaviour of cast Mg and Al alloys

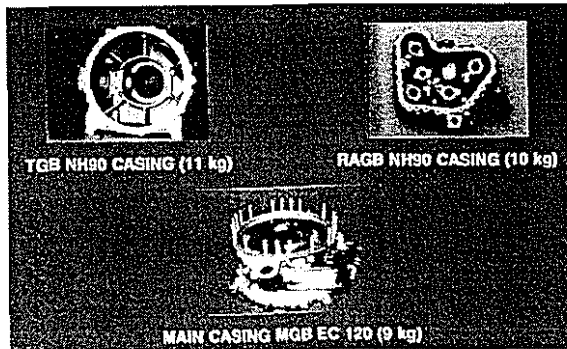

Figure 8 : Example of new WE43 Magnesium casings

### 2.3 Monitoring and fault detection means

In the event of a fault, it is essential both for the pilot in flight and for the maintenance personnel on the ground, to know the cause of the fault, the nature of the fault, and to quantify it in order to be able to control the situation.

- for the pilot : continue the flight, reduce power, divert, land ...
- for the ground maintenance personnel : monitor, limit the flights, remove the MGB for repair ...ant therefore optimise maintenance.

For each design, an inventory is drawn up of the potential failures which may occur in service through the fault analyses required by § 917 of the regulations, and this is combined with an appropriate monitoring means :

- spalling, scuffing... : magnetic plug,
- oil leak : pressure indicator, pressure alarm,
- wear : SOAP
- overheating : temperature measurement,
- fatigue crack : accelerometers.

These monitoring devices have been optimised over the last few years as well as the justification means, such as for example the efficiency testing of particle detection.

### 3. SOME SIGNIFICANT EXAMPLES

#### 3.1 Simplified maintenance : Interchangeability of spiral bevel gears

The spiral bevel gears in the gearboxes are shimmed in order to obtain running patterns under load which ensure correct operation. These running patterns are systematically checked by acceptance testing on a test bench or on aircraft, thus enabling any gears which are functionally unacceptable due to the dispersion of tolerances, to be "filtered" out.

The level of skill required to perform these operations considerably restricts the number of repair agencies approved for performing reconditioning or overhaul of gearboxes.

In order to simplify maintenance, the EC 120 gearboxes and the EC 135 TGB have been designed in such a way that they do not require shimming, and the gears are fully interchangeable : simplified architecture, controlled tolerances on the tooth geometry. Figure 9 shows the simplified assembly used for the EC 135 TGB. The running patterns under load are not checked, correct operation is guaranteed through compliance with the manufacturing tolerances for the parts.

The interchangeability demonstration was performed on the EC 135 TGB :

- the tolerances on the tooth geometry were determined through simulations under load,
- the geometries leading to the most penalising running patterns were produced on a pair of gears which was tested on a TGB on the test bench, to demonstrate that this "extreme" case would not jeopardise flight safety.

Currently, the EC 135 TGB gears are not shimmed and can be replaced by the customer without any requirement to check the running patterns under load after replacement : quality control is able to guarantee correct operation.

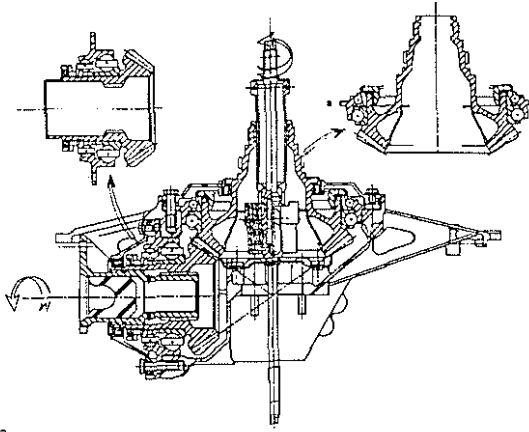

Figure 9 : Interchangeable TGB pinion : simplified assembly

### 3.2 Improved performance : Results of Tiger MGB qualification tests

The Tiger MGB, developed in the early 90's, incorporated new technologies and benefited from new design and optimisation techniques.

- use of CAD and simulation and calculation software : gears, modelling of casing deformations, FEM,
- maximised integration of functions,
- independent lubrication systems,
- modern materials and treatments : deep nitriding.

The techniques employed enabled the MGB to be developed very rapidly and the qualification testing was therefore able to begin relatively early in the Tiger development programme.

Confident of the MGB performance, and with a view to reducing the costs and development times, it was decided to use a single gearbox in order to perform the qualification of the MGB :

- 30 h preliminary endurance testing on the test bench using the load spectrum specified under FAR § 29.923,
- approximately 220 h FAA endurance (according to § 29.923) ground testing on the aircraft, using the same MGB.
- followed by 10 h operation at minimum oil pressure and maximum oil temperature,
- then additional testing as specified in § 29.927 covering torque overload and overspeed.

On completion of this first phase of testing, the strip-down demonstrated very satisfactory

behaviour of the MGB. In fact no abnormal wear or particular anomaly was found.

This gearbox was then re-assembled using the same components to continue qualification testing :

- 200 h endurance testing on the test bench using NATO 0-148 oil and the same loading spectrum.

The results achieved demonstrated the correct operation of the MGB despite the use of this very low viscosity oil, which is employed for cold climatic conditions.

After re-assembly, the tests were resumed :

- 300 h "reliability" testing on the test bench (same loading spectrum).

The strip-down of the MGB, which had then accumulated 760 hours of endurance testing under a spectrum considered as severe, confirmed the exceptional behaviour of the gearbox.

The MGB was then re-assembled for its last test :

- fatigue testing on the test bench at 140 % of the maximum load until failure of the parts.

In parallel with this testing campaign, an operating test after total loss of lubricant was performed on a MGB on the test bench.

The test demonstrated 1 hour 6 minutes operation after total loss of lubricant, from the time of ignition of the oil pressure alarm at the minimum flight power rating (level flight at 40 %  $V_{NE}$ ) with simulation of two vertical landings, one after 30 minutes, the other after one hour.

The test was stopped following failure of a bearing.

Apart from the failure of this bearing, the strip-down after the test showed the very good general condition of the MGB. The results of these tests demonstrated that the technical solutions adopted were able to provide a high level of performance and therefore to satisfy the very stringent requirements for the Tiger.

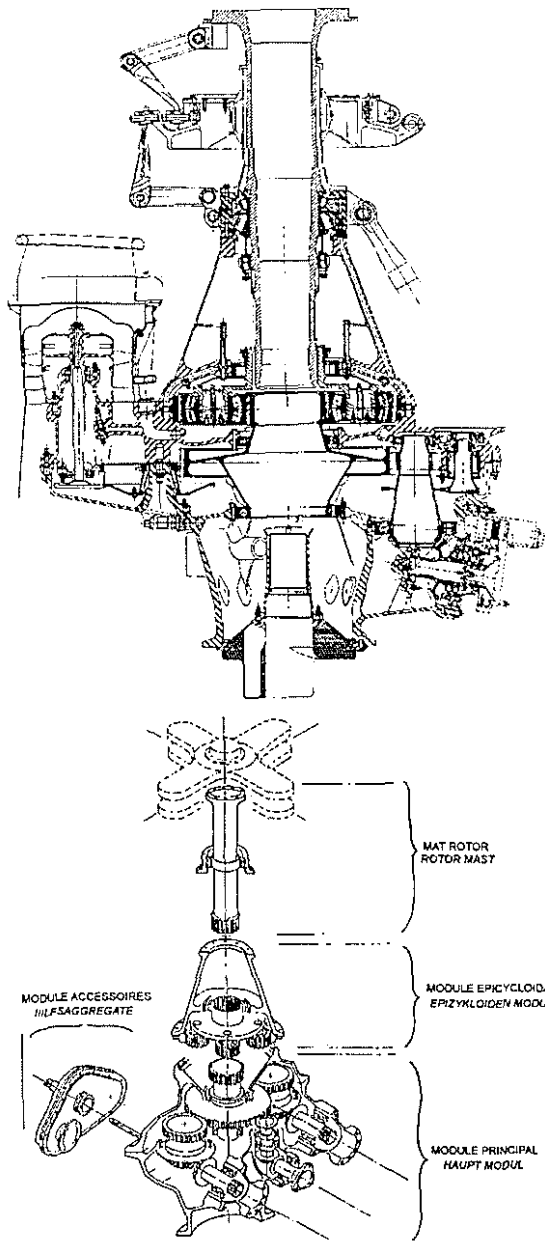

Figure 10 : Tiger Main Gearbox

### 3.3 Reduced maintenance costs : Modular MGB

The modular design with a diagnostics system for each module is an efficient means of satisfying this type of requirement.

In fact there is a choice to be made between the "fully integrated" type of design, where a single assembly results in optimum weight, but which leads to maintenance problems when a failure occurs, and the modular type of design for which it is possible to replace the faulty module without affecting the rest of the MGB.

The latter choice generally results in a higher weight, but provides maintenance cost benefits.

The solution adopted for the Tiger MGB is in fact a compromise between the two solutions, in other words it is a MGB which incorporates large interchangeable modules :

- rotor mast module,
- epicyclic module,
- main module,
- accessories module

As shown in Figure 11, the various Tiger MGB modules incorporate their own health diagnostic devices, which are designed such that any damage to one module, does not affect the adjacent modules.

Particle traps are used to avoid having to recondition all the modules when particles have been detected in a single damaged module.

The faulty module can be replaced by a spare module, thus providing a significant reduction in maintenance costs.

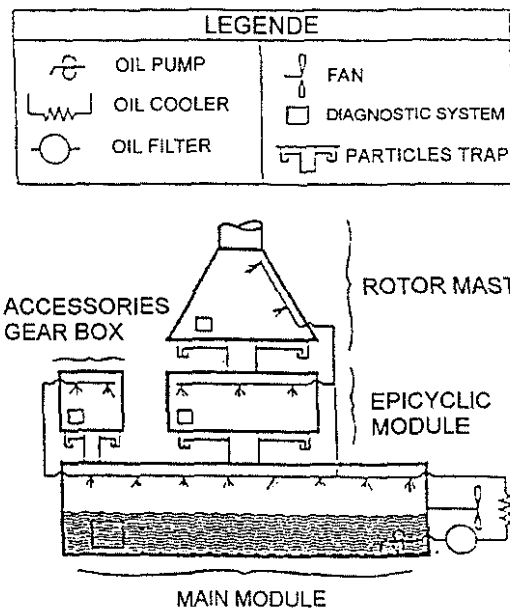

Figure 11 : Main Gearbox modular design

Tests have been conducted to demonstrate the efficiency of particle detection by magnetic plugs on each module, and the non contamination of one module by another.

These tests were performed by injecting particles into the MGB at various locations.

With the MGB operating, the time was recorded for the particles to reach the particle detectors and be detected. The detection was indicated in this case by an alarm.

Each module was tested independently to demonstrate that one module would not contaminate the others.

### 3.4 Application to the Colibri MGB

The Colibri MGB has benefited from all the new technologies developed and optimised over the last decade.

The means of simulation in particular enabled the development to be performed very rapidly, without any need to correct the tooth running patterns, their having been previously optimised through numerical simulations :

- 1st flight took place only 2 months after the assembly of the 1st gearbox,
- the development lead time was reduced to 12 months,
- certification testing was completed a mere 18 months after 1st flight.

As for the EC 135 TGB, the spiral bevel gear shimming has been deleted, and the gears have been designed to be fully interchangeable, therefore providing simplified maintenance.

Apart from the aspect of reduced development times and costs, EUROCOPTER have gone further and beyond the regulatory requirements by achieving for example one hour of operation after total loss of oil at the minimum flight power rating with two simulated landings, one after 30 minutes, the other after one hour, without any deterioration of the MGB in order to demonstrate the safety margins in the event of an oil leak.

Similarly, an efficiency test for particle detection by the magnetic plug has been conducted to show the reliability of the fault detection device employed.

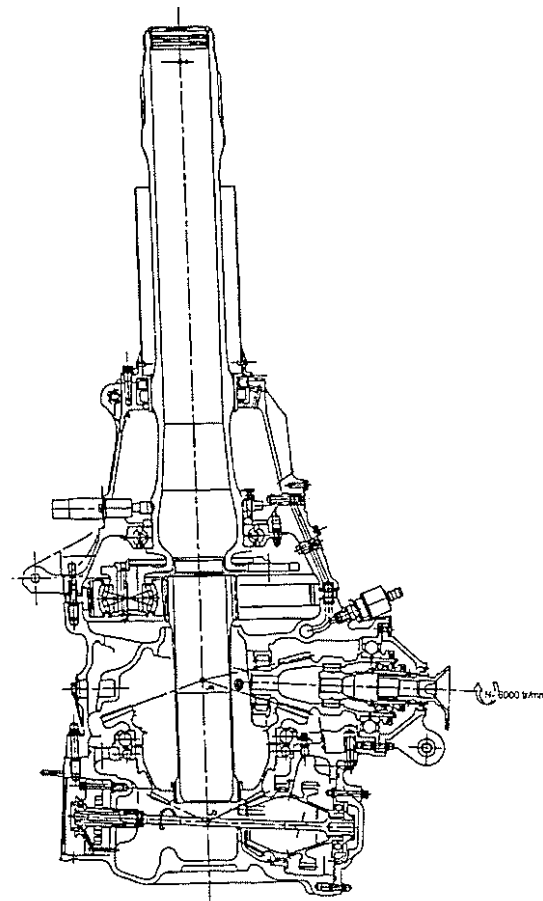

Figure 12 : Colibri Main Gearbox

## 4. CONCLUSION

In a difficult economic climate, EUROCOPTER have managed to develop and to apply new techniques in order to be able to satisfy the regulatory requirements as well as the market needs for the new generation helicopters.

The economic and regulatory requirements are in a perpetual state of change and EUROCOPTER are pursuing their efforts and continuing to develop new techniques in order to be ever more competitive in the field of main gearboxes.