

NINETEENTH EUROPEAN ROTORCRAFT FORUM

Paper n° M2

**TOOTH CONTACT PATTERN DEVELOPMENT BY
COMPUTATION FOR HELICOPTER GEARBOXES**

by

**Christine PIETTE
Transmissions and Gearboxes Engineer
EUROCOPTER FRANCE**

**September 14-16, 1993
CERNOBBIO (Como)
ITALY**

**ASSOCIAZIONE INDUSTRIE AEROSPAZIALI
ASSOCIAZIONE ITALIANA DI AERONAUTICA ED ASTRONAUTICA**

TOOTH CONTACT PATTERN DEVELOPMENT BY COMPUTATION FOR HELICOPTER GEARBOXES

By Christine PIETTE
Transmissions and Gearboxes Engineer
EUROCOPTER FRANCE

1- INTRODUCTION

The main objective of helicopter manufacturers consists in improving technical performances and safety while reducing manufacturing cycles and costs.

The cost analysis for a helicopter shows that one of the prevailing components is the Main Gearbox (MGB). When refining the analysis within the MGB, the longest development work hence the most costly phase is the development of the tooth contact patterns. In fact, this optimizing effort involves a large number of parameters and is dependent on the global deformation of the main gearbox casings.

Within the framework of the Franco-German TIGER programme, ambitious goals have been assigned such as the achievement of high reliability level, low vulnerability, and above all, a very short time from the initiation of engineering studies to the first prototype flight.

Considering these constraints, Eurocopter France has set up an original approach to the development of tooth contact patterns, by creating software packages which simulate the meshing functions and the behaviour of reduction gearboxes under load.

These enhancements were first introduced with the TIGER programme.

2- TIGER'S MAIN GEARBOX

The control linkage of the TIGER main gearbox (MGB) is comprised of three stages which ensure rotational speed reduction and power transmission between the engines and the main rotor (Figure 1).

- the 1st stage is a spiral-bevel pair which ensures the change in movement direction (horizontal to vertical)
- the 2nd stage (helical cylindrical toothing) sums up the power from the two engines
- the output stage (main rotor) consists of an epicyclic gear train, with a fixed ring gear (spur cylindrical toothing).

The tail rotor drive function is ensured through two stages, one with cylindrical toothing, the other with spiral-bevel toothing (see Figure 1).

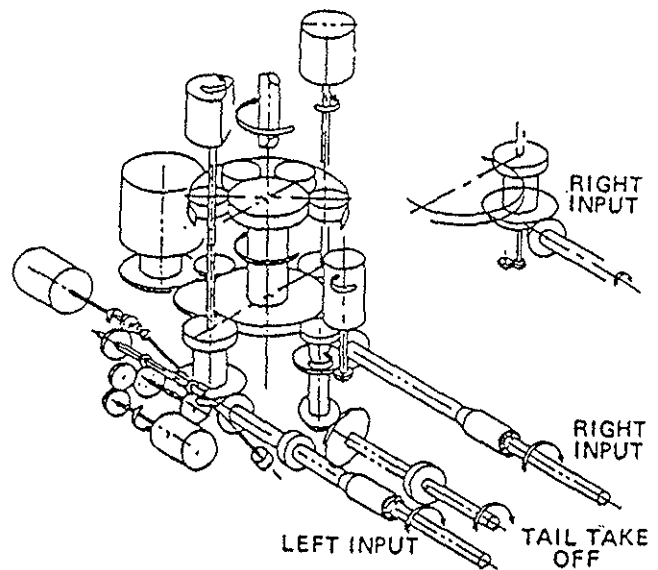

FIGURE 1: Control linkage of the TIGER Main Gearbox

3/ TOOTH CONTACT PATTERN DEVELOPMENT

3.1/ Principle

The main gearbox casing deformation under the effect of the torque causes relative displacements between the gears (see figure 2), and particularly at the meshing points ; these displacements result in local overloads and a poor meshing continuity. To ensure proper operation of the reduction gearbox, enhance its reliability, and reduce its weight, it is necessary to perform corrections on tooth contact patterns (grinding of tooth flanks) to account for these deformations under load.

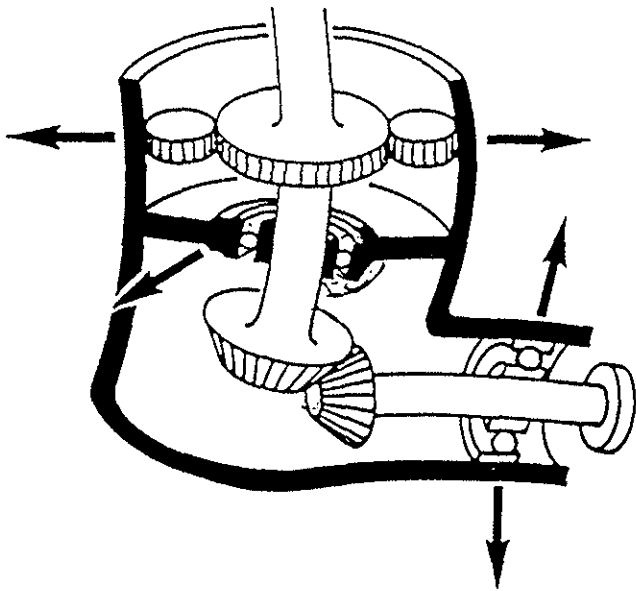

FIGURE 2: A Main Gearbox Under Load

3.2/ Conventional method

In the case of spiral-bevel teeth for which the development of tooth contact patterns is a particularly tricky operation, the first step consists in dimensioning the pinion and gear pair by means of the Gleason software programme. Then, the stability of the tooth contact pattern at no load and its location on the surface of the tooth are adjusted by means of the TCA (Tooth Contact Analysis) software programme. The "summary" (summary of adjustments for the grinding machines) is then transmitted to the Production Department for the grinding of the pairs.

The development of tooth contact patterns is carried out on test bench, with real main gearboxes. The handling consists in analyzing the patterns after torque loading and performing the successive corrective machining operations on the tooth flanks until satisfactory tooth contact pattern is achieved (see Figure 3).

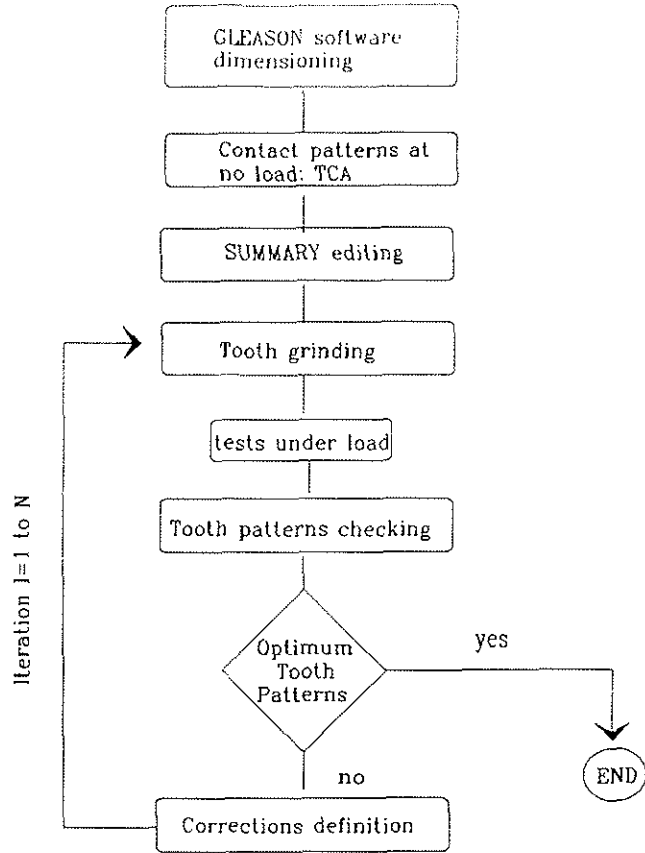

FIGURE 3: The conventional method for the tooth contact pattern development

This experimental method is time-consuming and costly in terms of installation, test, removal, grinding and checking cycle. In addition, it must necessarily be integrated at an early stage in manufacturing, which is very costly due to the number of parts used.

For information, such a development work for a TIGER-type MGB requires 8 to 15 iterations to obtain optimized contact patterns.

3.3/ The method selected for the TIGER main gearbox

Considering the very short time available for development of the first TIGER prototype, a conventional tooth contact pattern development could not be envisaged before the first flight.

The original approach selected for the TIGER consisted in defining, by calculation, before the manufacturing of the parts, the first corrections to be implemented on the tooth surfaces to obtain correct tooth contact pattern under load, taking into account the deformations of main gearbox casing and tolerances of the various mechanical items.

Firstly, the spiral bevel teeth are dimensioned as in the conventional method, with the Gleason, then the TCA software programme for tooth contact patterns at no load (see Figure 4).

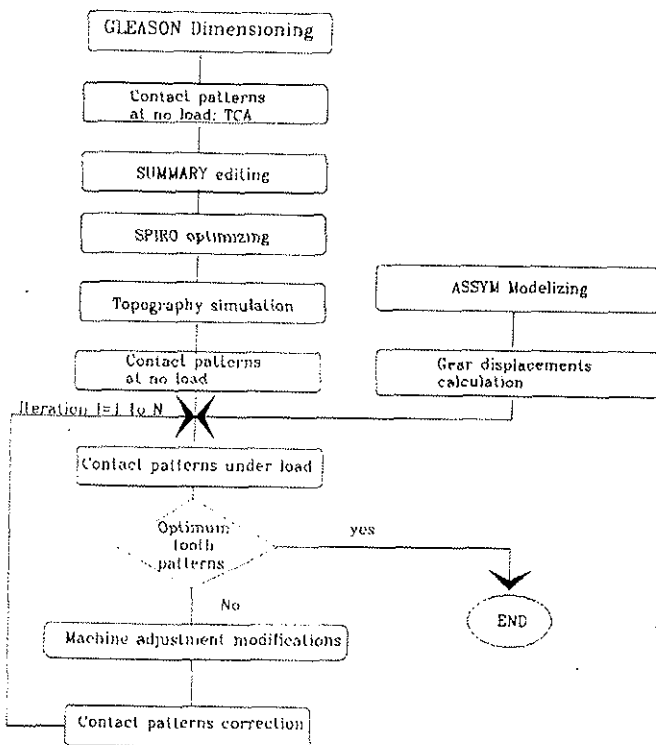

FIGURE 4: The new method for the tooth contact pattern development

Then, the calculation of displacements at meshing points was performed, based on a finite element model of a complete MGB: casings, gears, and bearings.

This work was performed by means of the ASSYM software programme ("Analyse et Simulation des SYstèmes Mécaniques" i.e "Mechanical system simulation analysis").

Simultaneously with this MGB behaviour simulation work, the spiral-bevel teeth were modeled by means of the SPIRO software (SPIRO-bevel tooth optimizing software), similarly cylindrical toothings were modeled on PRINCE software ("PRogramme INteractif de Calcul des Engrenages cylindriques", i.e "Cylindrical interactive calculation programme").

The meshing was first simulated at no load, then the contact patterns under load were calculated after introducing displacements.

For spiral-bevel gears, the contact pattern modifications under load were performed based on grinding parameters: pressure angle, mounting clearance, machine adjustment, etc.

The grinding machine adjustment parameters which permit optimized contact pattern were determined by successive simulations, using the SPIRO software programme.

Similarly, for cylindrical gears, the PRINCE software programme enabled the calculation of corrections on profile and helix, to obtain satisfactory tooth contact patterns under load.

Simulations of contact patterns under load introducing the tolerances of mechanical items were then carried out in order to check the stability of contact patterns.

Therefore, as early as the first manufacturing of the gears, the tooth surface correction parameters were integrated ; moreover, taking the tolerances for adjustment of gear sensitivity (i.e. stability) into account especially allowed to free from those shims generally used for adjusting the spiral-bevel gears.

4/ MGB MODELLING ON ASSYM SOFTWARE

It should be reminded that the deformation of the MGB casing under torque generates relative displacements between gears and that a contact pattern under load on a gear results from the meshing kinematics with the gear axis displacement added.

That is why one of the prevailing stages in the development of contact patterns is to determine the displacements of gear axes under load.

Based on the principle of finite elements adapted to mechanics, the ASSYM software programme is a powerful tool which simulates the global behaviour of a mechanical assembly. It also calculates the displacement at all points in this assembly.

Specific elements adapted to the design process of the mechanical system were developed in the ASSYM software to modelize clearances, bearings, gears and casings.

So, the TIGER MGB model is comprised of the casing, the gears and the bearings. The difficulty in the work consists in simplifying the system, such as the TIGER MGB (see casing on Figure 5), to turn it into a representative 2 or 3D model.

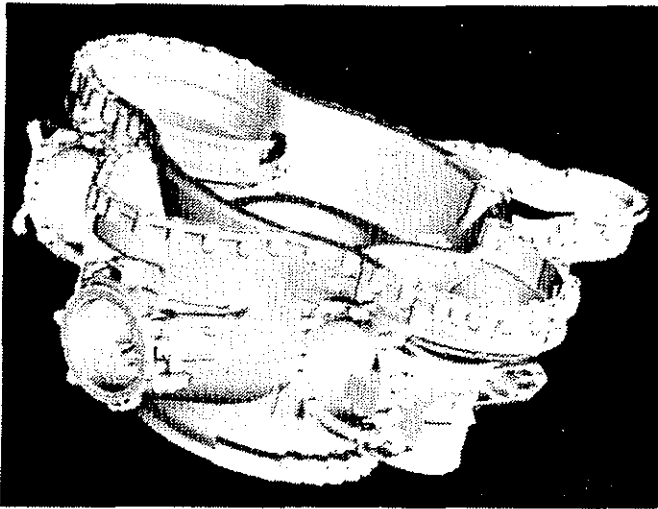

FIGURE 5: TIGER MGB's Casing

Moreover, a precise analysis of the various connections between the components of the model must be conducted with a view to introducing the proper conditions at the boundaries.

The calculation carried out on the TIGER helicopter revealed rather significant displacements under load. For reference, here are a few significant values:
 MGB rotation from the left to the right, in the order of 30° at input level,
 pivoting of the right-hand and left-hand vertical gear wheels, in the order of 15°.

Based on absolute displacements, the relative displacements of a pinion with respect to the meshing gear are calculated in terms of offset (distance between axes), variation of the angle

between the pinion and gear axes, and axial displacements of the pinion and the gear (see Figure 6).

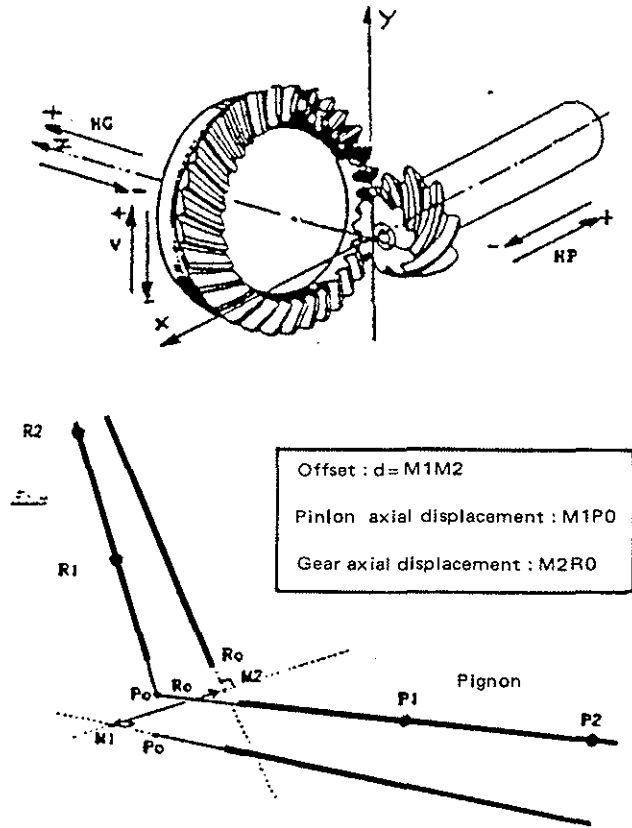

FIGURE 6: Displacements between pinion and gear

5/ MODELLING USING SPIRO AND PRINCE SOFTWARES

The SPIRO software simulates the control linkage of the Gleason grinding machines. The first operation consists in defining the adjustments required to dress the grinding wheel; the profile of the grinding wheel is then calculated, and the profile of the teeth is generated. Once the O.B. profile (profile generated by the outer face of the wheel) and the I.B. profile (profile generated by the inner face of the wheel) are defined, the teeth surfaces are calculated.

The meshing of the teeth is then performed (see Figure 7); the element used is a 3D hexaedral element comprising 20 nodes.

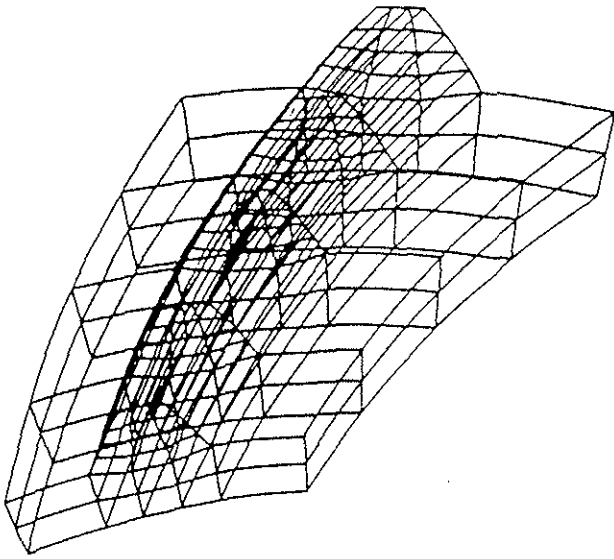

FIGURE 7: An example of tooth meshing

Calculation by finite element method in 3D mode is used to determine the stiffness matrix. For this calculation, the boundary conditions must be imposed.

Figure 8 illustrates the boundary conditions selected for the TIGER helicopter input wheel. In this case, two meshing lines are sunk in (the three degrees of freedom in translation are cancelled) in order to simulate the material on either side of the tooth; a face is sunk in at mid-width, to simulate the wheel web.

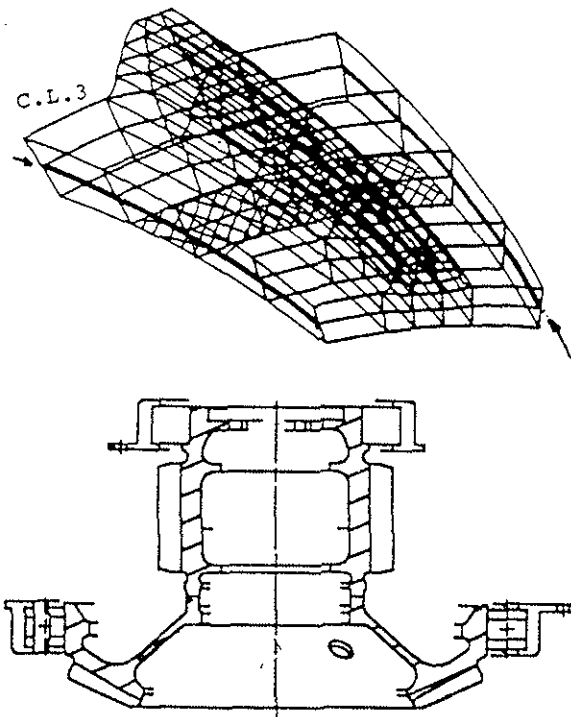

FIGURE 8: Boundary conditions selected for the TIGER input wheel

Then, the percentage of the load transmitted by each couple of teeth (5 consecutive couples are studied) as a function of the meshing position is calculated.

The last calculation concerns contact patterns under load, the input parameters being the gear displacements calculated by the ASSYM software.

A view of the contact pattern under load, with the various Hertz pressures on the active flanks highlighted, can then be created.

The topographic surfaces to be obtained on tooth flanks are then transmitted to the Production Department, via the computer network.

An example of tooth software corrections is given in figure 9. In this case, an excess material thickness of 20 microns is required on one side of the tooth.

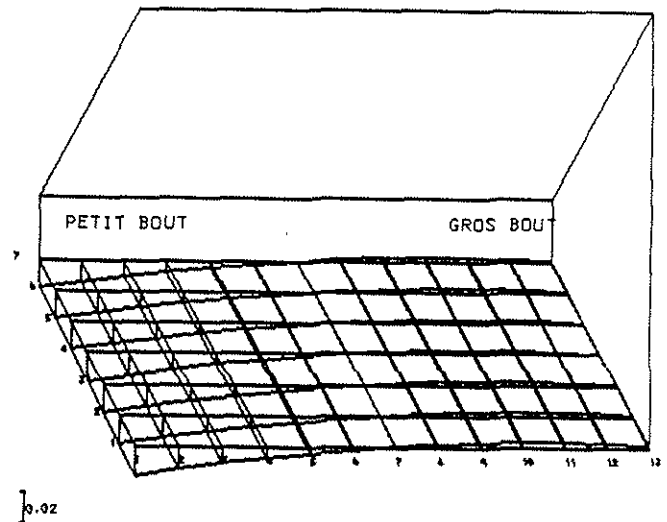

FIGURE 9: Tooth software corrections

A complementary module in the SPIRO software, so-called SPIRO-MO ("SPIRO Machine Outil", i.e. "Machine tool spiro") permits the proper control of the surfaces generated by the Production department, on spiral-bevel gears.

In fact, a first grinding operation on tooth surfaces is performed by means of the data supplied by the Engineering Department (topographic surfaces and corresponding machine adjustments).

The deviations between the surfaces obtained and the desired surfaces (deviations caused by the machine clearances, amongst others) are then measured by means of a 3D machine (Zeiss-type).

The SPIRO-MO module then permits the recalculation of the grinding machine adjustments, in order to cancel the deviations. Therefore, high reliability results are obtained (final surfaces obtained to within 2 to 3 microns).

The same path is followed for cylindrical teeth, with the PRINCE software programme.

The specific feature of this software programme is to use the finite prisms method : the 3-D problem is reduced to a 2-D problem (the third dimension which here represents the tooth facewidth is modeled using a continuously derivable serie).

All calculation steps previously quoted for the SPIRO software are used in PRINCE software. Compared with the SPIRO software, the difference lies at the level of the data transmitted to the Production Department ; for cylindrical gears, these data do not concern topographic surfaces but corrections according to the profile and the helix.

6/ WHAT IS SOUGHT ?

Firstly, a tooth contact pattern under load comprised within the surface of the tooth and spread as widely as possible, is sought. Maximum surface utilization is desired.

Then, the Hertz pressure values are analyzed: the objective is to obtain the lowest possible values, and as consistent as possible.

Finally, the sliding speeds are also checked, to avoid scratches in operation.

The optimization of all parameters is carried out by means of modifications to the tooth topography (tooth surface), as regards spiral-bevel gears, and by means of modifications to the helix and profile for cylindrical teeth.

7/ RESULTS

7.1/ Problems encountered

The major problem encountered in this calculation approach was the MGB modelling by means of the ASSYM software.

Since the calculated displacement values (using ASSYM) directly impact on the calculation of tooth bearing patterns by means of SPIRO and PRINCE softwares , it is mandatory to create as representative a model as possible.

Considering the geometric complexity of the TIGER MGB casing and the lack of experience,

the modelling work was tedious and time-consuming; 4 months were necessary for adjusting the model ...

7.2/ Tooth contact patterns simulation

Tooth contact patterns simulated under load and those observed after the first bench test are quite similar (see Figure 10). A slight difference as regards the spreading of the pattern is found. This difference is due to the fact that tooth contact pattern simulation under load is a succession of static contact patterns (quasi-static model) for a given power P, whereas the real tooth contact pattern is a dynamic pattern, i.e. the envelope of all contact patterns from zero power to power P.

It should be noted that one of the most significant improvement achieved is the simulation of the effect of tolerances on the change in contact patterns : the possible differences in the contact patterns between two MGBs are simulated, which therefore prevents any additional adjustments.

The tooth contact patterns obtained during the first test proved satisfactory to perform prototype flights.

Final optimizing is effected further on test bench. In consideration of tooth contact patterns obtained, the expert engineer defines the ultimate corrections by means of the SPIRO-MO software.

Pinion tooth contact pattern

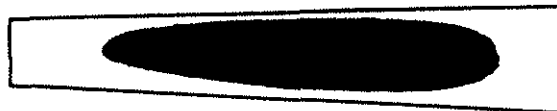

TOOTH CONTACT PATTERN OBTAINED ON BENCH TEST

Pinion tooth contact pattern



TOOTH CONTACT PATTERN CALCULATED

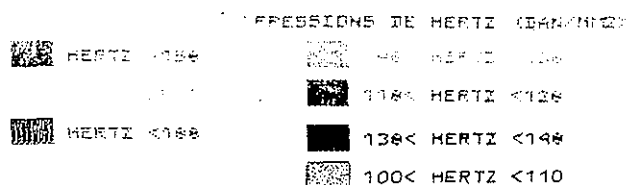

FIGURE 10:

8/ CONCLUSION

The approach implemented enables 80 to 90 % approximation of the optimum solution : small deviations were introduced by calculation using the ASSYM software. It is now necessary to acquire experience on this type of calculation and to control influences of modelling accuracy on the results.

Similar approaches on other MGBs will be conducted to enrich the experience acquired on this type of calculation and will even better promote optimum tooth contact pattern achievement.

Nevertheless, the quality of tooth contact patterns obtained from the first run is satisfactory to perform the TIGER prototype flights which could have never been achieved with the conventional tooth development method.

The time saved for the manufacturing cycle was significant : 28 months; the production cost savings were in the order of 2 million French Francs.

Moreover, these softwares enlarge the engineer's possibilities to anticipate the effect of mechanical tolerances and manufacturing control.

Finally, all three softwares (ASSYM, SPIRO and PRINCE) prove to be invaluable analysis supports for understanding those problems encountered on MGBs during flights or tests ; as a matter of fact, through a modelization and a calculation that simulate the behaviour of an MGB under load, the engineer can better analyze and understand the phenomena.

REFERENCES:

1- M.Vialle "Tiger MGB: high reliability low weight " 47th Annual Forum Proceedings May 6-8 1991- Phoenix -Arizona

2- C.Piette and P.Maret " Etude du développement des portées de dentures par calcul" 3rd World Congress on gearing and power transmissions- 12-14 february 1992- Paris- France